

ECHO®

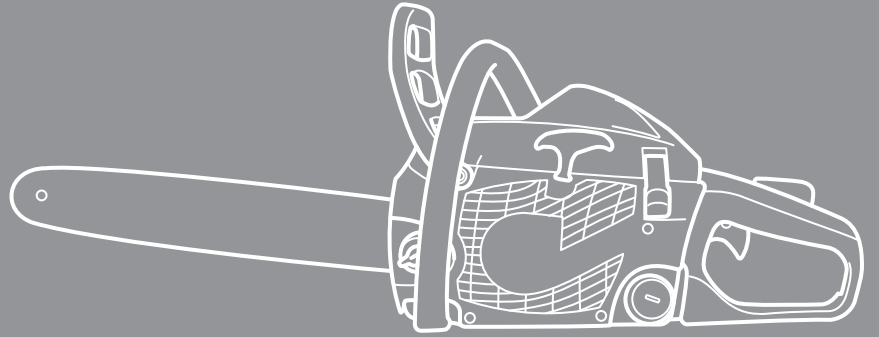

SERVICE MANUAL

CS-310ES



Ord. No. 401-34

INTRODUCTION

This service manual contains information for service and maintenance of **ECHO CHAIN SAW**, model **CS-310ES**.

For systematic diagnosis, to avoid extra work, time loss and to meet Emission regulation, please refer to “Troubleshooting guide” that describes problems, testing, remedies and references. We recommend you make use of Operator’s Manual and Parts Catalogue together with this manual when servicing.

We are constantly working on technical improvement of our products. For this reason, technical data, equipment and design are subject to change without notice. All specifications, illustrations and directions in this manual are based on the latest product information available at the time of publication.

	Page		Page
1 SERVICE INFORMATION	2	5 CLUTCH SYSTEM	38
1-1 Specifications	2	5-1 Inspecting clutch parts.....	39
1-2 Technical data	3	5-2 Replacing clutch parts	40
1-3 Torque limits	4	5-3 Installing clutch assembly.....	40
1-4 Special repairing materials.....	4		
1-5 Service Limits	5	6 CHAIN BRAKE SYSTEM	42
1-6 Special tools	6	6-1 Disassembling chain brake	43
		6-2 Assembling brake parts.....	44
2 STARTER SYSTEM	7		
2-1 Disassembling starter assembly.....	8	7 SAW CHAIN LUBRICATION SYSTEM	45
2-2 Replacing starter rope	9	7-1 Inspecting oil cap and strainer.....	45
2-3 Assembling starter.....	10	7-2 Inspecting oil tank vent.....	46
2-4 Replacing starter pawl.....	12	7-3 Inspecting oil line.....	47
		7-4 Replacing oil line and grommet.....	48
3 IGNITION SYSTEM	13	7-5 Replacing auto-oiler assembly	49
3-1 Troubleshooting guide.....	14		
3-2 Testing spark	15	8 ENGINE	51
3-3 Inspecting spark plug	15	8-1 Testing cylinder compression	52
3-4 Inspecting ignition switch.....	16	8-2 Cleaning cooling air passages	52
3-5 Replacing ignition switch.....	17	8-3 Inspecting muffler and exhaust port	53
3-6 Inspecting ignition coil resistance.....	18	8-4 Testing crankcase and cylinder seal.....	54
3-7 Replacing spark plug cap and coil.....	19	8-5 Removing engine block	55
3-8 Replacing ignition coil.....	19	8-6 Inspecting cylinder.....	56
3-9 Setting pole shoe air gaps.....	20	8-7 Inspecting piston and piston ring.....	57
3-10 Inspecting flywheel and key	20	8-8 Inspecting crankcase and crankshaft.....	57
		8-9 Replacing oil seal and ball bearing.....	58
4 FUEL SYSTEM	22	8-10 Installing piston and piston ring.....	59
4-1 Inspecting air filter	23	8-11 Assembling piston into cylinder.....	60
4-2 Inspecting fuel cap and fuel strainer.....	23	8-12 Installing engine block.....	61
4-3 Inspecting fuel tank and line.....	24		
4-4 Inspecting and replacing tank vent.....	25	9 REAR HANDLE AND CONTROL SYSTEM	62
4-5 Replacing purge bulb	27	9-1 Replacing throttle trigger	62
4-6 Replacing fuel line and fuel return line	28	9-2 Replacing cushions	64
4-7 Adjusting carburetor	29		
4-7-1 General adjusting rules	29	10 GUIDE BAR MOUNTING SYSTEM	65
4-7-2 Presetting idle adjust screw, L mixture needle and H mixture needle	29	10-1 Replacing chain tensioner	66
4-7-3 Adjusting carburetor	31	10-2 Replacing guide bar stud.....	67
4-8 Winter plug	32		
4-9 Testing carburetor.....	33	11 MAINTENANCE GUIDE	68
4-10 Inspecting crankcase pulse passage	34	11-1 Troubleshooting guide.....	68
4-11 Inspecting metering lever height	34	11-2 Disassembly Chart	70
4-12 Inspecting inlet needle valve	35	11-3 Service Intervals.....	71
4-13 Inspecting diaphragm	36		
4-14 Replacing Welch plug.....	36	INDEX	72
4-15 Installing carburetor.....	37		

1 SERVICE INFORMATION

1-1 Specifications

Model		CS-310ES	
Dimensions	Length*	mm(in)	396 (15.59)
	Width	mm(in)	232 (9.13)
	Height	mm(in)	268 (10.55)
Dry weight*		kg(lb)	4.0 (8.8)
Engine	Type	KIORITZ, air-cooled, two-stroke, single cylinder	
	Rotation	Clockwise as viewed from the output end	
	Displacement	cm ³ (in ³)	30.5 (1.861)
	Bore	mm(in)	36.0 (1.417)
	Stroke	mm(in)	30.0 (1.181)
	Compression ratio		6.7
Carburettor	Type	Diaphragm horizontal-draught with auto-return choke	
	Model	Walbro WT-946	
	Venturi size-Throttle bore	mm(in)	11.11 - 14.3 (0.437 - 0.562)
Ignition	Type	CDI (Capacitor discharge ignition) system Digital magneto	
	Spark plug	BPMP8Y	
Starter	Type	ES(effortless-start)	
	Rope diameter x length	mm(in)	3.0 x 920 (0.12 x 36.2)
Fuel	Type	Premixed two-stroke fuel	
	Mixture ratio	50 : 1 (2 %)	
	Petrol	Minimum 89 octane petrol	
	Two-stroke air cooled engine oil	ISO-L-EGD (ISO/CD13738), JASO FC/FD	
	Tank capacity	L (U.S.fl.oz.)	0.25 (8.5)
Exhaust	Muffler type	Spark arrester muffler with catalyst	
Clutch	Type	Centrifugal, 3-shoe slide with 3-tension spring	
Guide bar / Saw chain lubrication type		Automatic	
Oil	Tank capacity	L (U.S.fl.oz.)	0.26 (8.8)
Sprocket	Type	Spur	
	Number of teeth	6	
	Pitch	in	3/8

* Without guide bar and saw chain.

Cutting devices						
Guide bar	Type	30RC43S-3/8	30RC50M-3/8	35RC43S-3/8	35RC50M-3/8	
	Called length	cm	30		35	
	Gauge	in	0.043, 0.050			
Saw chain	Type	CARLTON N1C-BL	OREGON 91VX / 91VG / 90SG			
	Number of drive links	45	47	52	53	
	Pitch	in	3/8			
	Gauge	in	0.043, 0.050			

1-2 Technical data

Engine			
Idling speed	r/min		3,200 +/- 400
Wide open throttle speed*	r/min		12,000 - 13,000
Clutch engagement speed	r/min		4,000 - 4,500
Compression pressure	MPa (kgf/cm ²) (psi)		0.88 (9.0) (128)
Ignition system			
Spark plug gap	mm(in)		0.6 - 0.7 (0.024 - 0.028)
Minimum secondary voltage at 1500 r/min	kV		15.0
Primary coil resistance	Ω		140 - 180
Secondary coil resistance	kΩ		1.9 - 2.3
Pole shoe air gaps	mm(in)		0.3 - 0.4 (0.012 - 0.016)
Ignition timing	at 1,000 r/min	°BTDC	14
	at 3,000 r/min	°BTDC	12
	at 8,000 r/min	°BTDC	33
	at 10,000 r/min	°BTDC	35
	at 12,000 r/min	°BTDC	33
Carburettor			
Idle adjust screw initial setting	turns in**		7/8
L mixture needle initial setting	turns back		2 1/2
H mixture needle initial setting	turns back		2 1/4
Test Pressure, minimum	MPa (kgf/cm ²) (psi)		0.05 (0.5) (7.0)
Metering lever height	mm(in)		1.65 (0.06) lower than diaphragm seat
Chain oil discharge volume at 7000 r/min	mL/min(U.S.fl.oz./min)		Fixed 7 mL/min

BTDC: Before top dead centre.

* With 30/35 cm guide bar and properly adjusted saw chain.

**Set idle adjust screw to the point that its tip contacts throttle plate before initial setting.

1-3 Torque limits

Descriptions		Size	kgf·cm	N·m	in·lbf
Starter system	Starter pawl	M5*	30 - 45	3 - 4.5	26 - 40
	Starter case	M5**	35 - 50	3.5 - 5	30 - 45
Ignition system	Magneto rotor (Flywheel)	M8	250 - 290	25 - 29	220 - 255
	Ignition coil	M5*	30 - 45	3 - 4.5	26 - 40
	Ignition switch	M10	15 - 30	1.5 - 3	13 - 26
	Spark plug	M14	130 - 170	13 - 17	110 - 150
Fuel system	Carburettor	M5**	35 - 50	3.5 - 5	30 - 45
		M5**	30 - 45	3 - 4.5	26 - 40
Clutch	Clutch hub	LM10	230 - 260	23 - 26	200 - 230
Engine	Crankcase	M5*	60 - 80	6 - 8	60 - 70
	Engine mount	M5**	70 - 110	7 - 11	60 - 95
	Muffler	M5	70 - 90	7 - 9	60 - 80
	Intake insulator	M5	50 - 70	5 - 7	45 - 60
Others	Front handle	M5**	30 - 50	3 - 5	26 - 45
	Rear handle assembly	M5**	30 - 50	3 - 5	26 - 45
	Brake lever	M4	25 - 35	2.5 - 3.5	22 - 30
	Sprocket guard	M4**	10 - 20	1 - 2	9 - 17
	Guide bar	M8	200 - 230	20 - 23	175 - 200
Regular bolt, nut and screw		M3	6 - 10	0.6 - 1	5 - 9
		M4	15 - 25	1.5 - 2.5	13 - 22
		M5	25 - 45	2.5 - 4.5	22 - 40
		M6	45 - 75	4.5 - 7.5	40 - 65

LM: Left-hand thread *Apply special repairing materials ** Tapping screw

1-4 Special repairing materials

Material	Location	Remarks
Adhesive	Ball bearing outer / crankcase	Loctite #675 or equivalent
	Stud bolt	
Liquid gasket	Crankcase seams	ThreeBond 1207D
Thread locking sealant	Starter pawl	Loctite #242, ThreeBond #1324 or equivalent
	Engine mount	
	Ignition coil	
Grease	Clutch needle bearing	Lithium based grease
	Starter centre shaft	
	Chain brake (metal contact part)	Molybdenum grease (approx.1 gram)

1-5 Service Limits

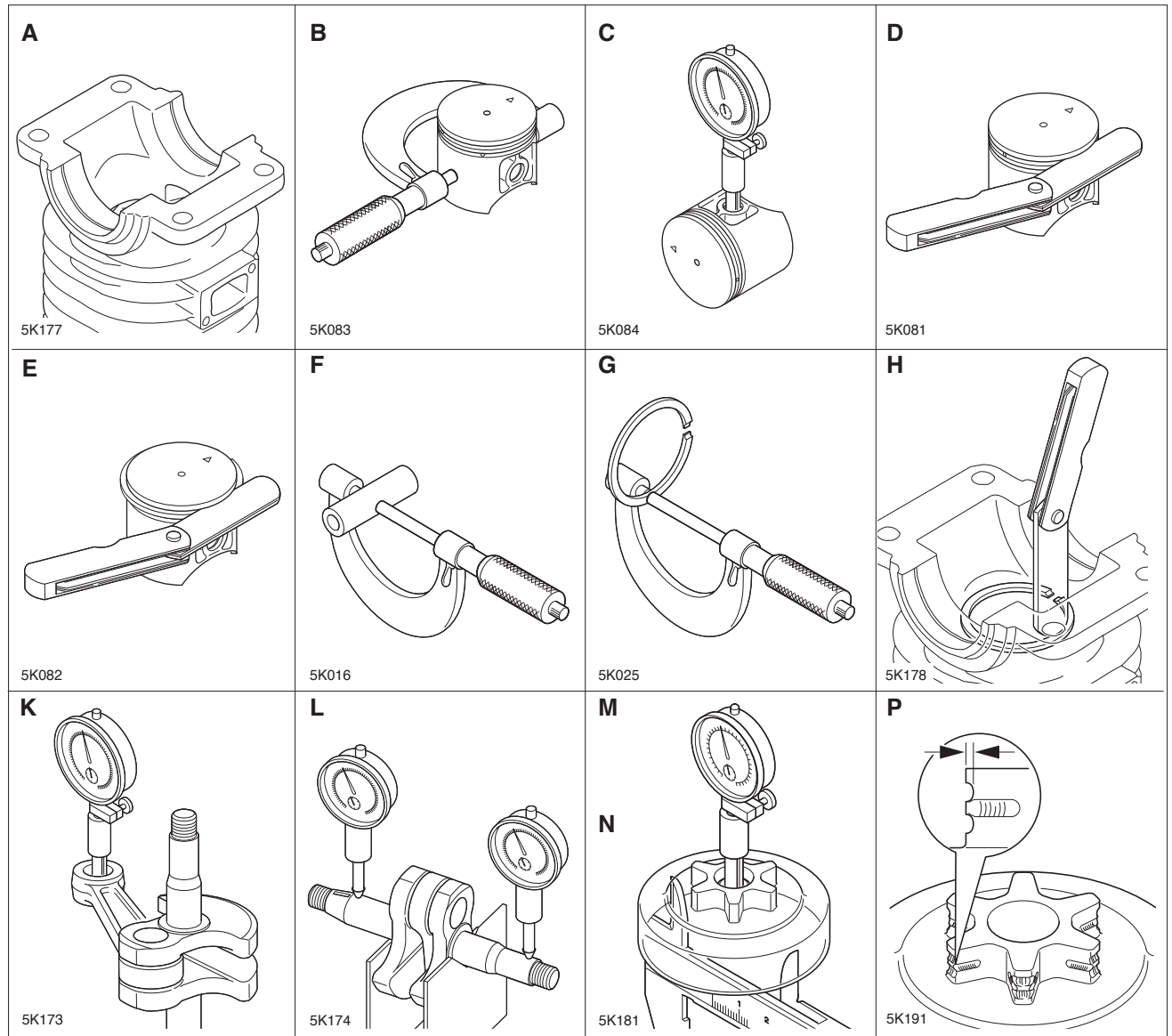

Description		mm (in)	
A	Cylinder bore	When plating is worn and aluminium can be seen	
B	Piston outer diameter	Min.	35.91 (1.414)
C	Piston pin bore	Max.	8.035 (0.3163)
D	Piston ring groove	Max.	1.5 (0.063)
E	Piston ring side clearance	Max.	0.1 (0.004)
F	Piston pin outer diameter	Min.	7.98 (0.3142)
G	Piston ring width	Min.	1.45 (0.057)
H	Piston ring end gap	Max.	0.5 (0.02)
K	Con-rod small end bore	Max.	12.000 (0.4724)
L	Crankshaft runout	Max.	0.01 (0.001)
M	Sprocket bore	Max.	10.80 (0.4252)
N	Clutch drum bore	Max.	61.5 (2.42)
P	Sprocket wear limit	Max.	0.5 (0.02)

1-6 Special tools

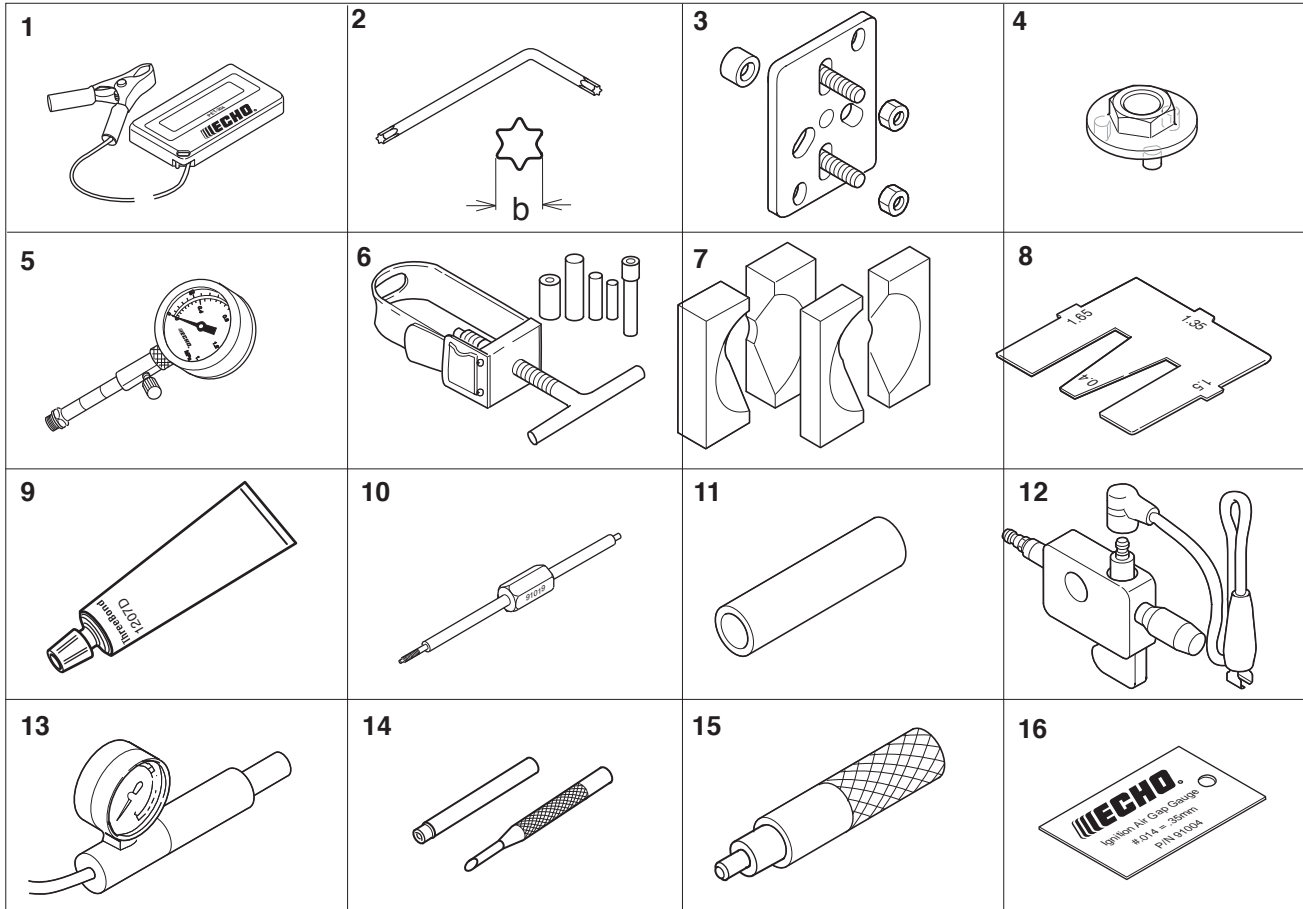

Key	Part Number	Description	Reference
1	G310-000050	Tachometer PET-304	Measuring engine speed to adjust carburettor
2	X605-000050	Torx L wrench	Removing and installing bolt
3	897501-03938	Puller	Removing magneto rotor
4	897505-16133	Clutch tool	Removing and assembling clutch assembly
5	91037	Compression gauge	Measuring cylinder compression
6	897702-30131	Piston pin tool	Removing and installing piston pin
7	897701-06030	Bearing wedge	Removing and crankshaft ball bearings
8	897563-19830	Metering lever gauge	Measuring metering lever height on carburettor
9	X686-000000	ThreeBond 1207D	Applying crankcase seam
10	91019	Limiter cap tool	Removing and installing limiter cap
11	897726-21430	Oil seal tool	Installing oil seals and clutch plate
12	897800-79931	Spark tester	Checking ignition system
13	897803-30133	Pressure tester	Testing carburettor and crankcase leakage
14	500-500	Welch plug tool	Removing and installing welch plug tool
15	X646-000030	Auto-oiler tool	Installing pencil type Auto-oiler
16	91004	Module air gap gauge	Adjusting pole shoe air gaps

2 STARTER SYSTEM (ES starter)

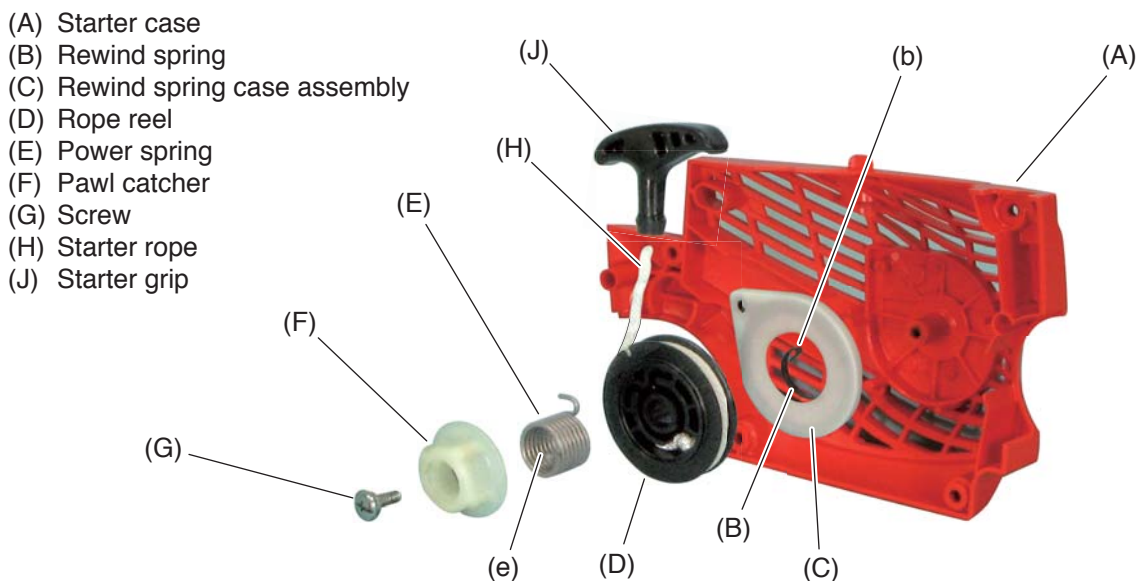
**Construction**

1. Rewind spring case assembly (C) is installed inside starter case (A).
2. Rope reel (D) with starter rope (H) is installed on rewind spring case assembly.
3. Hook located on the backside of rope reel engages with end (b) of rewind spring (B).
4. Power spring (E) is installed on rope reel.
5. Hook of power spring engages with rope reel and top end hook (e) of power spring engages with pawl catcher (F).

Working principle

1. When starter grip (J) is pulled, rope reel (D) rotates.
2. The rotation force of rope reel (D) is transmitted to pawl catcher (F) by power spring (E).
3. Pawl catcher (F) engages with starter pawls on flywheel to turn crankshaft.
4. The load from compression pressure in cylinder will keep crankshaft from rotating as power spring (E) is twisted and accumulates energy.
5. As starter grip is pulled further, more energy is stored in power spring (E) until accumulated energy is enough to overcome compression pressure in cylinder.
6. When accumulated energy in power spring (E) overcomes the load from compression pressure in cylinder, crankshaft is rotated.
7. Power spring absorbs compression resistance of cylinder and snatch back of engine during starting action.
8. When starter rope is released, rope reel (D) is returned together with power spring (E) and pawl catcher (F) by rewind spring tension.
9. After engine starts, starter pawls pivot outward by centrifugal force and disengage from pawl catcher (F).

2-1 Disassembling starter assembly



1. Remove sprocket guard (A).
2. Remove brake lever (B) and cylinder cover (C).



3. Remove three screws and remove starter assembly (D) from unit.



4. Pull out starter rope about 30 cm (12 in) and hold rope reel (E) by hand. Loop excess rope in rope reel notch (e) as shown.
5. Rotate rope reel (E) counterclockwise to release tension of rewind spring.

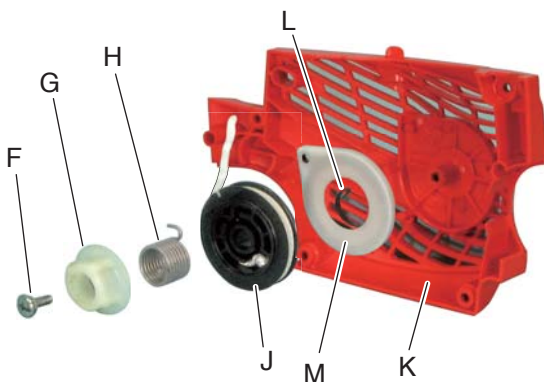

6. Remove screw (F).
7. Remove pawl catcher (G) and power spring (H).
8. Remove rope reel (J) from starter case (K) slowly to prevent rewind spring (L) from unwinding.
9. Remove rewind spring case assembly (M) from starter case (K).

WARNING  **DANGER**

Wear eye protection and take care when removing starter drum. Rewind spring may unwind suddenly and cause personal injury.

2-2 Replacing starter rope

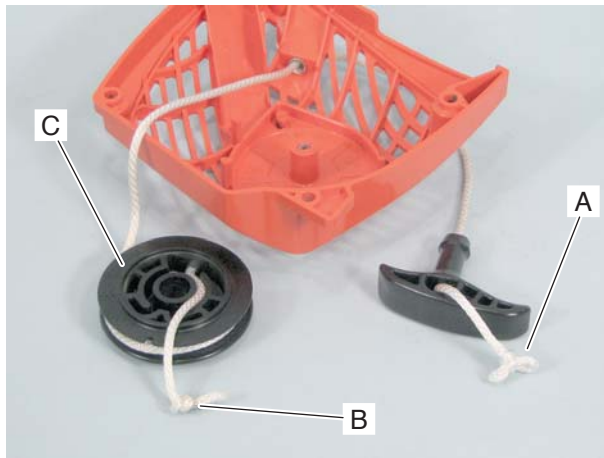

1. Pull out and untie knot (A).
2. Pull knot (B) to remove rope from rope reel (C).

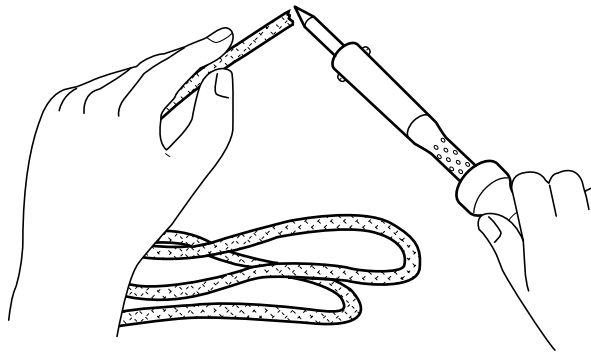

3. When installing a new starter rope, singe both ends of the rope to prevent fraying.

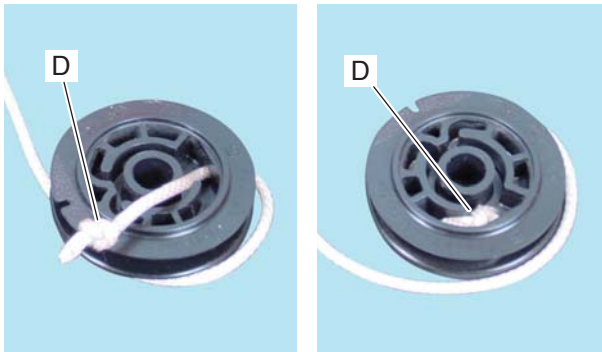

4. Make a knot (D) at end of starter rope and pass the rope through hole of rope reel, then press the knot (D) into recess as shown.

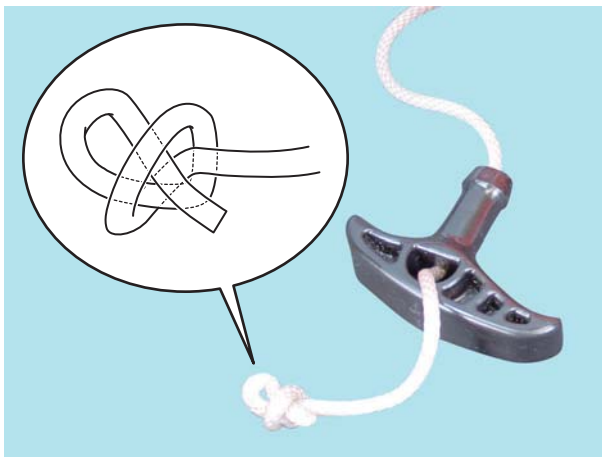

5. Pass the other end of starter rope through starter case, then pass starter rope through starter grip and make a knot as shown.
6. Tighten knot. Push knot into recess of starter grip.

2-3 Assembling starter

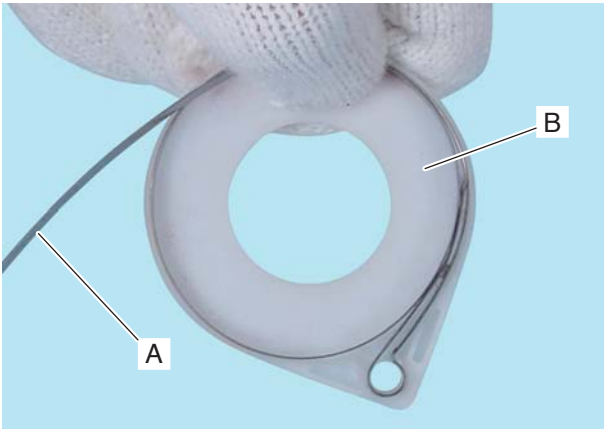

1. If rewind spring (A) is unwound from rewind spring case (B), wind the spring inside case as shown.

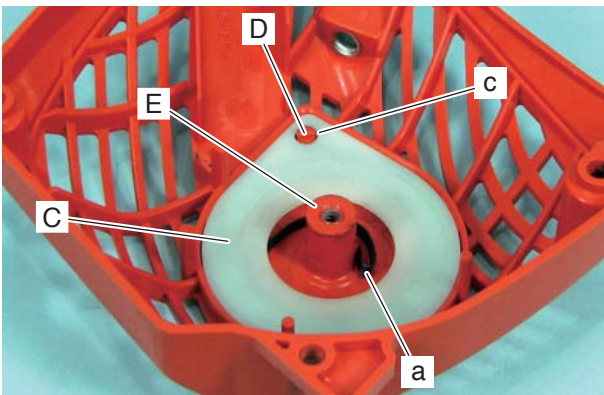

2. Carefully install rewind spring case assembly (C) on starter case, matching hole (c) with post (D). Hook (a) of rewind spring should contact with post (E) of starter case.

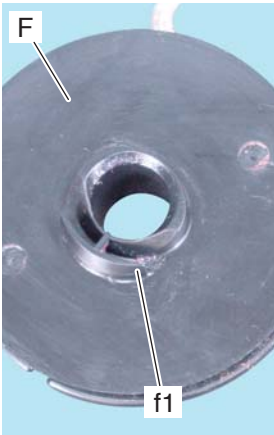

3. Assemble rope reel (F) engaging hook (f1) with hook (a) of rewind spring.



4. Check for proper engagement of rewind spring and rope reel by turning rope reel (F) clockwise and counterclockwise.

2-3 Assembling starter (continued)

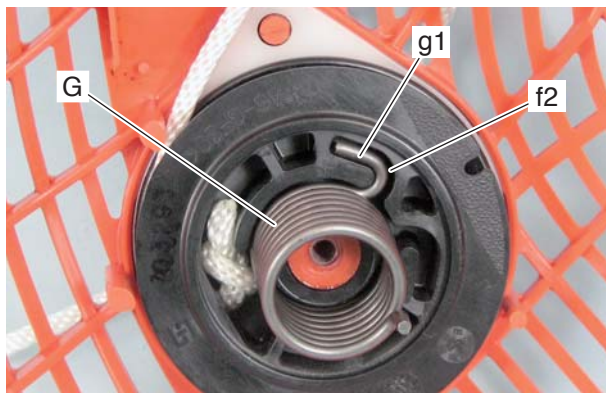

5. Install power spring (G), engaging hook (g1) with rope reel groove (f2).

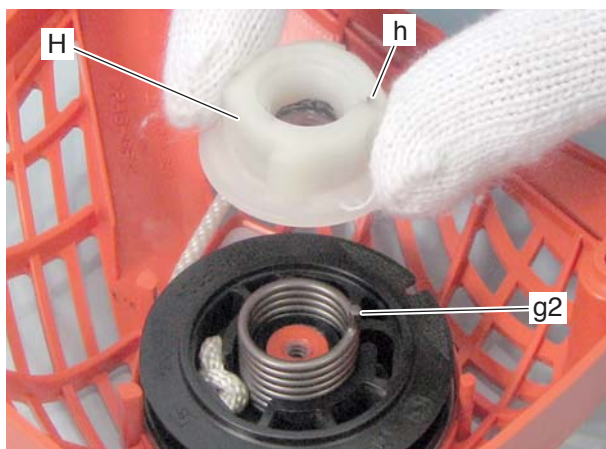

6. Install pawl catcher (H), engaging hole (h) with power spring top end hook (g2).

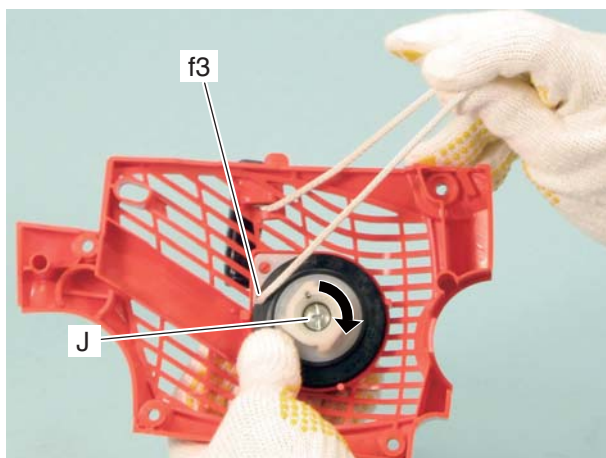

7. Reinstall screw (J) on starter post.

8. Pull out starter rope inside starter case. Rotate rope reel clockwise several turns with starter rope hooked at notch (f3) as shown. Hold rope reel to prevent it from unwinding and pull out starter grip to take the rope slack.



9. Pull starter several times to check rewind spring tension. If starter is not rewinding fully, increase spring tension by rotating rope reel one more turn clockwise following above step (8).

10. Pull out starter rope all the way, and check that rope reel can be rotated an additional half or more turn clockwise as shown, to prevent rewind spring from breaking.

11. If rope reel can not be turned clockwise, reduce tension by rotating rope reel counterclockwise one turn with starter rope hooked at notch (f3).

2-4 Replacing starter pawl

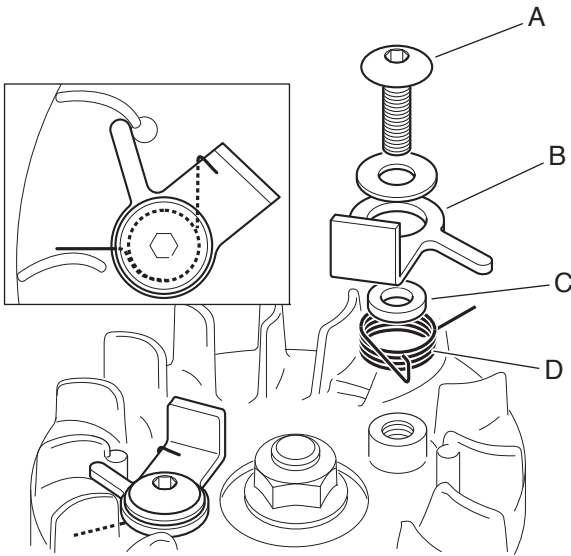

1. Remove starter assembly from unit.

2. Loosen bolt (A) and remove washer, pawl (B), spacer (C) and torsion spring (D). Replace damaged or worn parts.

NOTE: When it is hard to loosen bolt, install piston stopper 897537-30130 (E) in spark plug hole to stop crankshaft rotation and remove bolt easily.

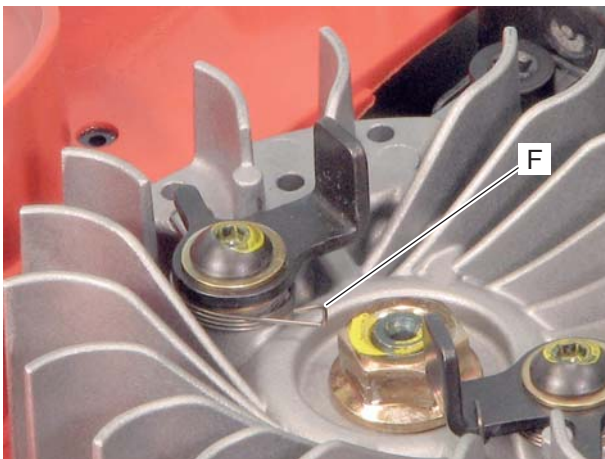
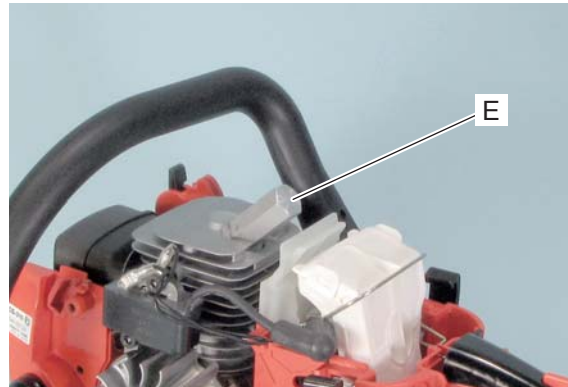

3. Install torsion spring, spacer, pawl, washer and bolt. To avoid pinching of torsion spring, install these parts without setting the end (F) of torsion spring on starter pawl. The bolt is pre-coated with sealant on the thread. If the sealant is peeled off, apply thread locking sealant (Loctite #242, Three-Bond #1324 or equivalent).

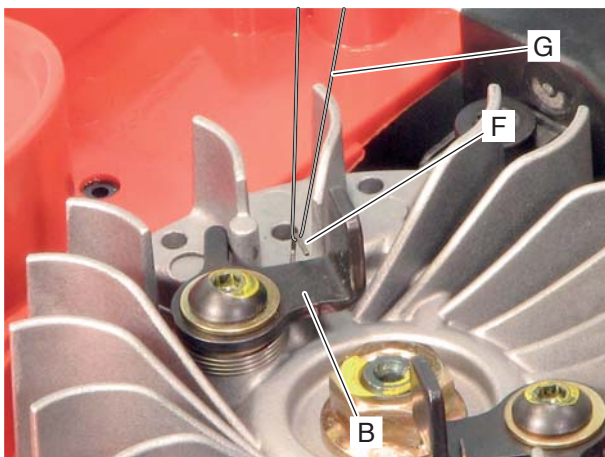

4. Using fine wire (G) or appropriate tool, place the end (F) of torsion spring on pawl (B), by hooking and passing under pawl as shown. Remove fine wire or tool.

5. Make sure pawl can move smoothly. If it does not move smoothly, check parts for correct installation.

3 IGNITION SYSTEM

- (A) Flywheel
- (B) Ignition coil
- (C) Spark plug
- (D) Spark plug cap coil
- (E) Spark plug cap
- (F) Switch lead
- (G) Ground lead
- (H) Ignition switch

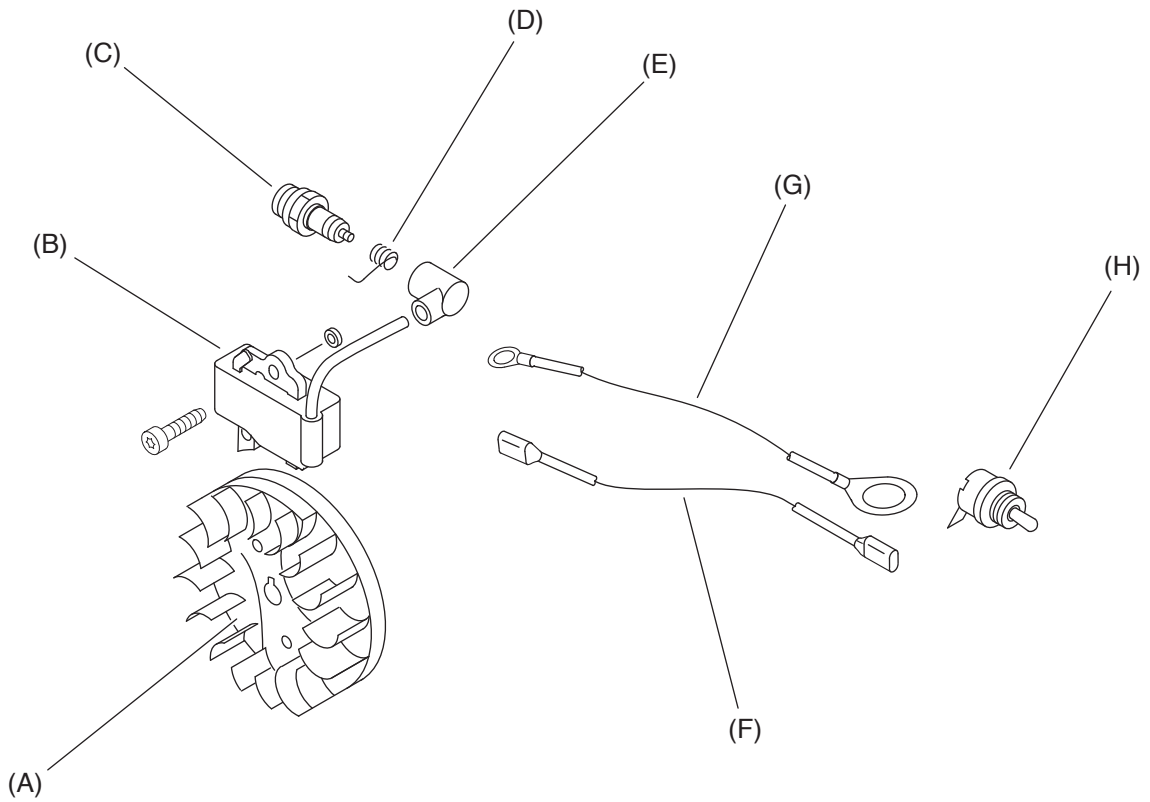

3-1 Troubleshooting guide

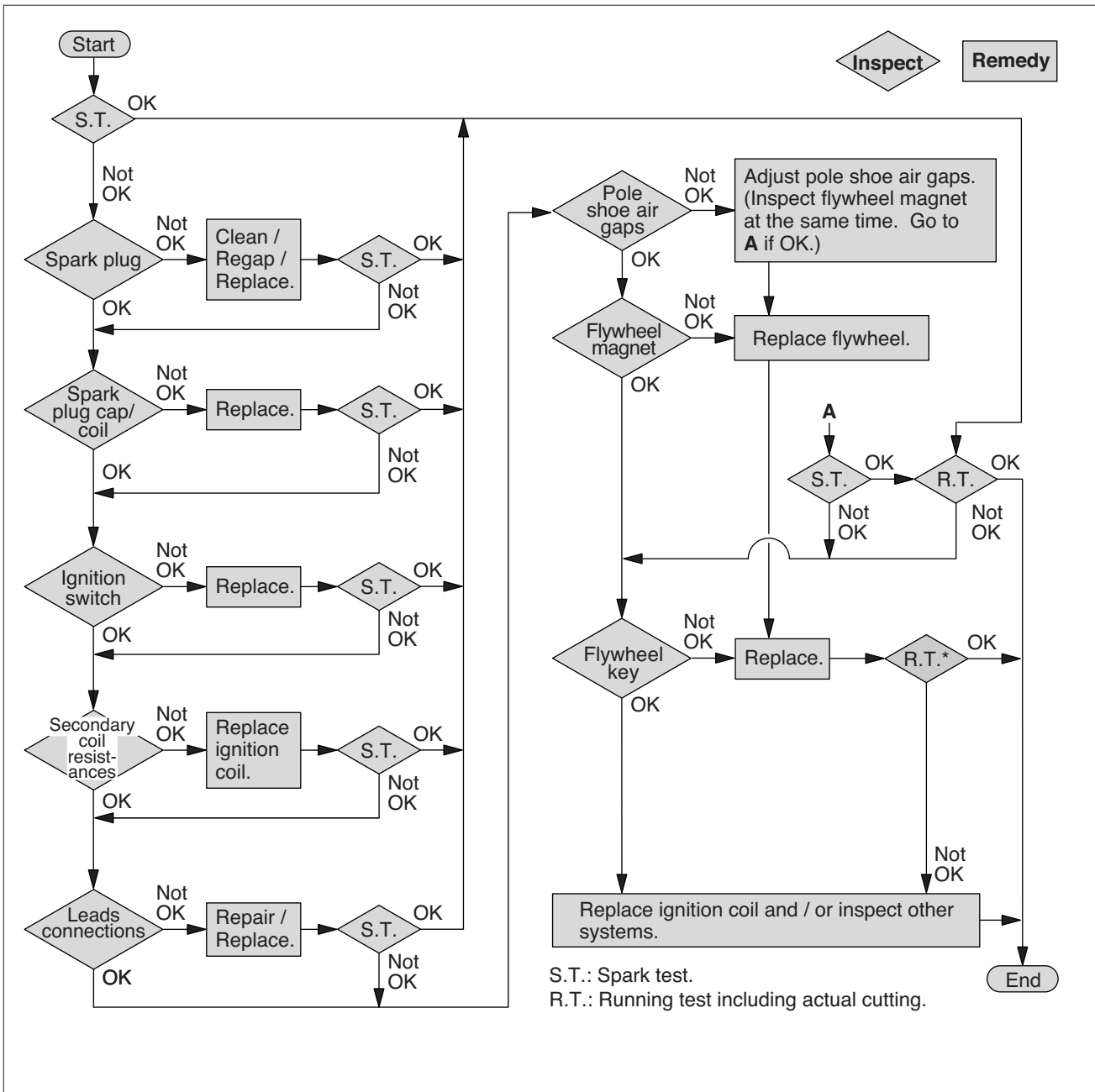

3-2 Testing spark

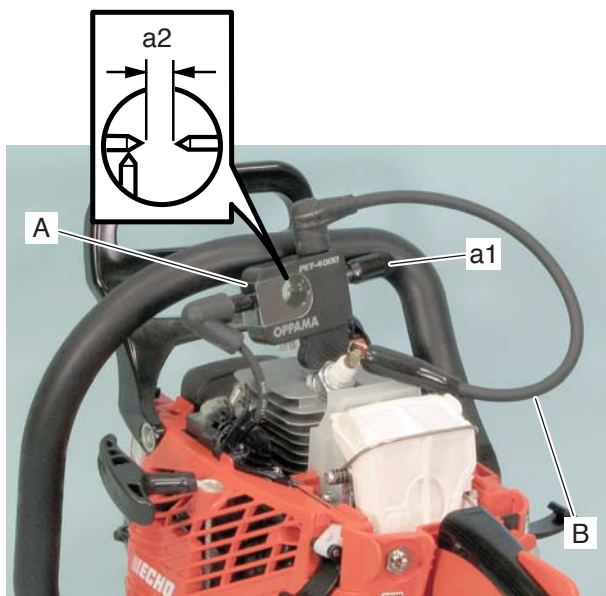

1. Remove cylinder cover. Remove spark plug cap from spark plug.

2. Connect spark plug cap to spark tester 990511-30023 (A), and connect spark tester lead (B) on spark plug as shown.

3. Screw in adjuster (a1) until the needle tips contact. Turn out adjuster (a1) 4 turns to set spark tester gap (a2) to 4 mm (0.16 in).

4. Turn ignition switch upward ("ON" position). Pull starter grip several times.

5. If spark is steady blue or white at the tester gap, ignition system is considered good.

6. If no spark exists or spark is intermittent in yellow, orange, or red, continue with further inspection.

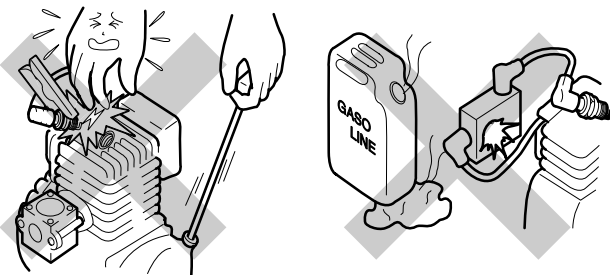
**DANGER**

*Do not test near spark plug hole without spark plug installed, otherwise there is a chance to ignite fuel mixture inside cylinder.

*Do not touch metal parts of spark tester while performing the test to avoid receiving electrical shock.

*Do not check spark in area where gasoline is spilled or flammable gases may exist.

3-3 Inspecting spark plug

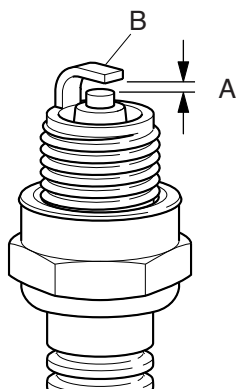

1. Remove spark plug to inspect for fouling, cracked or broken insulator, cracked outer electrode, or rounded center electrode. Clean or replace spark plug as required.

2. Set spark plug gap (A) by bending outer electrode (B).

Standard : 0.6 to 0.7 mm (0.024 to 0.028 in)

NOTE: Take care not to crack outer electrode when bending.

3. If engine does not start with correct spark plug, inspect if spark plug is wet or dry. If it is excessively wet or dry, inspect fuel system.

3-4 Inspecting ignition switch

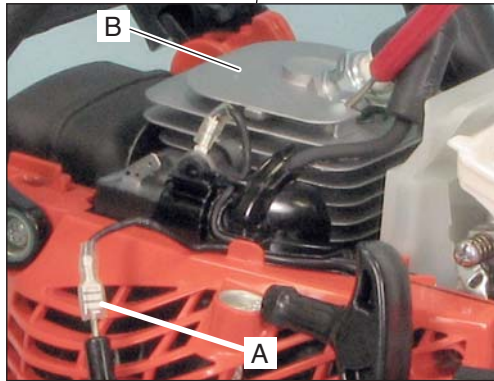
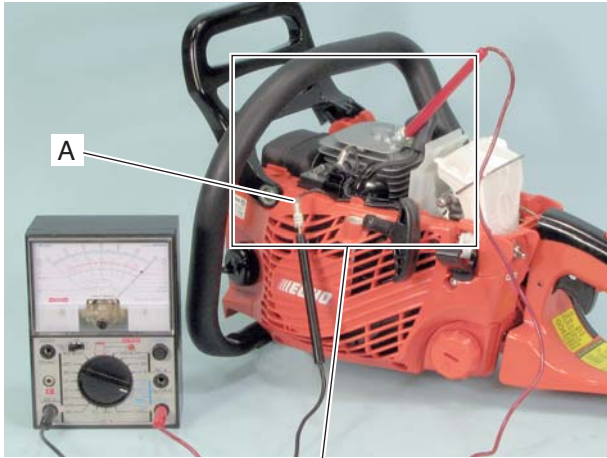

1. Remove cylinder cover.
2. Remove switch lead (A) from ignition coil.
3. Connect one probe of Ohm-meter or multi-meter to switch lead. Connect the other probe to cylinder fin (B).
4. When ignition switch is upward ("ON" position), tester should indicate infinite resistance.
5. When ignition switch is in "STOP" position, tester should show that the circuit is in conducting state (closed circuit).
6. If ignition switch is defective, replace with a new one.

3-5 Replacing ignition switch

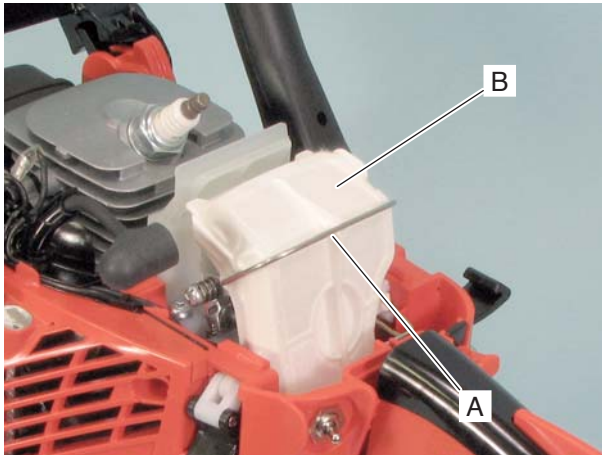

1. Remove cylinder cover.
2. Push down air filter retainer (A) and remove air filter (B).

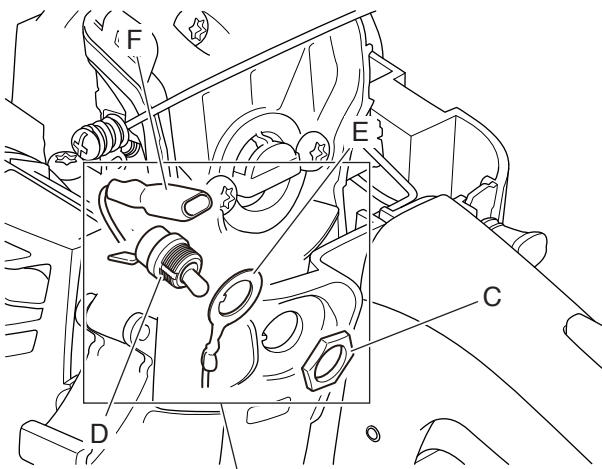

3. Loosen nut (C), and remove ignition switch (D) and ground lead (E) from the unit. Remove switch lead (F) from ignition switch.

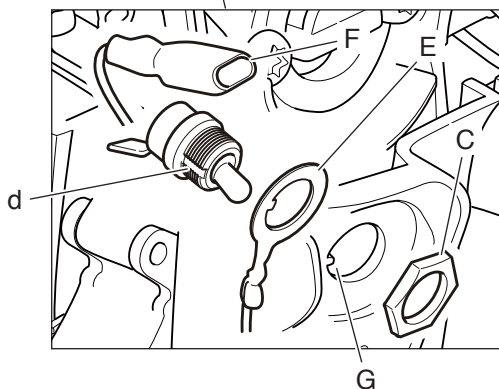

4. Assemble switch lead (F) to new ignition switch.
5. Assemble ground lead (E) and new ignition switch on the unit, aligning notch (d) of ignition switch with tab (G) of the unit. Fasten nut (C) on ignition switch.

3-6 Inspecting ignition coil resistance

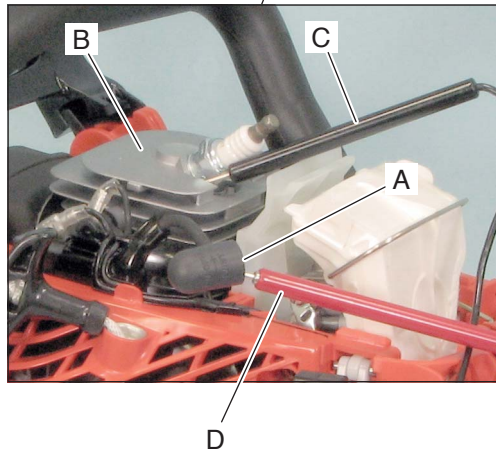
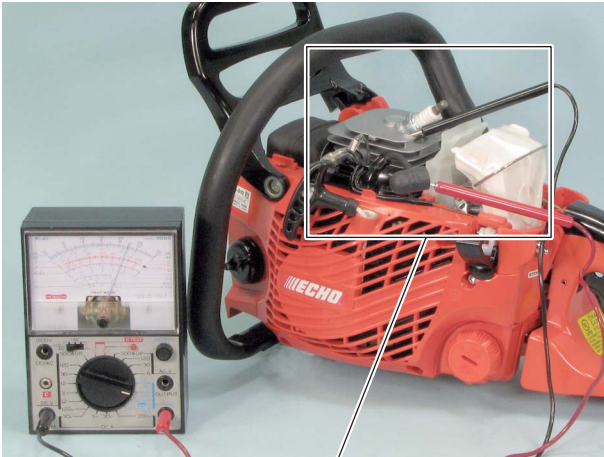

1. Remove cylinder cover.
2. Connect one probe of Ohm-meter or multimeter to spark plug cap coil (A).
3. Connect the other probe to cylinder fin (B) to measure secondary coil resistance. Secondary coil resistance should be in the range of 1.9 to 2.3 k Ω .
4. If the meter reading indicates infinite resistance, remove spark plug cap and spark plug cap coil, and measure resistance between the conduction wire of high tension lead and ignition coil core.
5. Keep probe (C) on cylinder fin (B). Remove probe (D) from spark plug cap coil (A) and connect it to ignition coil core to confirm that the circuit is in conducting state (closed circuit). If the circuit is not in conducting state, ensure conduction between ignition coil bolt and cylinder.
6. If the reading at step 3 or 4 is not in the range of 1.9 to 2.3 k Ω , replace with a new ignition coil (Go to "3-8 Replacing ignition coil").

3-7 Replacing spark plug cap and coil

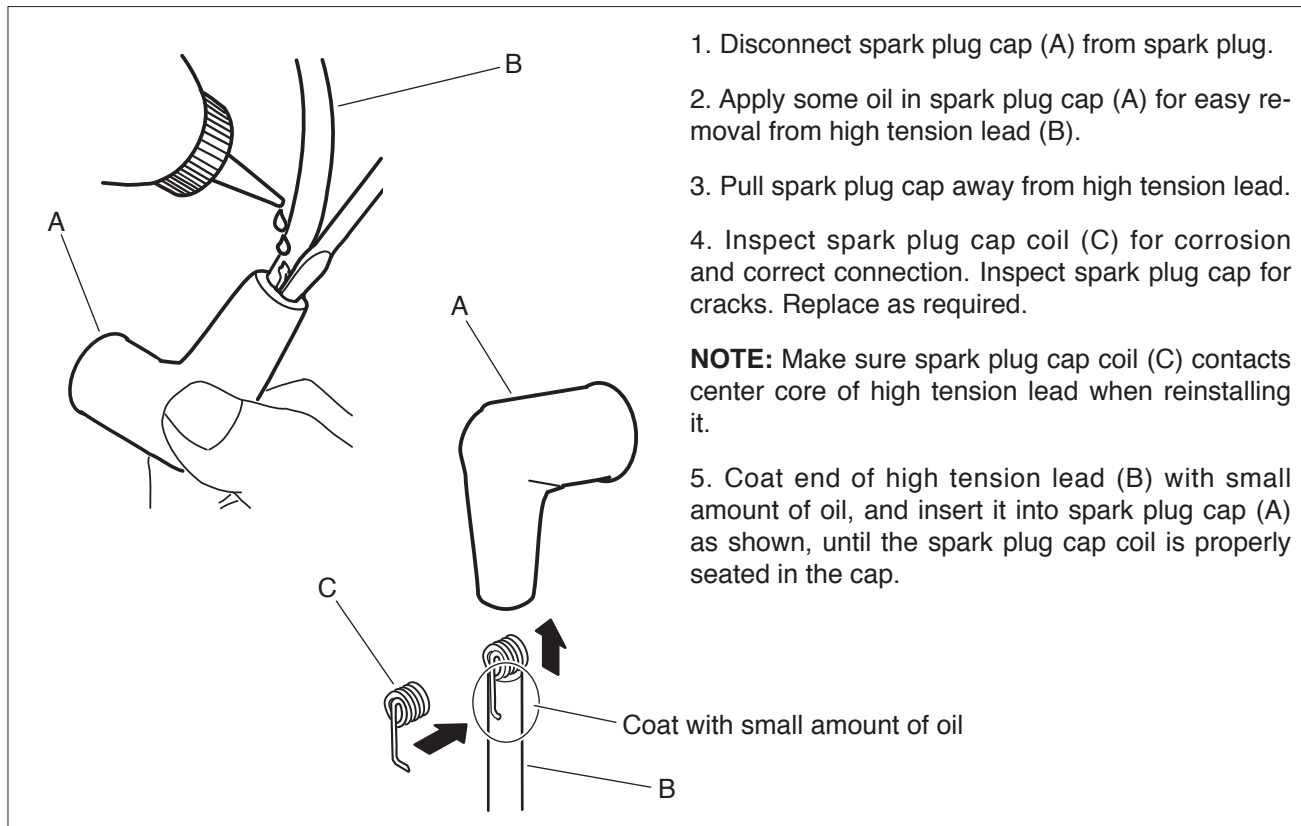

3-8 Replacing ignition coil

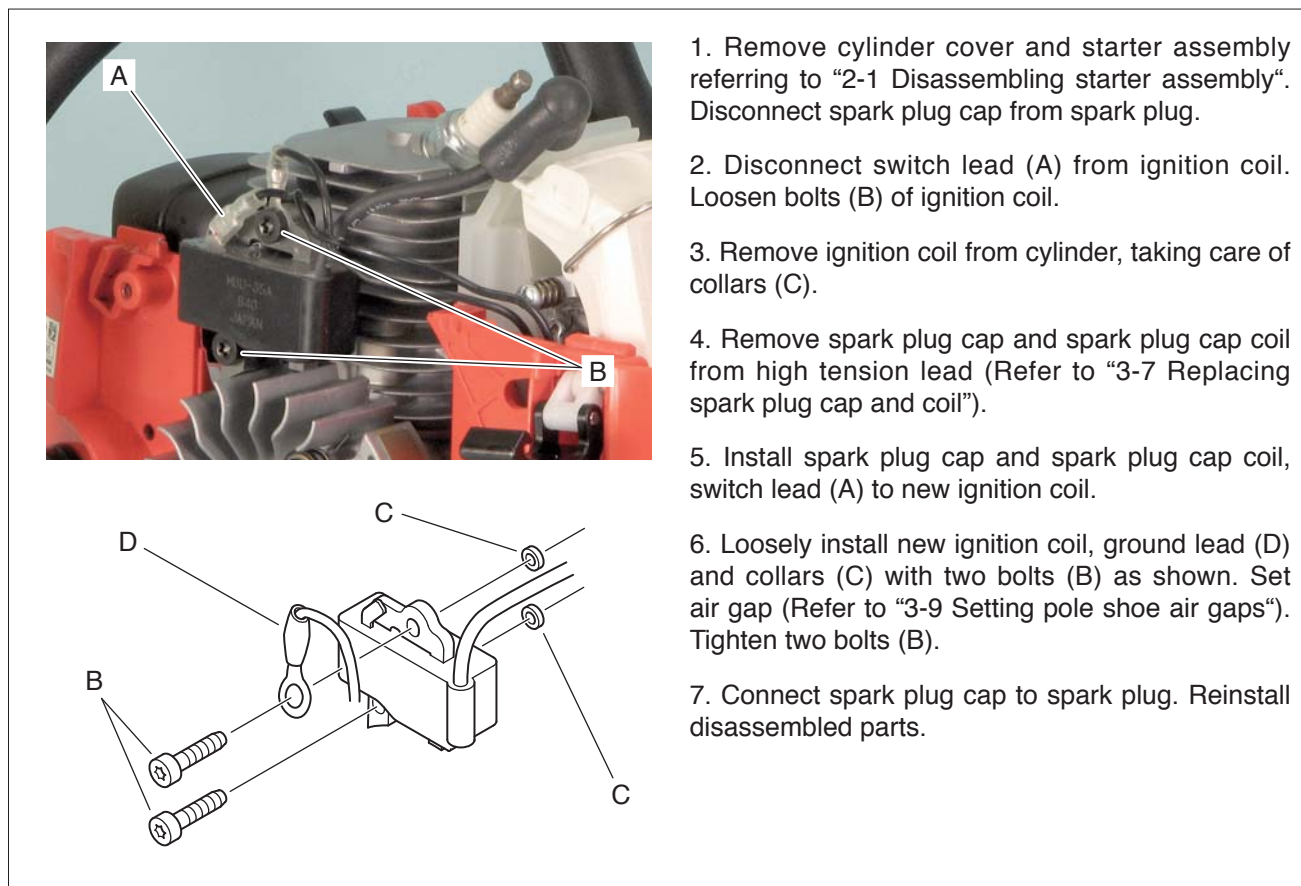

3-9 Setting pole shoe air gaps



1. Insert Module air gap gauge: 91004 (A) or 0.3 - 0.4 mm (0.012 - 0.016 in) thick feeler gauge between flywheel and ignition coil shoes.

2. Rotate flywheel until magnetic poles of flywheel face ignition coil shoes.

3. Hold ignition coil against flywheel and tighten the bolts to specified torque (Refer to "Service information 1-3 Torque limits"). After tightening bolts, remove Module air gap gauge: 91004 (A) (or feeler gauge).

NOTE: When air gap is too narrow, contact with flywheel may result. When the air gap is too wide, spark is weak.

3-10 Inspecting flywheel and key

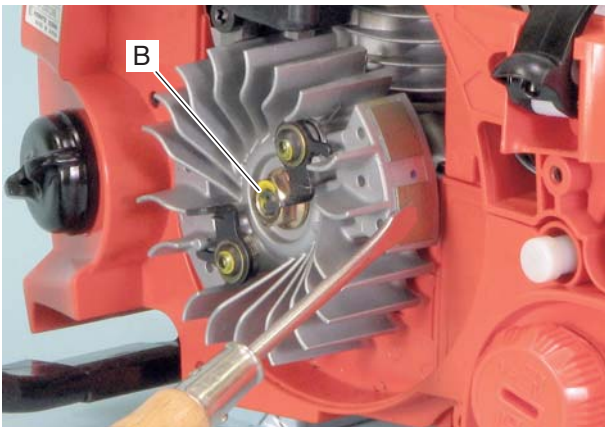

1. Inspect magnetic force of flywheel using flux meter, or bridging with a screwdriver as shown.

2. If magnetic force is weak, replace flywheel as follows.

3. Install piston stopper 897537-30130 (A) into spark plug hole by hand, to stop crankshaft rotation.

NOTE: Do not use power tool to remove nut (B). Otherwise, piston damage may occur.

4. Remove nut (B) by rotating counterclockwise.

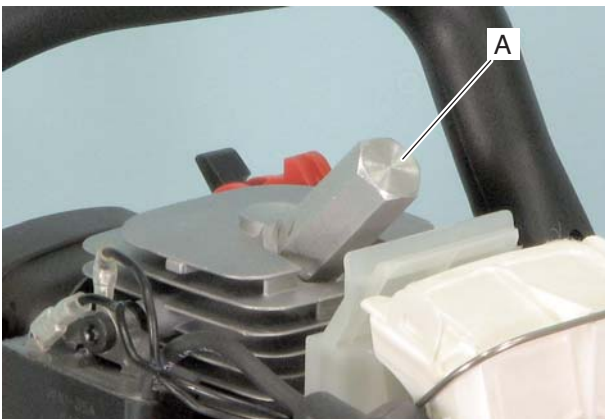

3-10 Inspecting flywheel and key (continued)

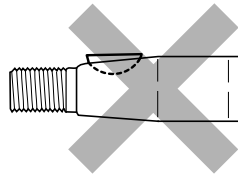
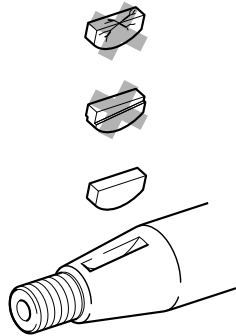
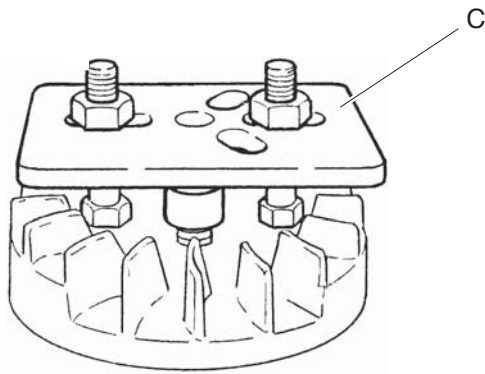

5. Remove starter pawls. Then set puller 897501-03938 (C) on flywheel as shown.

6. Tighten two nuts on the puller alternately to remove flywheel.

7. Inspect woodruff key for damage or shearing. Replace as required.

8. Wipe off oil from taper part of crankshaft and flywheel before assembling flywheel.

9. Install woodruff key into key groove.

10. Reinstall starter pawls (Refer to "2-4 Replacing starter pawl").

11. Align flywheel key groove with woodruff key on crankshaft. Install flywheel and fasten flywheel nut clockwise.

4 FUEL SYSTEM

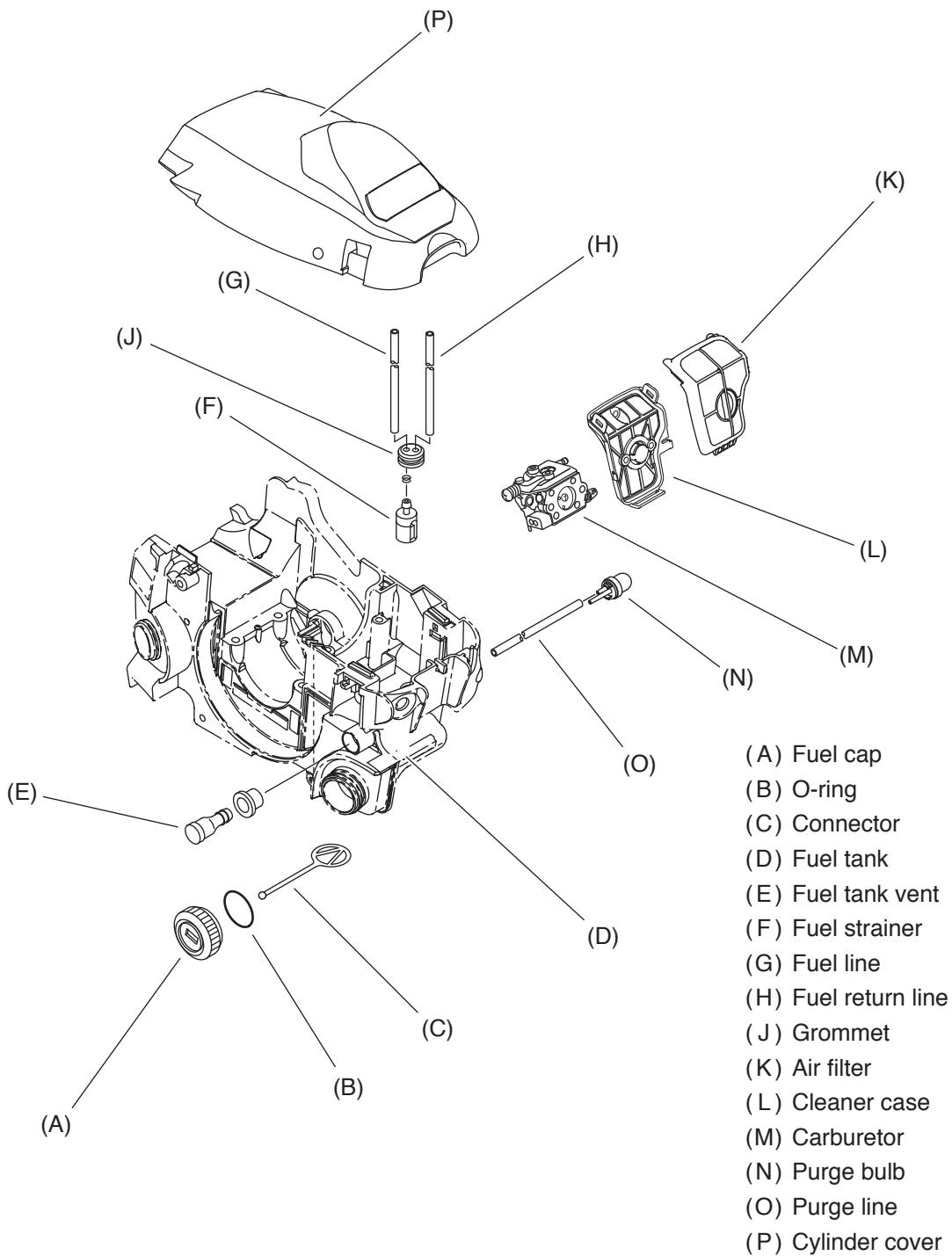

4-1 Inspecting air filter

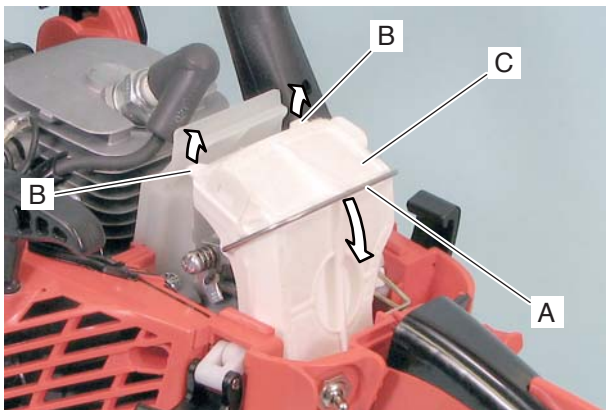

1. Close choke shutter. Remove cylinder cover.
2. Push down air filter retainer (A). Lift tabs (B) and remove air filter (C).

3. Inspect the surface of air filter. If blocked with dirt or dust, remove the obstruction using brush.

WARNING  **DANGER**

Wear eye protection when working with compressed air. Eye damage can occur from flying particles.

4. If heavily blocked with dirt or dust, clean air filter with compressed air.
5. Replace air filter with new one if heavily soiled or damaged.

4-2 Inspecting fuel cap and fuel strainer

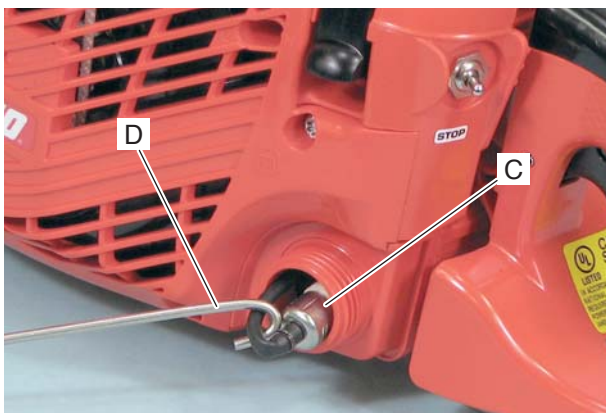
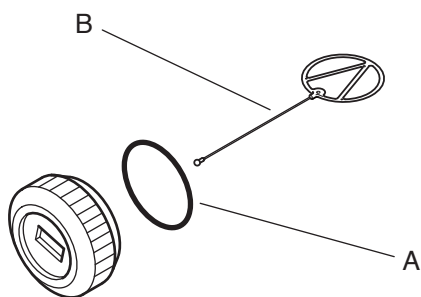

1. Remove fuel cap.
2. Inspect fuel cap for cracks and O-ring (A) for cuts or damage, and replace with new one as required.
3. Replace connector (B) if damaged.
4. Pull fuel strainer (C) from fuel tank using a wire hook (D). Clean fuel strainer. Replace if defective or heavily soiled.
5. Reinstall fuel cap.

4-3 Inspecting fuel tank and line

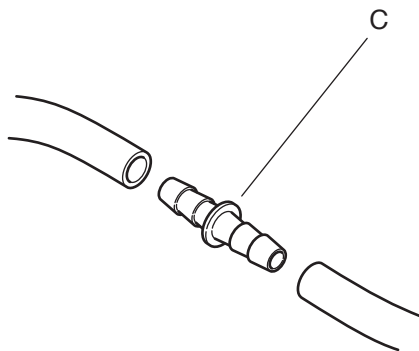
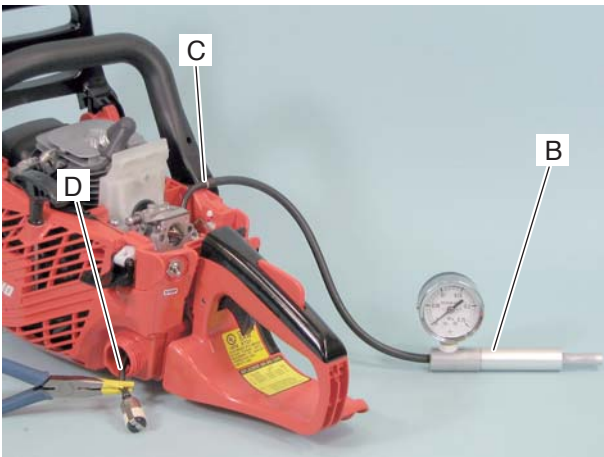
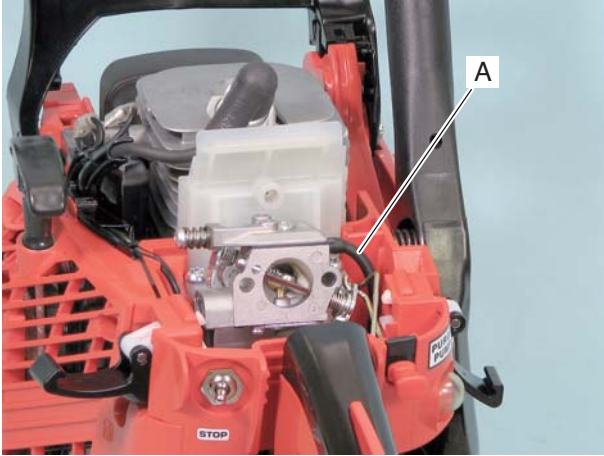

1. Clean fuel tank inside as required.
2. Remove cylinder cover, air filter and cleaner case.
3. Disconnect fuel line (A) from carburetor.

4. Connect pressure tester 897803-30133 (B) to fuel line.

NOTE: To connect pressure tester to fuel line, it is recommended to use pipe joint V186-000020 (C).

5. Remove fuel cap and pull out fuel strainer from fuel tank.
6. Pinch fuel line (D) with longnose pliers as shown.

NOTE: Wrap the ends of longnose pliers with tape (or cover with soft pipes) to protect fuel line from damage.

7. Apply pressure approx. 49 kPa (0.5 kgf/cm²) (7 psi).

8. If pressure drops, replace fuel line.

9. Put fuel strainer in fuel tank and fasten fuel cap securely.

10. Apply pressure approx. 9.8kPa (0.1 kgf/cm²) (1.4 psi).

11. Pressure should not drop. If pressure drops, leakage may occur from fuel cap, fuel cap O-ring, mating surface of fuel tank on rear handle, grommet, or tank vent. Inspect and replace defective part(s) with new one.

12. Remove pressure tester and connect fuel line to carburetor.

4-4 Inspecting and replacing tank vent

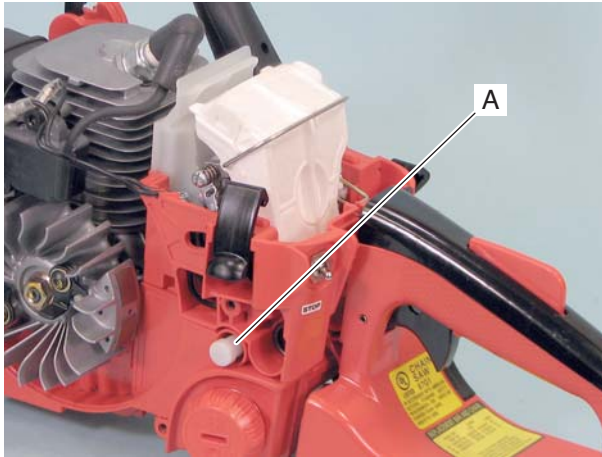

NOTE: Tank vent prevents a vacuum from forming in fuel tank when fuel in fuel tank is being consumed. When pressure in fuel tank becomes too high, tank vent releases the pressure.

1. Remove cylinder cover and starter assembly referring to “2-1 Disassembling starter assembly”. Remove tank vent (A) from fuel tank and connect pressure tester 91024 (B).

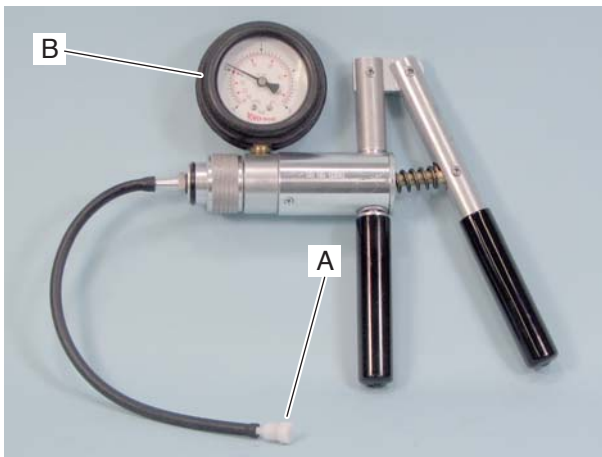

2. Apply pressure approx. 49 kPa (0.5 kgf/cm²) (7 psi). Make sure pressure is stable in range of 9.8 - 39.2 kPa (0.1 - 0.4 kgf/cm²) (1.4 - 5.7 psi).

3. If it is not in the range, gently clean tank vent with compressed air or replace with new one.

NOTE: Do not disassemble valves in tank vent assembly. Damage to valves will occur.

4. Apply negative pressure 19.6 kPa (0.2 kgf/cm²) (3 psi).

5. Tank vent should pass air freely without holding any pressure. If it does not, replace tank vent with new one.

4-4 Inspecting and replacing tank vent (continued)

NOTE: Inspection using 897803-30133

If pressure tester 91024 is not available, tank vent can be inspected with pressure tester 897803-30133 as follows.

1. Connect tank vent (A) to pressure tester 897803-30133 (B).

2. Apply pressure approx. 49 kPa (0.5 kgf/cm²) (7 psi). Make sure pressure is stable in range of 9.8 - 39.2 kPa (0.1 - 0.4 kgf/cm²) (1.4 - 5.7 psi).

3. If it is not in the range, gently clean tank vent with compressed air or replace with new one.

NOTE: Do not disassemble valves in tank vent assembly. Damage to valves will occur.

4. Remove cap (C) of tank vent, and clean sponge (D).

5. Cut pipe 363011-00210 (E: 7x11x170mm) and 382011-01110 (F: 9x13x350) in approx. 30mm (1 1/4 in) length, and connect them to pressure tester as shown. Connect tank vent (A) without cap to pipe as shown.

6. Plug hole (a) with finger and apply pressure 19.6 kPa (0.2 kgf/cm²) (3 psi). The pressure should hold steady.

7. Remove finger from hole (a). Tank vent should pass air freely without holding any pressure. If it does not, replace tank vent with new one.

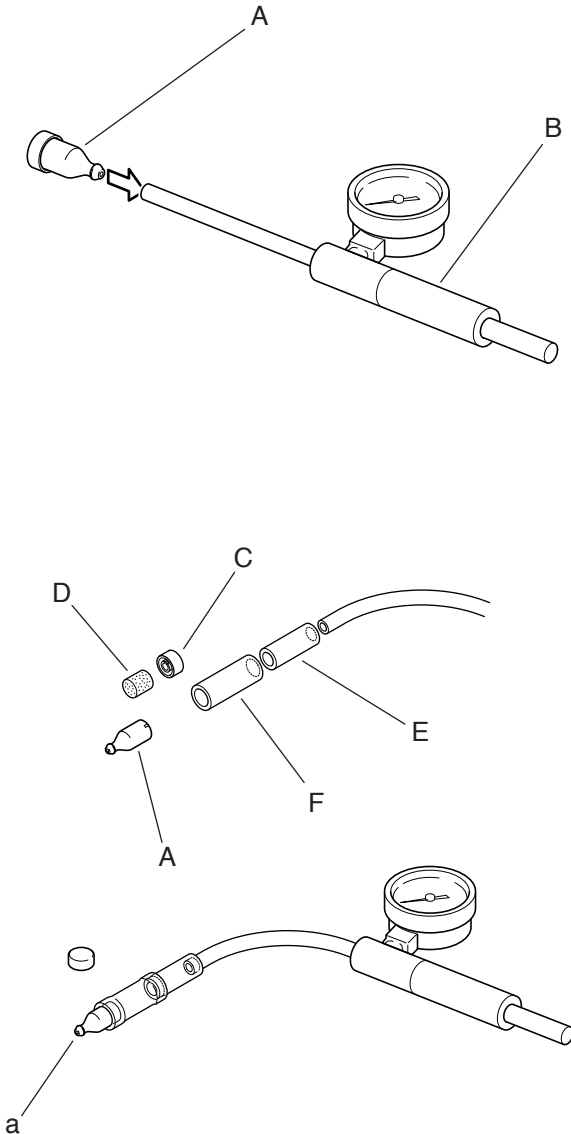

4-5 Replacing purge bulb

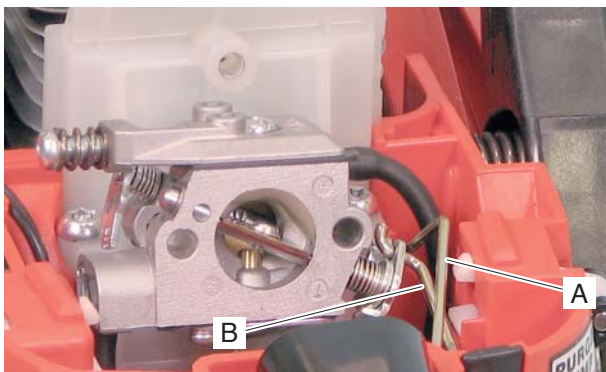

1. Remove cylinder cover, air filter and cleaner case.

2. Remove throttle rod (A) and choke rod (B) from carburetor.

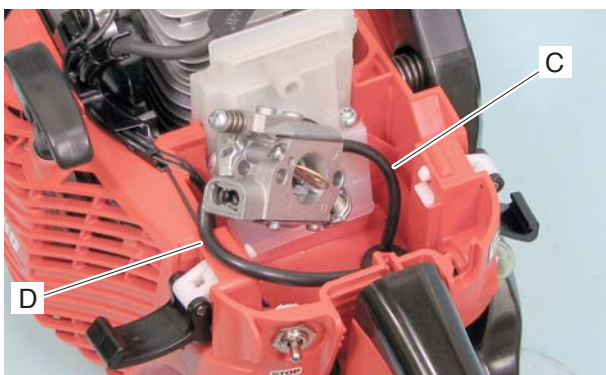

3. Remove fuel line (C) and purge line (D) from carburetor.

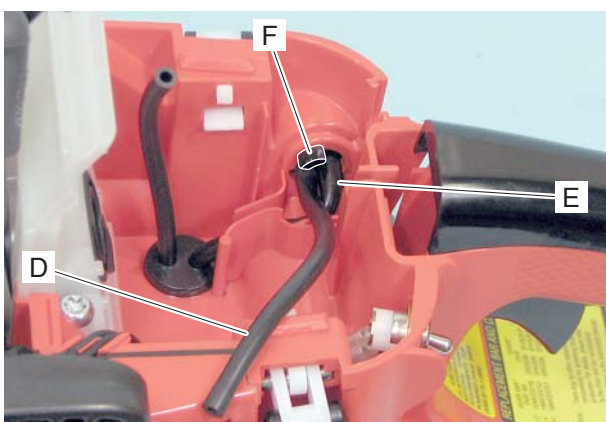

4. Remove purge line (D) and fuel return line (E) from purge bulb.

5. Push down hook (F) and remove purge bulb.

6. Install new purge bulb.

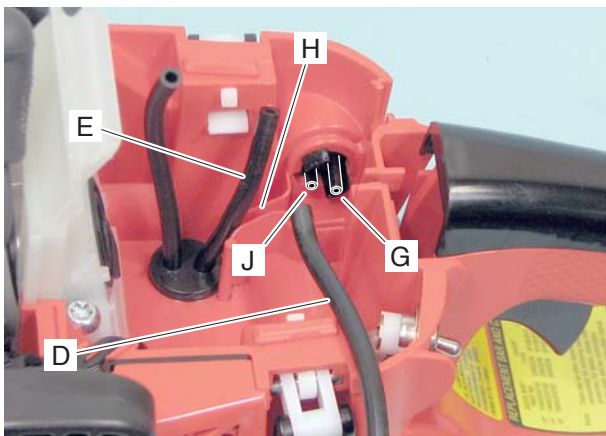

7. Connect fuel return line (E) to longer fitting (G), placing fuel return line in the bottom of groove (H) of the unit.

8. Connect purge line (D) to the other fitting (J). Place purge line in groove (H).

4-6 Replacing fuel line and fuel return line

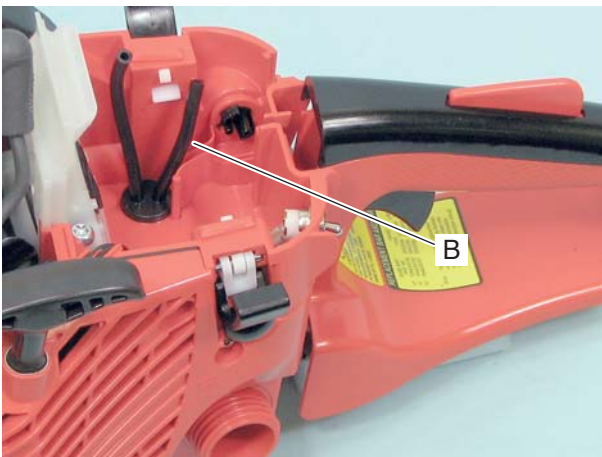
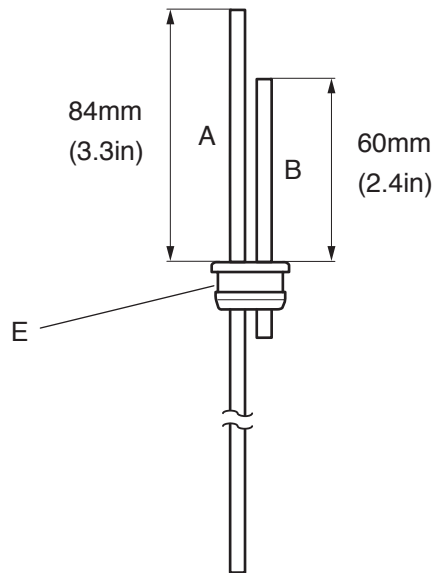
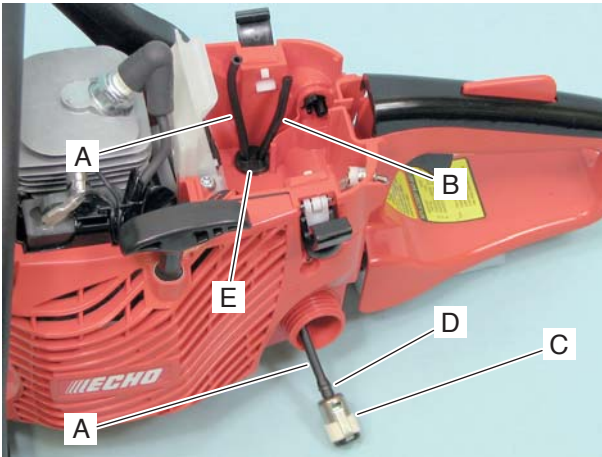

1. Remove cylinder cover, air filter and cleaner case.
2. Remove carburetor referring to “4-5 Replacing purge bulb”.
3. Inspect fuel line (A) and fuel return line (B). Replace them if defective.
4. To replace fuel line and fuel return line, remove fuel cap and remove fuel strainer (C) and clip (D) from fuel line (A).
5. Remove grommet (E) from the unit together with fuel line (A) and fuel return line (B).

6. Install fuel line (A) and fuel return line (B) on grommet (E) as shown.

7. Install assembled grommet on the unit.

NOTE: Assemble grommet, with fuel return line (B) oriented towards rear handle.

8. Pull out fuel line from fuel tank and install clip and fuel strainer to fuel line.
9. Reinstall carburetor, referring to “4-15 Installing carburetor”.
10. Reinstall cleaner case, air filter and cylinder cover.

4-7 Adjusting carburetor

4-7-1 General adjusting rules

A. Before starting the unit for adjustment, check the following items.

1. The correct spark plug must be clean and properly gapped.
2. The air filter element must be clean and properly installed.
3. The muffler exhaust port must be clear of carbon.
4. The fuel lines, tank vent and fuel filter are in good condition and clear of debris.
5. The fuel is fresh (> 89 octane: RON) and properly mixed at 50:1 with "ISO L-EGD" or "JASO FC/FD" 2-stroke oil.
6. The recommended bar and chain must be installed, and properly tensioned.

NOTE: In order to achieve proper carburetor adjustment, a 30 or 35 cm bar and chain combination should be installed on the unit, otherwise serious engine damage will occur due to overspeeding.

B. Set L and H mixture needle anticlockwise to rich side stop. Start and run engine for two minutes alternating r/min between WOT and idle every 5 seconds. Adjust idle adjust screw to 3,200 +/- 200 rpm. Adjust H mixture needle to 12,500 +/- 300 rpm with limiter cap. If engine does not run correctly after this adjustment, proceed to the next step 2-2.

IMPORTANT: After adjusting carburetor according to the steps 2-2 and 2-3, the limiter cap(s) must be installed on L and H mixture needle(s) to comply with Emission directive.

4-7-2 Presetting idle adjust screw, L mixture needle and H mixture needle

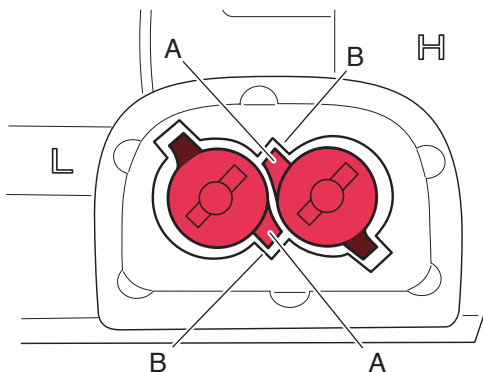

Tools Required: Small screwdriver with 2.5 mm blade, electronic tachometer P/N 990511-30017, limiter cap removal tool with 2.5 mm left-hand thread P/N 91019. Parts Required: (2) limiter caps P/N P003-000010.

1. Turn the L and H mixture needles anticlockwise to rich side stop to align limiter cap tab (A) with locating slot (B), using 2.5 mm blade screwdriver.

NOTE : If cap tabs (A) misalign with locating slots (B), the cap cannot be removed and the centre hole threads will strip. If center hole threads strip, use 3 mm limiter cap removal tool P/N 89802 to remove the limiter cap.

4-7 Adjusting carburetor (continued)



2. Screw 2.5 mm limiter cap removal tool P/N 91019 anticlockwise into centre hole of limiter cap until tab of the limiter cap just comes out of the locating slot.

NOTE : DO NOT COMPLETELY REMOVE LIMITER CAP FROM CARBURETOR!

If the first limiter cap is removed completely, the second limiter cap can be misaligned while inserting the cap removal tool. The cap tabs will be misaligned with location slots and the centre hole threads will strip. If centre hole threads strip, use 3 mm diameter thread wood screw to remove the limiter cap.

3. Remove the limiter cap removal tool from the limiter cap by turning the tool clockwise, leaving the limiter cap in place.

4. Screw 2.5 mm limiter cap removal tool P/N 91019 anticlockwise into centre hole of remaining limiter cap until the limiter cap is removed from the mixture needle completely. Remove the limiter cap from limiter cap removal tool by turning clockwise, then screw limiter cap removal tool into centre hole of previous limiter cap to remove completely.

5. Turn L and H mixture needle clockwise until lightly seated, then turn both mixture needles anticlockwise for initial setting as follows:

L mixture needle: 2 1/2, H mixture needle: 2 1/4

NOTE : If needles are forced during seating, damage to carburetor may occur.

6. Remove cleaner lid and air filter to see that Idle adjust screw contacts the throttle plate. Turn Idle adjust screw anticlockwise and set the screw until the tip just contacts the throttle plate. Then turn Idle adjust screw 7/8 turns clockwise. Reinstall air filter, and cleaner lid.

4-7 Adjusting carburetor (continued)

4-7-3 Adjusting carburetor

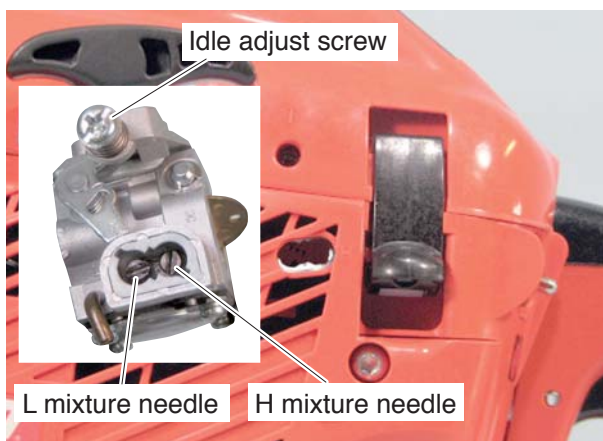

1. Start and warm engine for 1 minute alternating engine speed between WOT and idle every 5 seconds. Turn H mixture needle anticlockwise until engine speed drops to approx. 12,500 rpm at WOT.

NOTE: Do not run engine at high speed without load longer than 10 seconds, or engine damage may occur.

2. Adjust L mixture needle using 2.5mm blade screwdriver to reach maximum engine r/min just before lean r/min drop off.

3. Set idle speed to 3,700 r/min by turning Idle adjust screw. Engine speed should be stable at 3,700 +/- 50 r/min after idle adjust screw adjustment.

4. Turn L mixture needle anticlockwise reducing engine idle speed 500 r/min to set idle speed at 3,200 r/min. The idle speed range is 3,100 - 3,300 r/min.

NOTE: Engine speed must be allowed to stabilize a minimum of 20 seconds after each adjustment of L mixture needle to assure accurate tachometer readings.

5. Before adjustment, WOT engine speed should be less than or equal to 12,500 r/min. If r/min is higher, turn H mixture needle anticlockwise until 12,500 r/min is achieved. To make the final WOT engine speed adjustment, turn H mixture needle clockwise in 1/8 turn increments with the engine at idle. After each adjustment, accelerate to WOT, and check r/min. The final r/min should fall within 12,750 - 12,950 r/min.

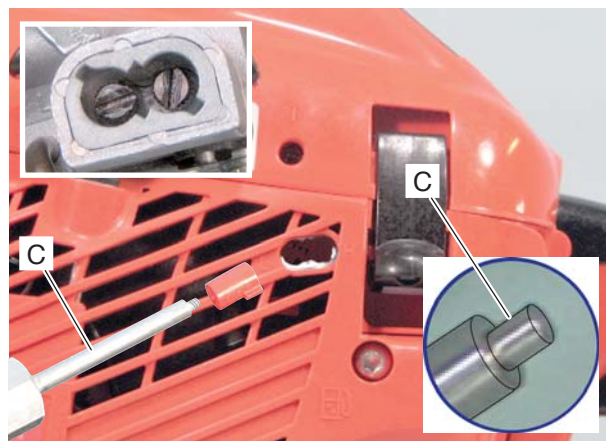

6. After adjusting carburetor, put new limiter cap on the other side (c) of limiter cap tool (C) as shown, and press the limiter caps to the bottoms on L and H mixture needles respectively.

NOTE : Align the limiter cap's tabs (A) with locating slots (B) in extended housing of carburetor.

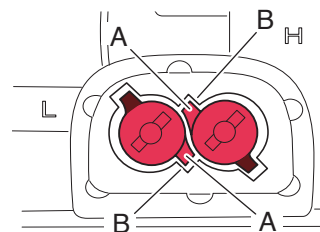

IMPORTANT: The limiter caps must be properly installed on L and H mixture needles to comply with Emission Directive.

7. Start engine, and verify engine idle speed ranges from 2,800 to 3,600 r/min, and WOT engine speed ranges from 12,000 to 13,000 r/min. Make sure the chain does not rotate when engine is idling. When final adjustment is completed, the engine should idle, accelerate smoothly, and attain WOT per above specifications.

NOTE : The initial carburetor settings for Idle adjust screw, Idle and Hi speed mixture needles are intended to start and run the engine before final carburetor adjustments are made to conform the unit to meet Emission Directive. The actual number of turns needed for engine operation may vary.

4-8 Winter plug



When it is cold weather and acceleration is poor, release winter plug.

1. Winter plug is located inside cylinder cover (A).



2. Picture shows “warm weather position” of winter plug (B).

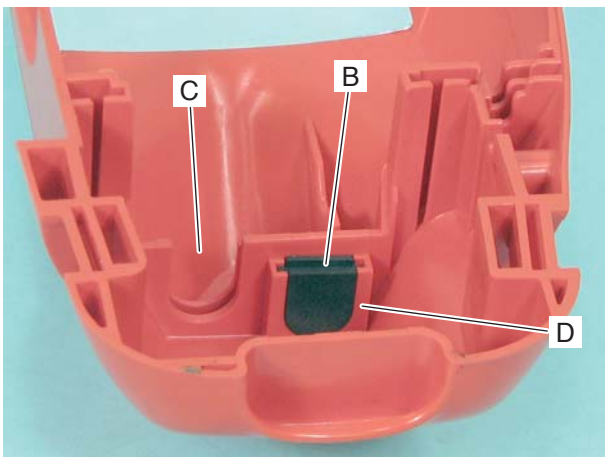

3. Remove winter plug (B) to open vent-opening (C) and introduce warm air from cylinder side to carburetor box.

4. Place winter plug (B) in storage position (D).

NOTE: In order to avoid carburetor vapor lock, return winter plug (B) to “warm weather position” when temperature is above freezing.

4-9 Testing carburetor



NOTE: To perform this test, carburetor interior should be wet with fuel. If dry, a little leakage may occur from diaphragms and/or inlet needle seat.

1. Remove cylinder cover, air filter and cleaner case. Disconnect fuel line from carburetor. Connect pressure tester 897803-30133 (A) to carburetor fuel inlet.

2. Apply pressure approx. 98 kPa (1 kgf/cm²) (14 psi).

3. If pressure remains steady, follow step 4 and 5. If pressure drops, proceed to step 6.

4. Pull starter grip. Pressure tester reading should drop and remain above 49 kPa (0.5 kgf/cm²) (7 psi).

5. If reading does not drop, inspect inlet needle valve for sticking or metering lever height is too low.

6. If pressure drops at step 2, or if pressure drops below standard figure at step 4, remove carburetor from the unit, disconnecting purge line, throttle rod and choke rod.

7. Submerge carburetor in suitable clean solvent to locate the leak by applying pressure approx. 98 kPa (1 kgf/cm²) (14 psi).

8. If air bubbles come out between pump cover and carburetor body (B), inspect pump diaphragm, pump gasket, and diaphragm seat of carburetor body (Refer to "4-13 Inspecting diaphragm").

9. If air bubbles come out from throttle bore (C), inspect inlet valve, metering lever spring, and metering lever height (Refer to "4-12 Inspecting inlet needle valve").

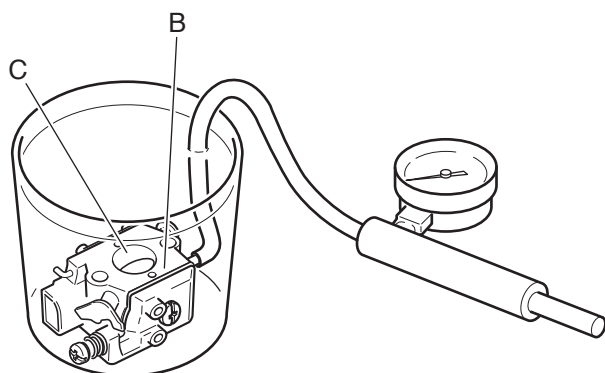

4-10 Inspecting crankcase pulse passage

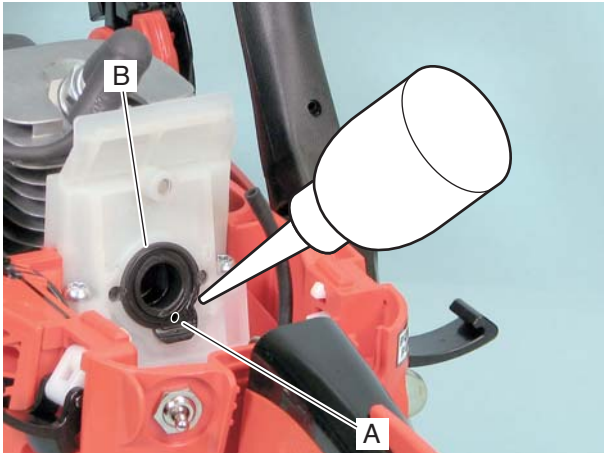

1. Drop a little oil in pulse hole (A) on intake bellows (B).
2. Remove spark plug and pull starter grip several times. Oil should spit back from the hole.
3. If not, inspect whether pulse passage is clogged. Repair or replace as required.

4-11 Inspecting metering lever height

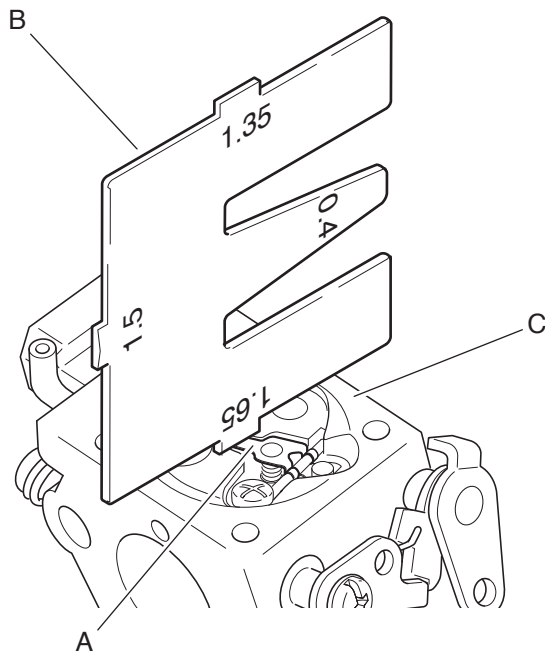

1. Remove carburetor.
 2. Remove metering diaphragm cover, metering diaphragm and gasket.
 3. Inspect metering lever (A) height by Metering lever gauge 897563-19830 (B).
- Metering lever height: 1.65 mm (0.065 in) lower than diaphragm seat (C).
4. If necessary, gently bend metering lever up or down to set metering lever to proper position.

NOTE: When metering lever is:

Too high → Fuel flooding occurs

Too low → Fuel starvation / overheating occurs

4-12 Inspecting inlet needle valve

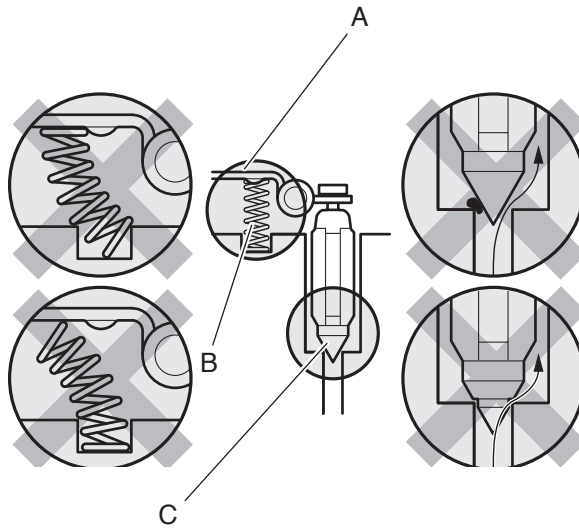

1. Remove metering lever (A) and pivot pin. Remove spring (B) and inlet needle valve (C).

2. Inspect inlet needle valve if worn or sticky. Clean or replace as required.

NOTE: Causes of fuel flooding from carburetor to cylinder are as follows:

- Improper assembling of metering lever and spring.
- Dirt between inlet needle valve and valve seat.
- Worn inlet needle valve tip.

3. Clean inlet needle valve seat using suitable clean solvent (do not use metal tools).

4. Reassemble inlet needle valve, spring, metering lever and pivot pin.

NOTE: Insure proper metering lever installation as follows.

- (1) Spring is seated in its hole at chamber floor.
- (2) Spring is under dimple of metering lever.
- (3) metering lever fork is holding inlet needle valve.

4-13 Inspecting diaphragm

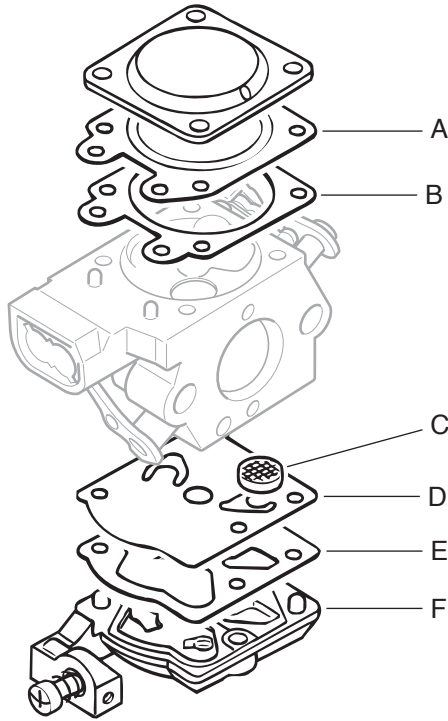

1. Inspect metering diaphragm (A) for hardening, distortion, or pin hole. Replace as required.
2. Remove pump cover (F), pump diaphragm (D) and pump gasket (E).
3. Inspect pump diaphragm (D) and replace if hardened or curled at valve tabs.
4. Inspect metering gasket (B) and pump gasket (E) and replace if defective.
5. Inspect inlet screen (C) if blocked, remove and clean it, or replace.
6. Clean fuel passages in carburetor body with compressed air.

NOTE: Before cleaning metering side with compressed air, turn “H” needle clockwise until lightly seated and remove inlet needle valve. Otherwise, main nozzle check valve and inlet needle valve spring may be damaged by the compressed air.

4-14 Replacing Welch plug

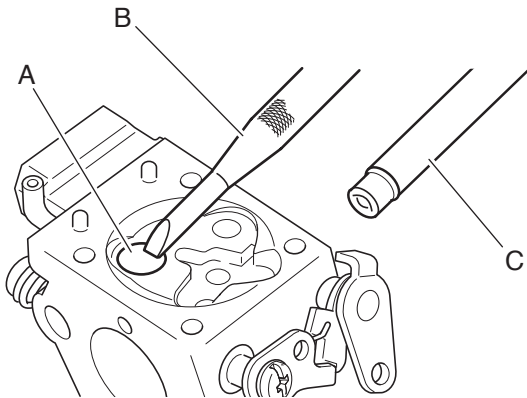

If engine does not run smoothly even after readjusting carburetor and inspecting carburetor parts, inspect low speed ports on carburetor as follows:

1. Remove metering lever and related parts to protect them from damage.
2. To remove Welch plug (A), punch the remover tool (B) through Welch plug at low angle and pry it out.

NOTE: Remover tool (B) is included in Welch plug tool (Part number: 500-500).

3. Clean low speed ports with compressed air.
4. Place a new Welch plug over the opening and gently tap it until flush using welch plug installer (C).
5. Install all removed parts to carburetor body.

4-15 Installing carburetor

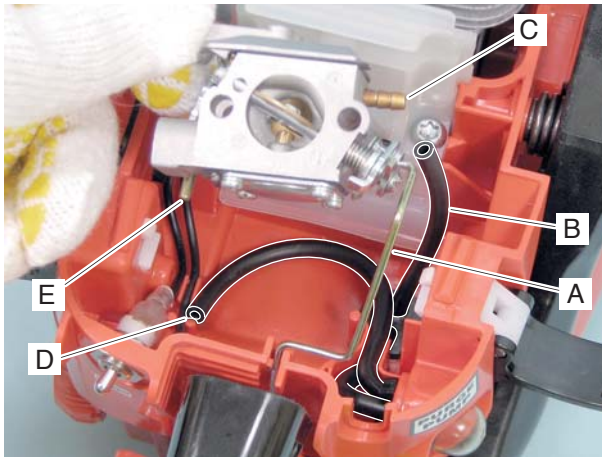

1. Connect throttle rod (A) to carburetor.
2. Connect fuel line (B) to carburetor fuel inlet (C). Connect purge line (D) to carburetor fuel outlet (E).



3. Connect choke rod (F) to carburetor. Install choke rod to the unit, with choke grommet (G).

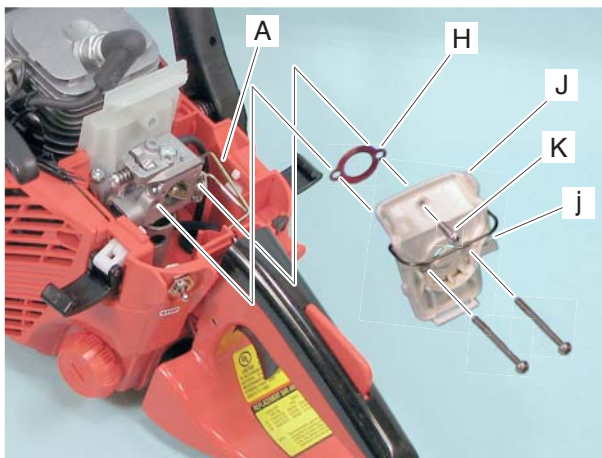

4. Install carburetor together with gasket (H) and cleaner case (J) with two bolts, passing throttle rod (A) through notch (j) of cleaner case.
5. Secure cleaner case (J) with screw (K).

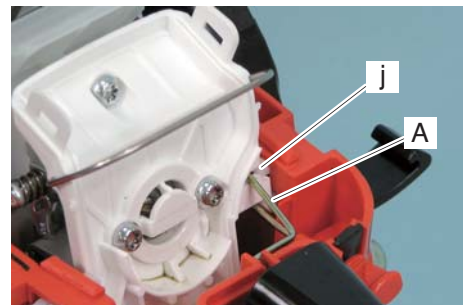

5 CLUTCH SYSTEM

- (A) Worm gear
- (B) Clutch plate
- (C) Clutch plate
- (D) Clutch spring
- (E) Clutch shoe
- (F) Clutch hub
- (G) Clutch assembly
- (H) Needle bearing
- (J) Clutch drum
- (K) Washer
- (L) E-Ring

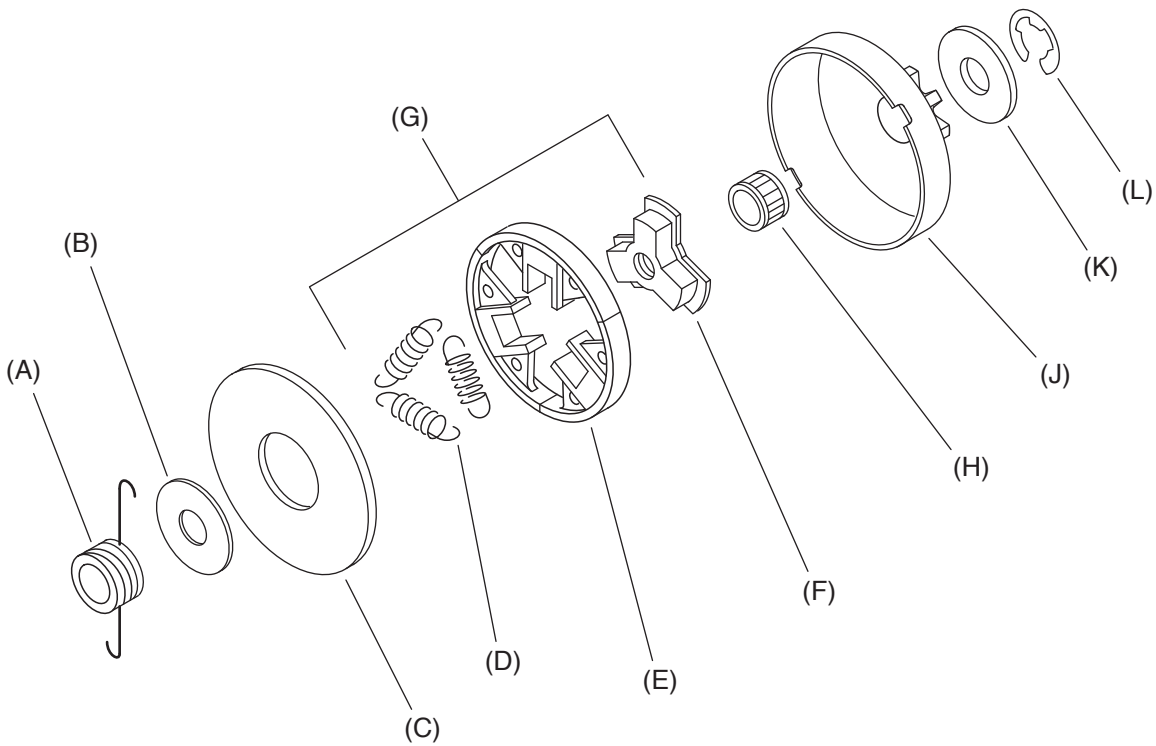

5-1 Inspecting clutch parts

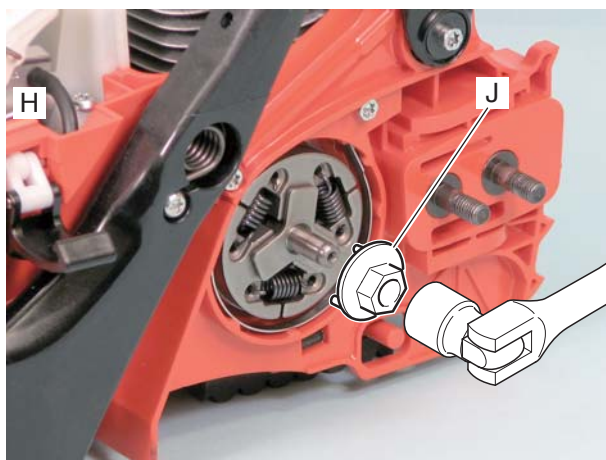
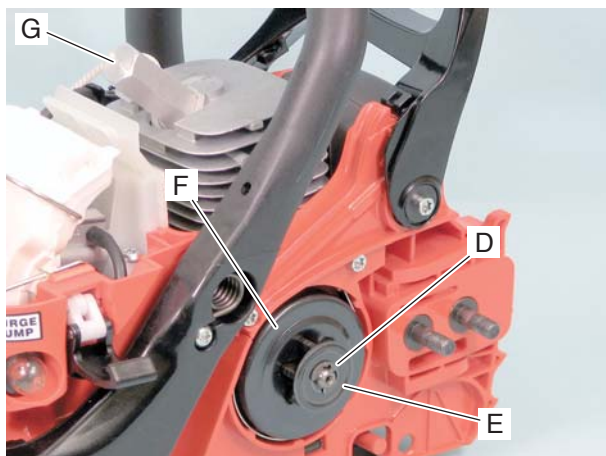
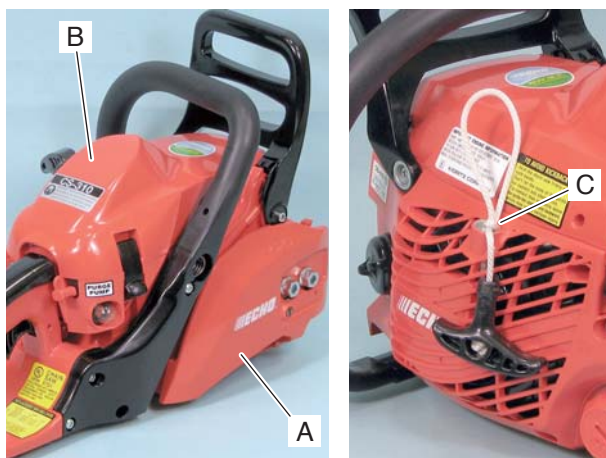

1. Remove sprocket guard (A) and cylinder cover (B).

NOTE: If starter assembly is installed, pull starter rope out about 20 cm (8 in), and make a temporary knot (C) to prevent starter damage when installing clutch assembly.

2. Remove E-ring (D) and washer (E).

3. Remove clutch drum (F) with needle bearing inside.

4. Disconnect spark plug cap and remove spark plug.

5. Install piston stopper 897537-30130 (G) in spark plug hole to stop crankshaft rotation.

6. Rotate clutch assembly (H) clockwise by hand until it cannot be rotated further.

7. Loosen clutch assembly (Left-hand thread) rotating clockwise with clutch tool 897505-16133 (J) and remove it.

NOTE: Do not use power tools. Otherwise, piston damage may occur.

8. Remove two clutch plates and worm gear.

9. Inspect clutch shoes for wear and spring for weakness or damage. Replace clutch parts as required.

10. Inspect clutch drum. Replace if deformed or worn out.

11. Inspect needle bearing and worm gear for damage, discoloration or deformation. Replace as required.

5-2 Replacing clutch parts

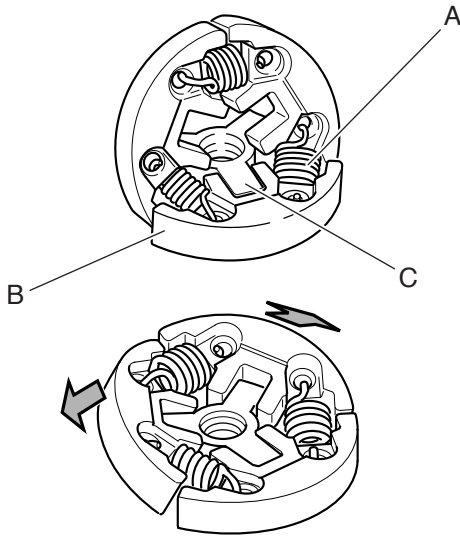

1. Install clutch spring (A) to clutch shoes (B).
2. Set one arm of clutch hub (C) to one clutch shoe.
3. Install other two clutch shoes on two arms as shown.

5-3 Installing clutch assembly

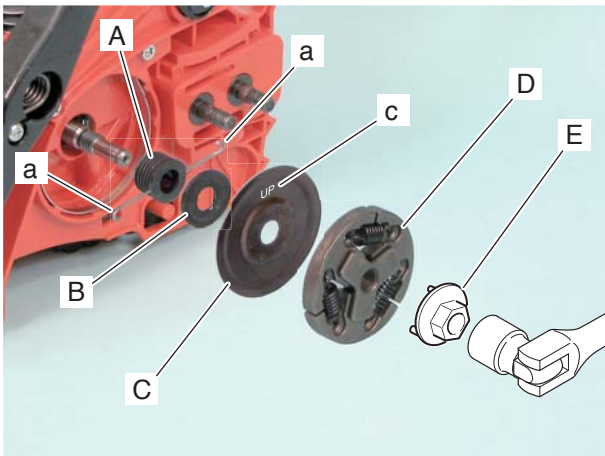

1. Install worm gear (A).
2. Install clutch plate (B), facing rounded edge side to worm gear.
3. Install clutch plate (C), facing the side with punch mark "UP" (c) to outside.
4. Install clutch assembly (D; Left-hand thread) to crankshaft turning counterclockwise by hand until it can not be turned further.

NOTE: If starter assembly is installed, untie temporary knot holding starter grip (tied in the first NOTE of "5-1 Inspecting clutch parts"). While holding starter grip, turn clutch assembly counterclockwise until it cannot rotate further (piston touches piston stopper).

5. Tighten clutch assembly with clutch tool 897505-16133 (E).

5-3 Installing clutch assembly (Continued)

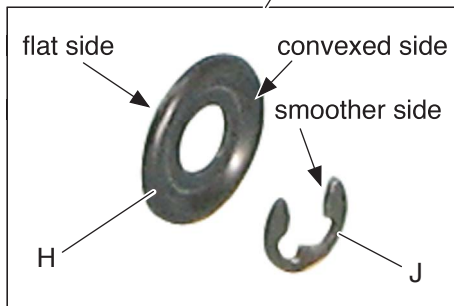
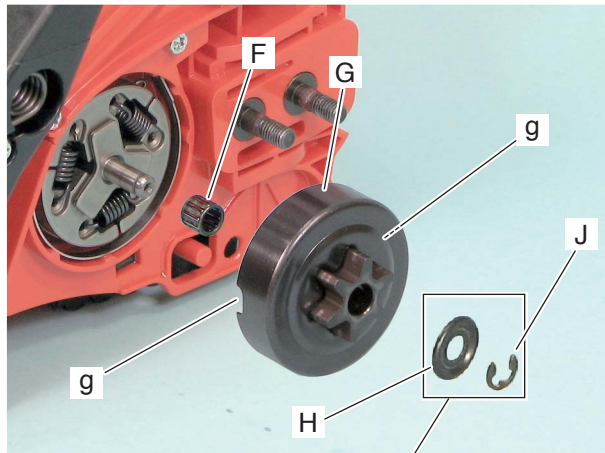

6. Apply lithium-based grease to needle bearing (F). Install clutch drum (G) and needle bearing (F) on crankshaft, placing the hands (a; see previous page) of worm gear (A) in cutouts (g) of clutch drum.

7. Install washer (H), facing flat side (not convexed side) to clutch drum (G).

8. Install new E-ring (J), facing rounded edge side to washer (H). Use a new E-ring every time E-ring is removed.

9. Remove piston stopper and reinstall all removed parts.

6 CHAIN BRAKE SYSTEM

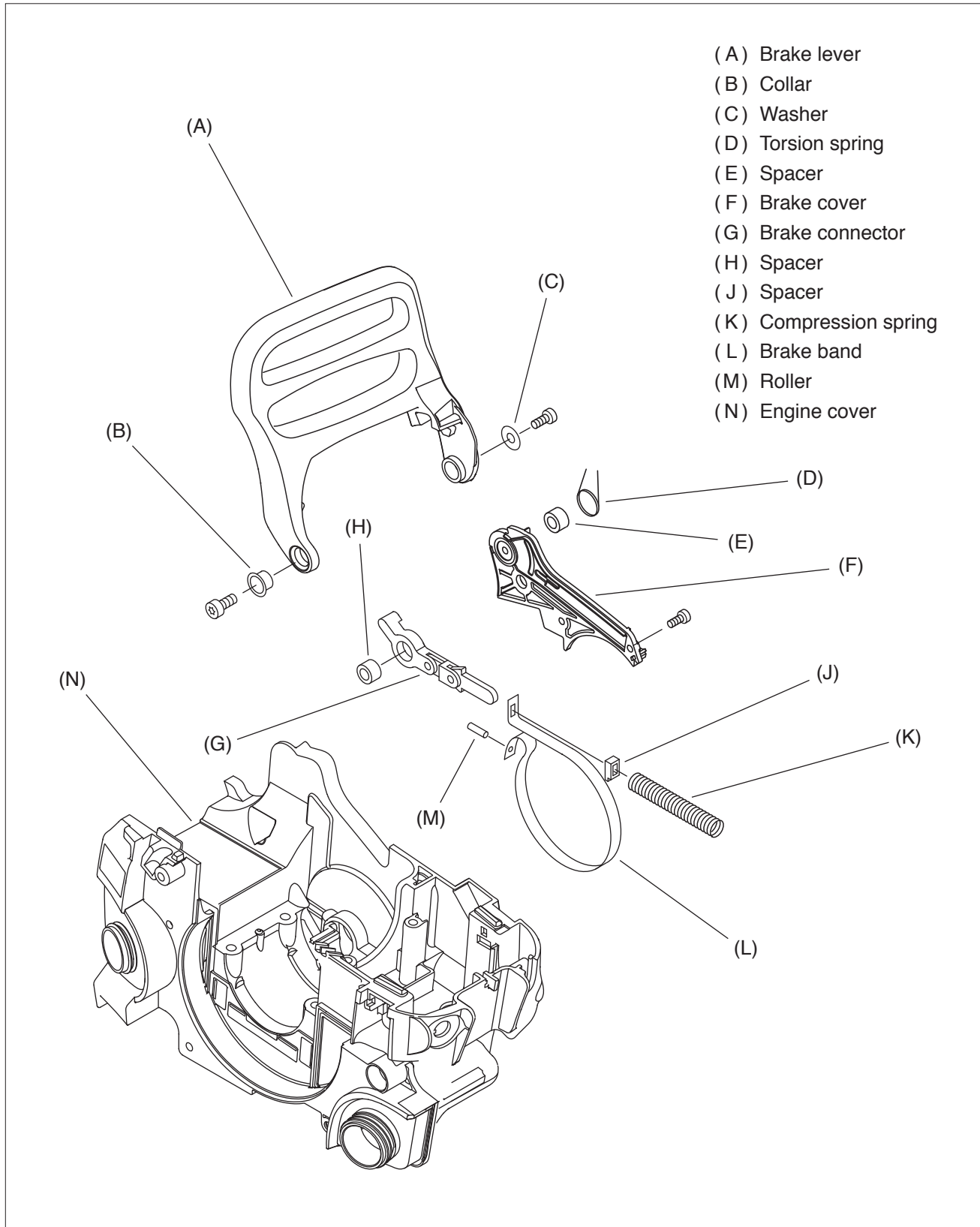

6-1 Disassembling chain brake

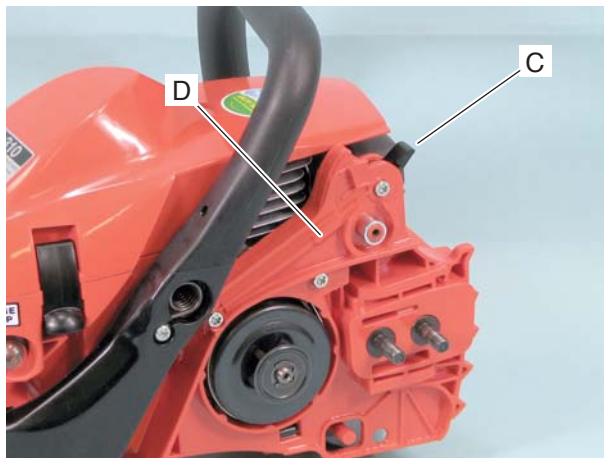
**WARNING**  **DANGER**

Wear eye protection and safety gloves when disassembling or assembling chain brake to protect eye and hand from injury.

1. Move brake lever (A) to chain brake engaging position.
2. Remove sprocket guard (B) and brake lever.

NOTE: Make sure that lever (C) is in engaging position before removing brake cover (D), otherwise compression spring may jump out.

3. Loosen three screws securing brake cover (D) and remove brake cover.
4. Inspect all the brake parts for damage. Replace them as required.

6-2 Assembling brake parts

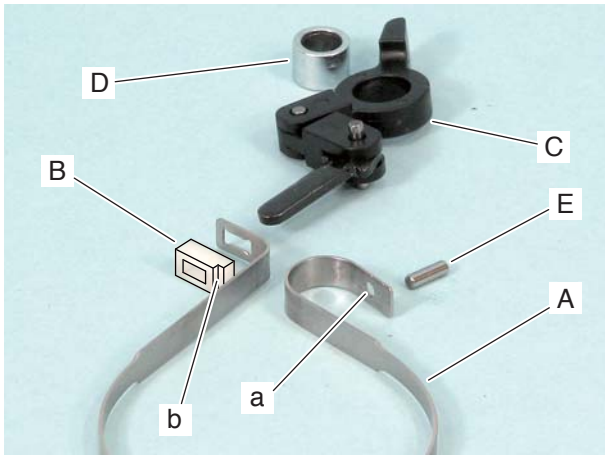

1. Set brake band (A) together with spacer (B), brake connector (C) and spacer (D), placing the notch (b) of spacer (B) as shown. Install roller (E) through brake band hole (a).

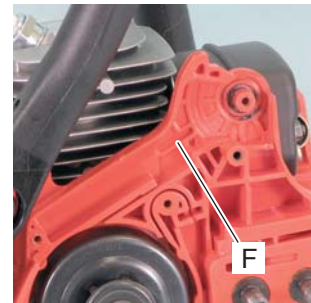
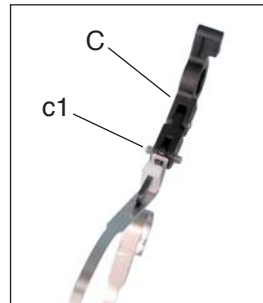

2. Install brake band and other parts (refer to the above 1.) on engine cover as shown in the left picture. Make sure the pin (c1) of brake connector (C) is engaging with the groove (F) of engine cover.

3. Slide in compression spring (G) to the end (c2) of brake connector as shown.

4. Push compression spring (G) with longnose pliers etc. and install compression spring in engine cover as shown in the below picture.

5. Apply molybdenum grease on entire compression spring and other friction parts.

6. Reinstall brake cover and other parts.



7 SAW CHAIN LUBRICATION SYSTEM

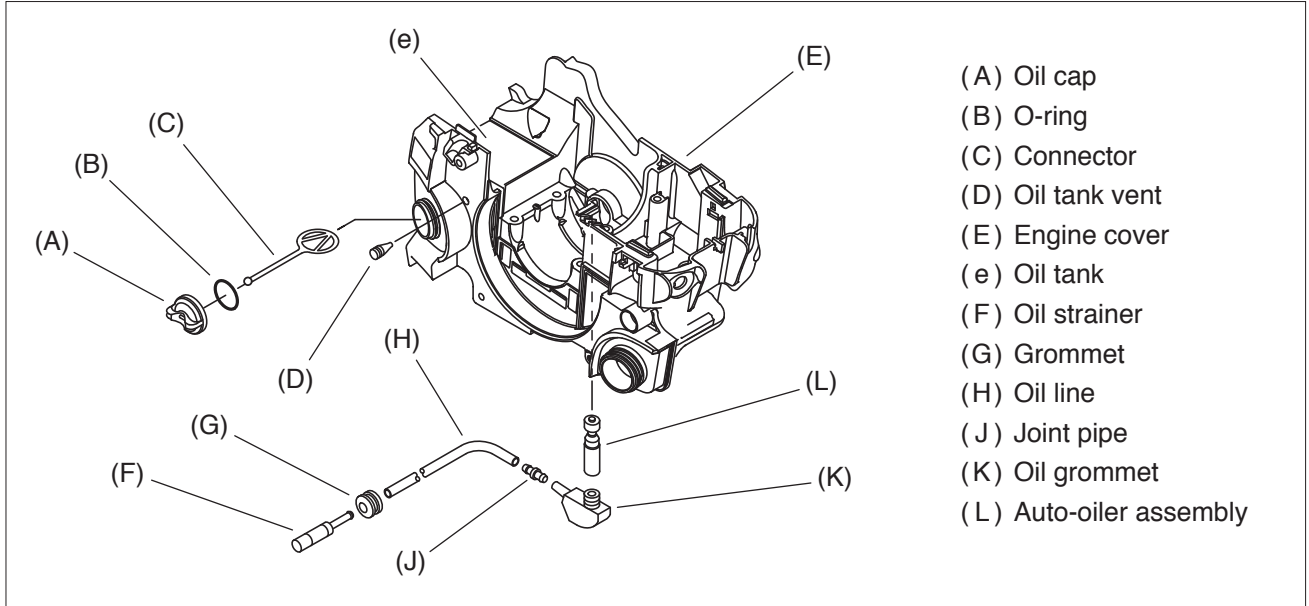

7-1 Inspecting oil cap and strainer

1. Remove oil cap.
2. Inspect oil cap for cracks and O-ring (A) for cuts or damage. Replace worn or damaged parts as required.
3. Pull oil strainer (B) from oil tank using a wire hook (C).
4. Remove oil strainer (B) from oil line (D) and clean oil strainer in suitable solvent, or replace if damaged.

7-2 Inspecting oil tank vent

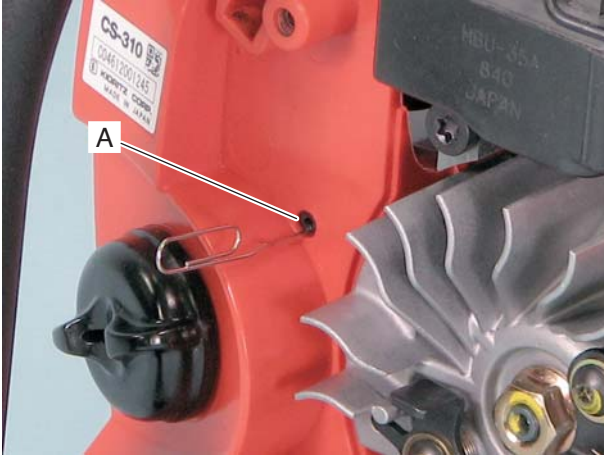

NOTE: Oil tank vent prevents a vacuum from forming in oil tank when chain oil in the tank is consumed.

1. Remove starter assembly.
2. Remove oil tank vent (A) using paper clip and clean it.

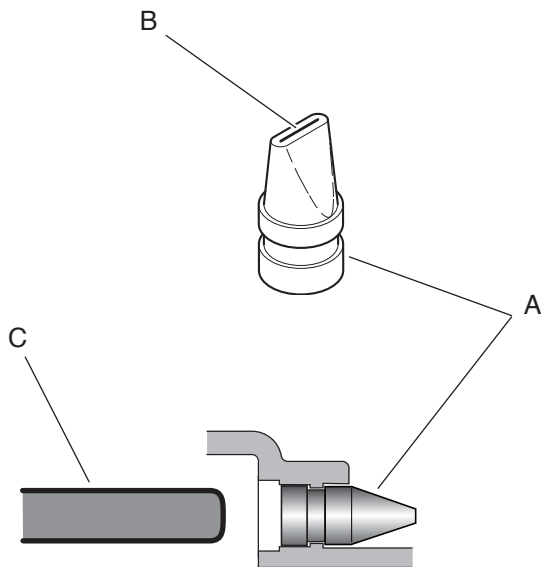

3. Check that oil tank vent lips (B) are not hard or deformed. Replace as required.

4. Install oil tank vent (A) using suitable tool (C) as shown.

7-3 Inspecting oil line

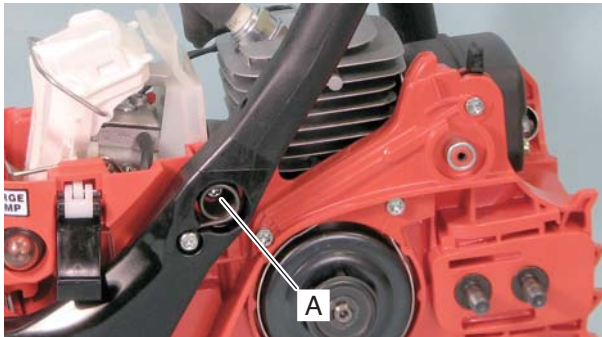

1. Remove starter assembly.
2. Remove screw (A).

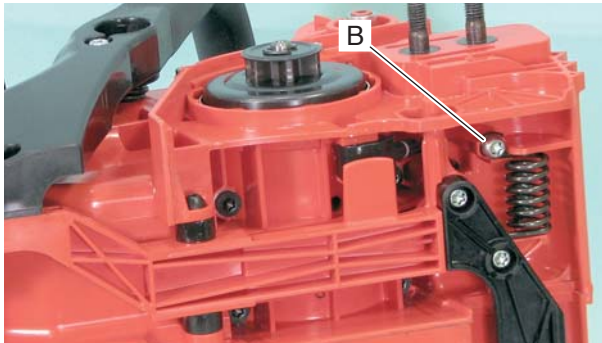

3. Remove screw (B) of unit bottom.

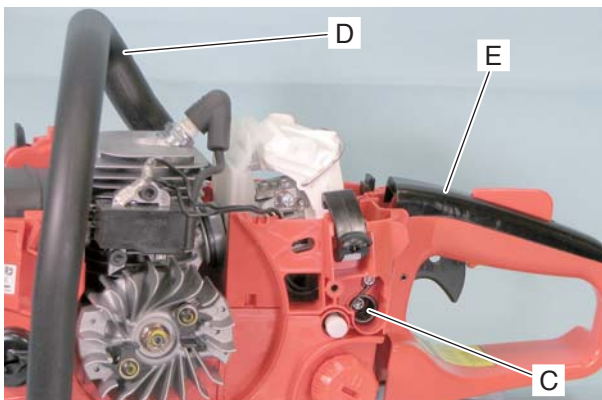

4. Remove screw (C).
5. Remove front handle (D) and rear handle (E) from engine unit.

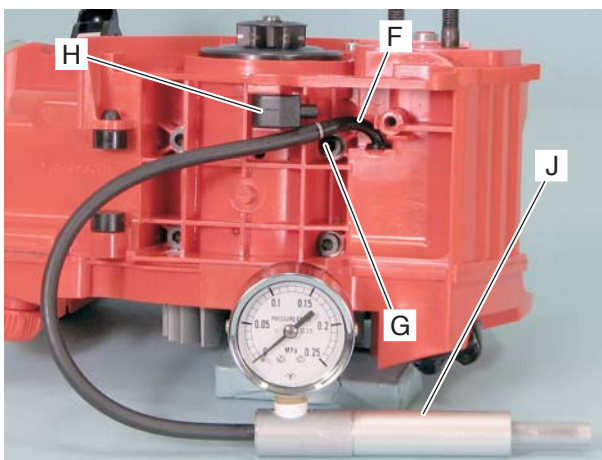

6. Disconnect oil line (F) with joint pipe (G), from oil grommet (H).
7. Connect pressure tester 897803-30133 (J) to joint pipe (G) as shown.

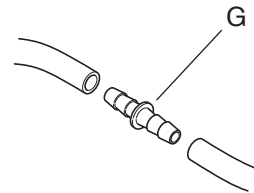

8. Tighten oil cap and apply pressure approx. 9.8 kPa (0.1kgf/cm²) (1.4psi).
9. Pressure should not drop. If the pressure drops, leakage may occur at oil cap, oil cap O-ring, mating surface of oil tank, oil line, grommet, or oil tank vent. Inspect them and replace defective part(s) with new parts as required.

7-4 Replacing oil line and grommet

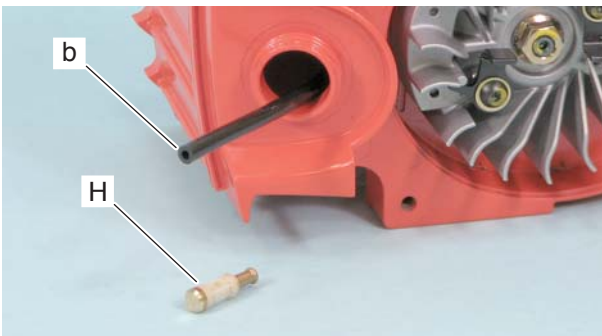
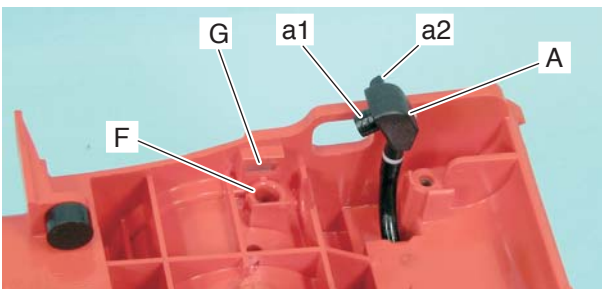
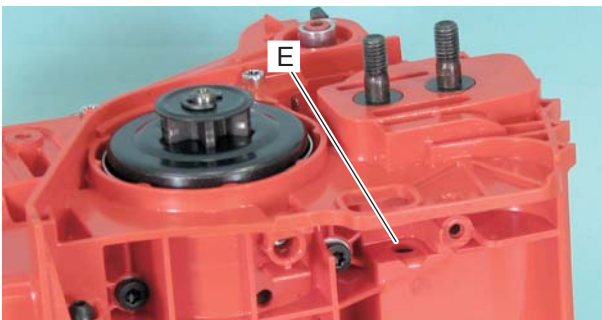
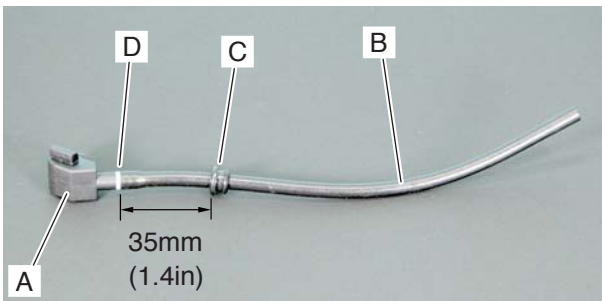
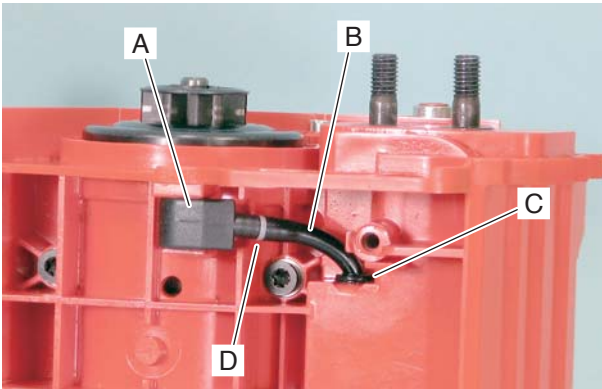

1. Pull out oil strainer from oil tank (Refer to “7-1 Inspecting oil cap and strainer”) and remove oil strainer from oil line.

2. Remove oil grommet (A) from engine cover.

3. Pull out oil line (B) from engine cover, together with grommet (C), joint pipe (D) and oil grommet (A).

4. Insert new oil line (B) to new grommet (C).

5. Set new joint pipe (D) and new oil grommet (A) as shown.

6. Assemble grommet (C) in grommet hole (E) of engine cover.

7. Assemble oil grommet (A) on engine cover.

NOTE: In order to assemble oil grommet easily, insert oil outlet (a1) in auto-oiler hole (F). Then push tab (a2) into square hole (G).

8. Pull out the other end (b) of oil line as shown.

9. Install oil strainer (H) to the other end (b) of oil line.

10. Put oil strainer and oil line in oil tank. Make sure oil strainer can move freely in oil tank.

NOTE: If oil strainer cannot move freely in oil tank, chain oil may not be supplied properly.

7-5 Replacing auto-oiler assembly

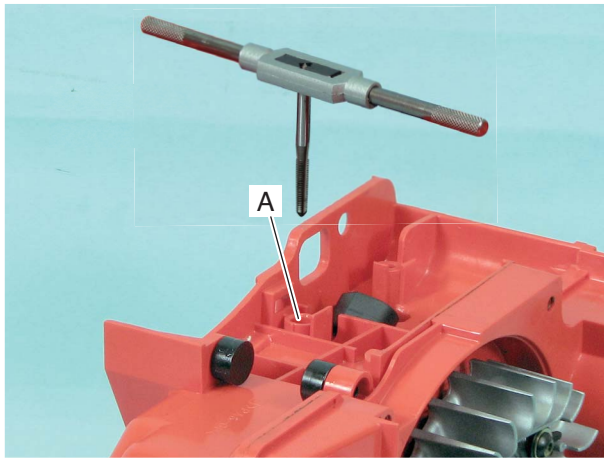

1. Tap 5-mm (M5 - Pitch 0.8mm) thread in the bore of auto-oiler (A).

2. Use auto-oiler puller Y089-000130 to remove auto-oiler.

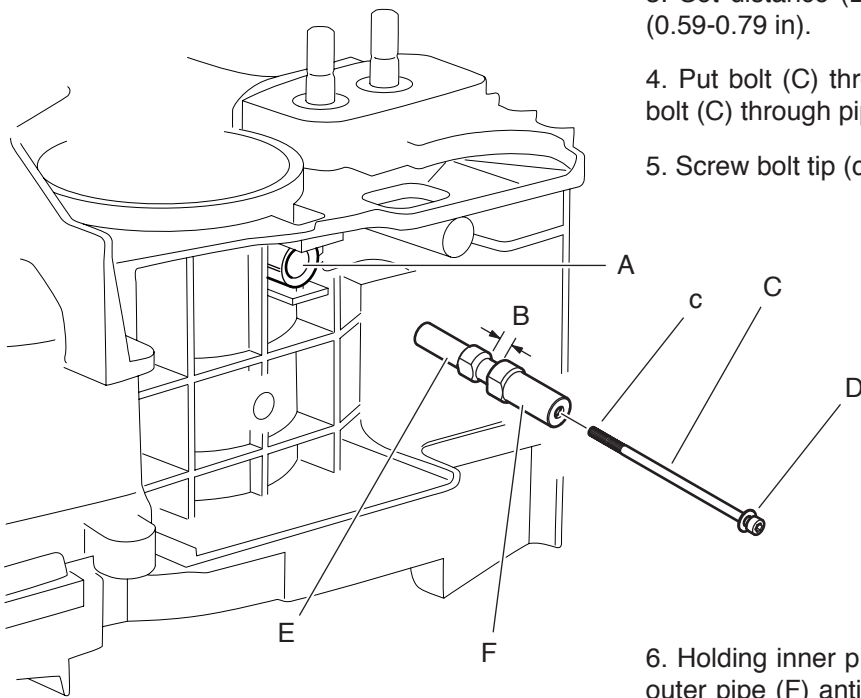
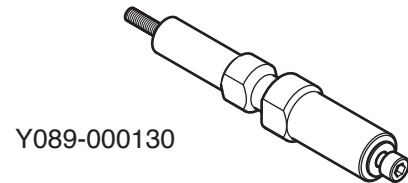

3. Set distance (B) of Y089-000130 to 15-20 mm (0.59-0.79 in).

4. Put bolt (C) through washer (D) as shown. Put bolt (C) through pipes (E) and (F).

5. Screw bolt tip (c) into the bore of Auto-oiler (A).

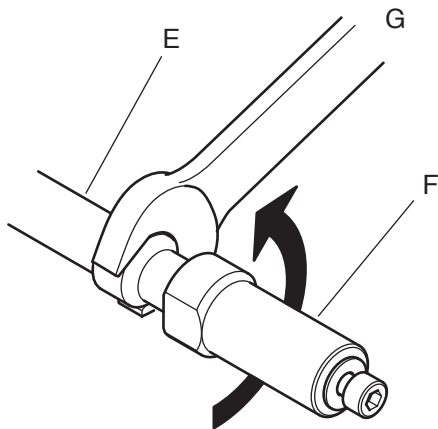

6. Holding inner pipe (E) with a wrench (G), rotate outer pipe (F) anticlockwise by another wrench, to pull out auto-oiler.



7-5 Replacing auto-oiler assembly (continued)

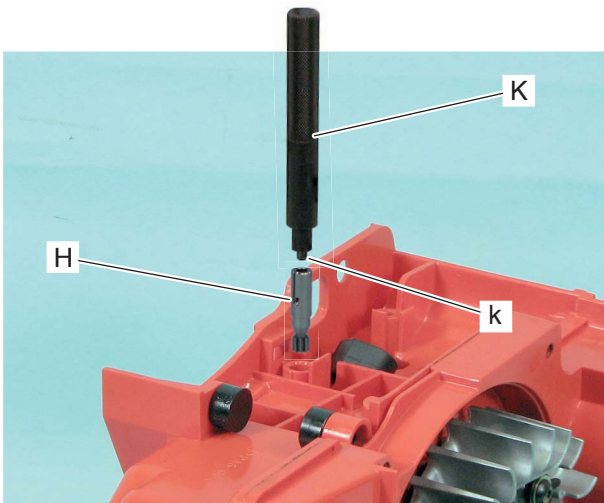

7. Set new auto-oiler (H) in engine cover, aligning oil groove (h) with the rib (J).

NOTE: If oil groove is not aligned with the rib, chain oil does not flow.

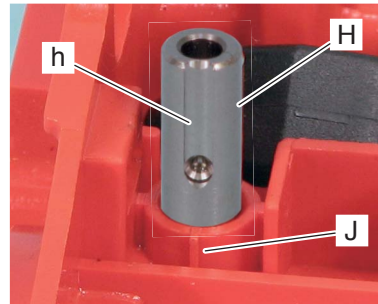

8. Set tip (k) of auto-oiler installer X646-000030 (K) in the bore of new auto-oiler (H).

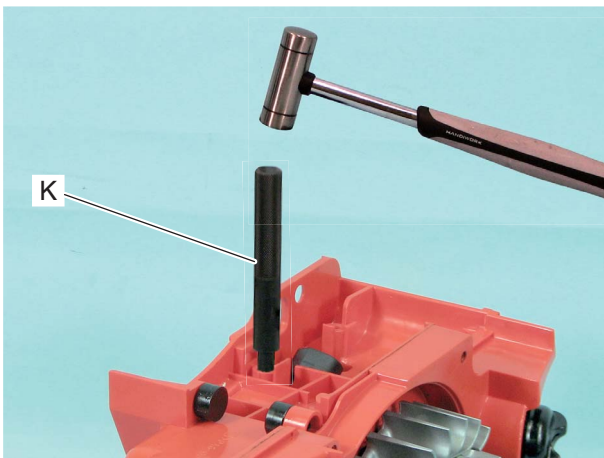

9. Tap auto-oiler installer (K) with small metal hammer, until it bottoms.



8 ENGINE

- (A) Cylinder (Upper crankcase)
- (B) Crankcase (Lower crankcase)
- (C) Crankshaft assembly
- (D) Ball bearing
- (E) Oil seal
- (F) Engine cover
- (G) Piston ring
- (H) Snap ring
- (J) Piston
- (K) Piston pin
- (L) Piston pin spacer
- (M) Intake bellows
- (N) Intake bellows retainer
- (O) Intake insulator

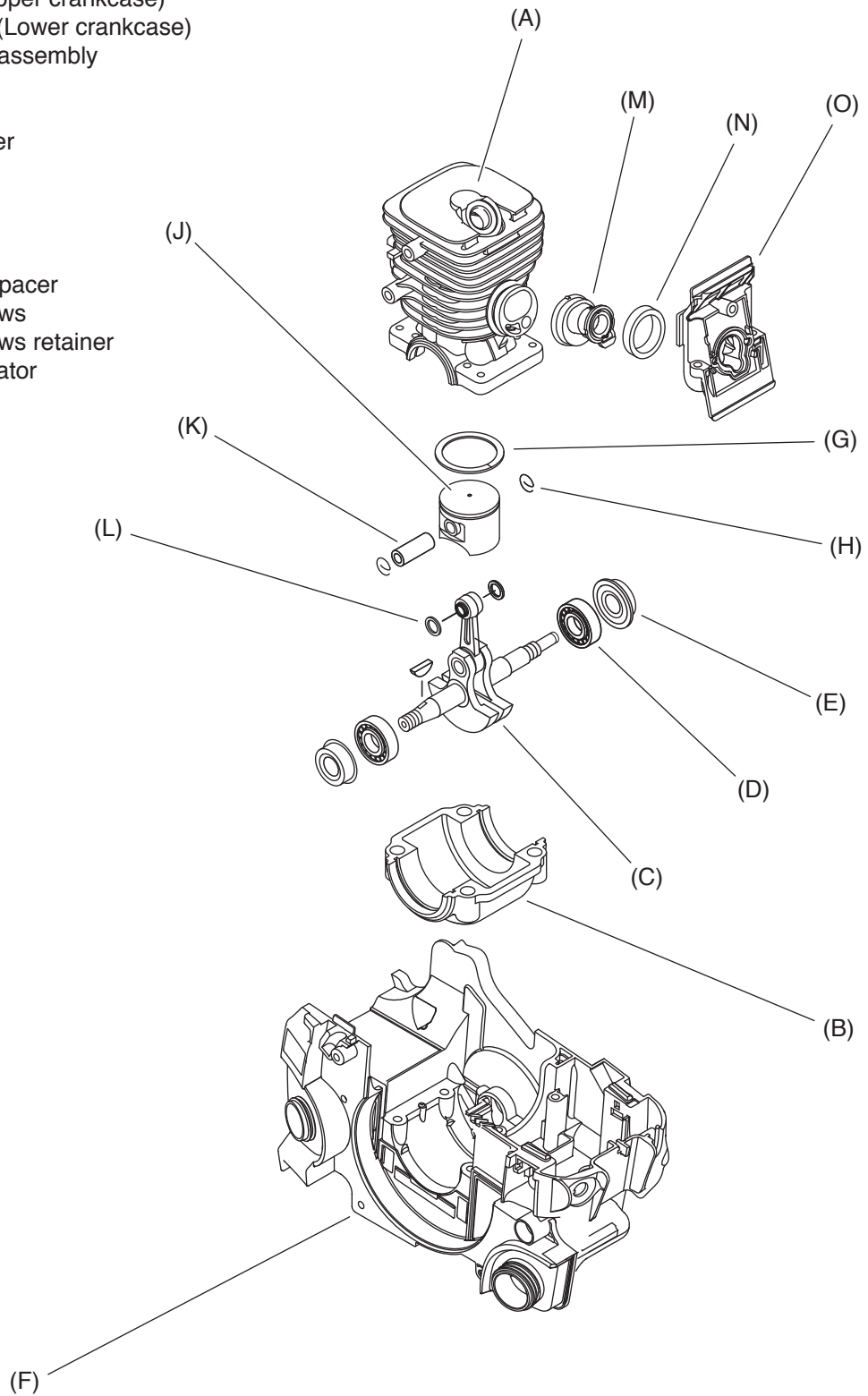

8-1 Testing cylinder compression

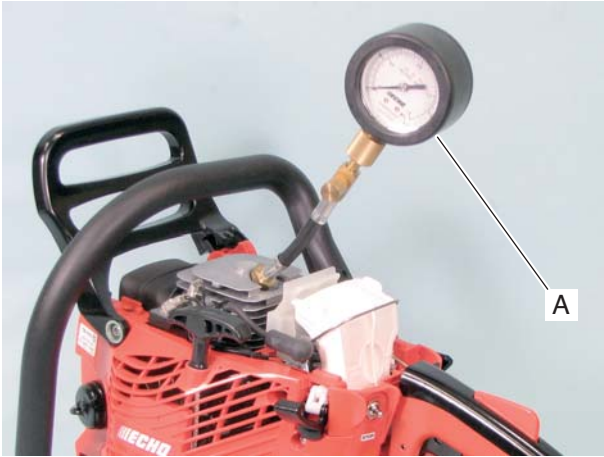

NOTE: Test cylinder compression when engine is cold.

1. Move ignition switch to STOP position. Then remove spark plug.

2. Install compression gauge 91037 (A) in spark plug hole and tighten by hand. Pull starter several times to stabilize reading on compression gauge.

3. If pressure is lower than approx. 75% of standard compression pressure (Refer to “1-2 Technical data”), inspect cylinder bore, piston and piston ring for wear or damage.

4. If pressure is more than approx. 125% of standard compression pressure, inspect cylinder combustion chamber and exhaust port, piston crown, and muffler for carbon deposits.

NOTE: Compression pressure varies with volume of compression gauge tip occupying cylinder combustion chamber. If gauge tip volume is considerably different from spark plug volume, it is recommended to measure and note compression pressure of brand-new engines as standard pressure in advance.

8-2 Cleaning cooling air passages



1. Remove cylinder cover. Remove starter assembly (Refer to “2-1 Disassembling starter assembly”).

WARNING  **DANGER**

Always wear eye protection when using compressed air for cleaning. Otherwise, eye damage can occur from flying particles.

2. Inspect cylinder cooling fins (A) for blockage with dirt and/or saw dust. Clean them with wooden or plastic stick or compressed air as required.

3. Install all removed parts.

8-3 Inspecting muffler and exhaust port



1. Remove cylinder cover.
2. Remove muffler with muffler gasket.
3. Inspect cylinder exhaust port and clean the port using wooden or plastic stick if carbon is found.

NOTE: When cleaning exhaust port, always position piston at Top Dead Center (TDC) to prevent carbon from entering cylinder. Do not use metal tool, and be careful not to scratch piston or cylinder.

NOTE: Replace muffler gasket with new one when removing muffler.

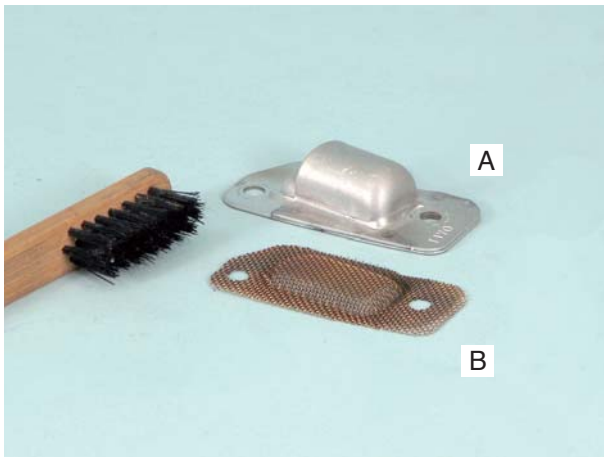

4. Remove muffler lid (A) and spark arrestor screen (B) from muffler.
5. Remove carbon deposits from spark arrestor screen and muffler lid. If screen has heavy deposits, replace with new one.
6. Reinstall spark arrestor screen and muffler lid to muffler.
7. Reinstall muffler with new muffler gasket.

8-4 Testing crankcase and cylinder seal

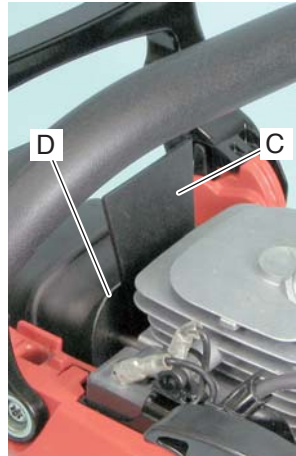
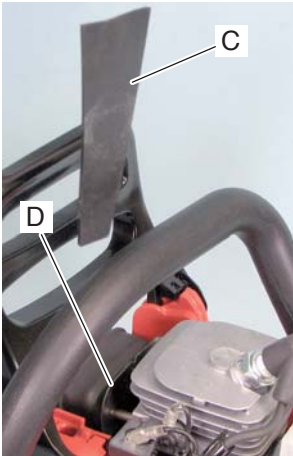

1. Remove cylinder cover, air filter and cleaner case.

2. Remove carburetor from the unit.

3. To seal intake port, install pressure rubber plug 897826-16131 (A) between intake bellows and carburetor, using carburetor screws (B). Tighten screws (B).

4. Loosen 2 nuts of muffler bolts. To seal exhaust port, insert pressure rubber plug 91041 (C) between cylinder exhaust port and muffler gasket (D), until it bottoms.

5. Tighten nuts of muffler bolts.

6. Remove spark plug and install pressure connector 897835-16131 (E) to spark plug hole.

7. Connect pressure tester 91024 (F) to pressure connector (E).

8. Apply pressure approx. 9.8 kPa (0.1 kgf/cm²) (1.4 psi) by pressure tester.

NOTE: Do not exceed 30 kPa (0.3 kgf/cm²) (4.3 psi). Otherwise, damage to oil seal may occur.

9. If the reading drops, leakage may occur.

10. Leakage may occur from crankcase seam or oil seal. Use soapy water to locate leakage.

11. Then, apply negative pressure approx. 9.8 kPa (0.1 kgf/cm²) (1.4 psi) by pressure tester.

12. If the reading drops, leakage may occur from oil seal. Inspect oil seal for damage or wear.

13. Remove pressure tester (F) from pressure connector (E). Remove pressure rubber plugs (A) and (C) from intake bellows and exhaust port.

8-5 Removing engine block

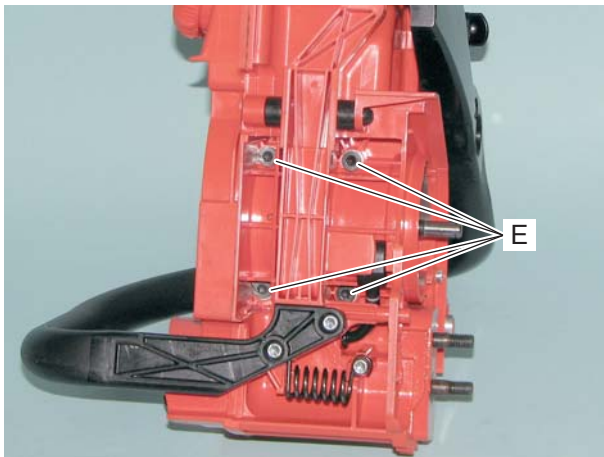
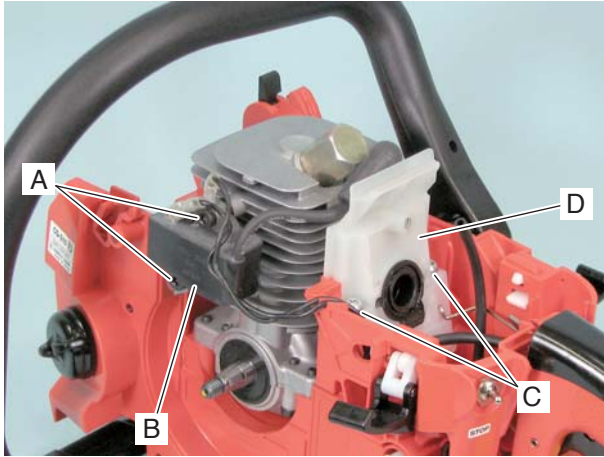

1. Remove cylinder cover, sprocket guard, brake lever and starter assembly (Refer to “2-1 Disassembling starter assembly”).
2. Remove air filter, cleaner case and carburetor.
3. Remove flywheel (Refer to “3-10 Inspecting flywheel and key”).
4. Remove clutch assembly and worm gear (Refer to “5-1 Inspecting clutch parts”).
5. Remove muffler with muffler gasket.
6. Remove two bolts (A) and remove ignition coil (B).
7. Remove two bolts (C) of intake insulator (D).
8. Remove 4 bolts (E) from bottom of the unit.
9. Pull out engine block, together with intake insulator (D).

8-6 Inspecting cylinder

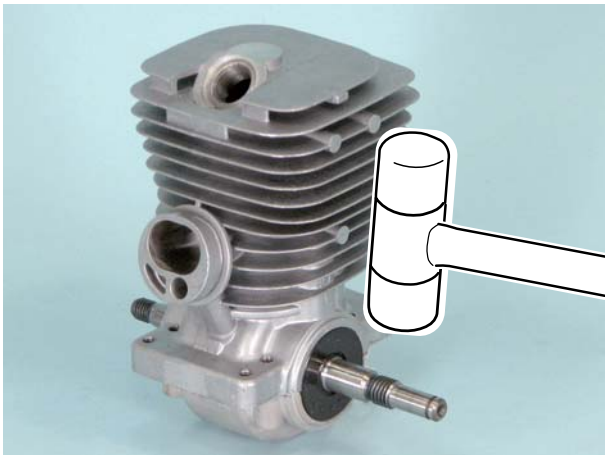
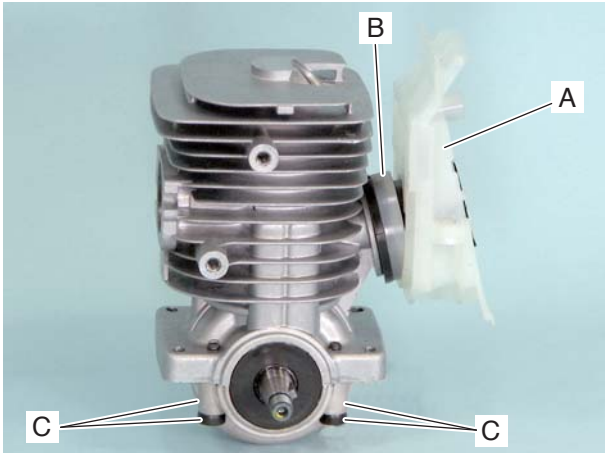

1. Remove intake bellows from cylinder, together with intake insulator (A) and intake bellows retainer (B).

2. Remove 4 bolts (C) securing crankcase.

3. Gently tap both crankshaft ends using plastic mallet to remove lower crankcase with crankshaft and piston assembly.

4. Inspect cylinder combustion chamber and clean with a plastic or wooden scraper if carbon is found.

NOTE: Do not use metal tools, or damage to cylinder wall may result.

5. Inspect cylinder wall and replace with new one if plating is worn, peeled away, scored or exposing cylinder base metal.

8-7 Inspecting piston and piston ring

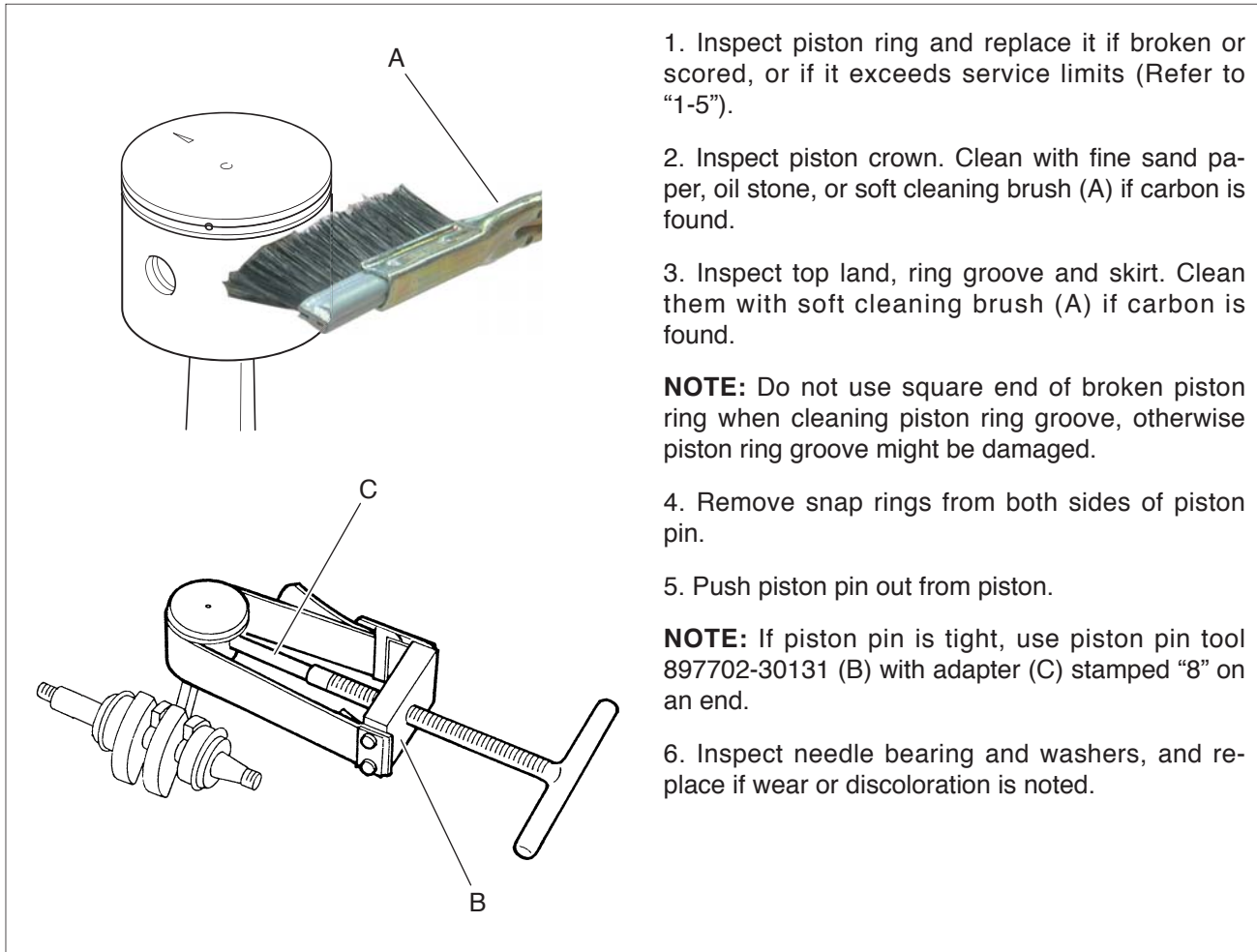

1. Inspect piston ring and replace it if broken or scored, or if it exceeds service limits (Refer to "1-5").

2. Inspect piston crown. Clean with fine sand paper, oil stone, or soft cleaning brush (A) if carbon is found.

3. Inspect top land, ring groove and skirt. Clean them with soft cleaning brush (A) if carbon is found.

NOTE: Do not use square end of broken piston ring when cleaning piston ring groove, otherwise piston ring groove might be damaged.

4. Remove snap rings from both sides of piston pin.

5. Push piston pin out from piston.

NOTE: If piston pin is tight, use piston pin tool 897702-30131 (B) with adapter (C) stamped "8" on an end.

6. Inspect needle bearing and washers, and replace if wear or discoloration is noted.

8-8 Inspecting crankcase and crankshaft

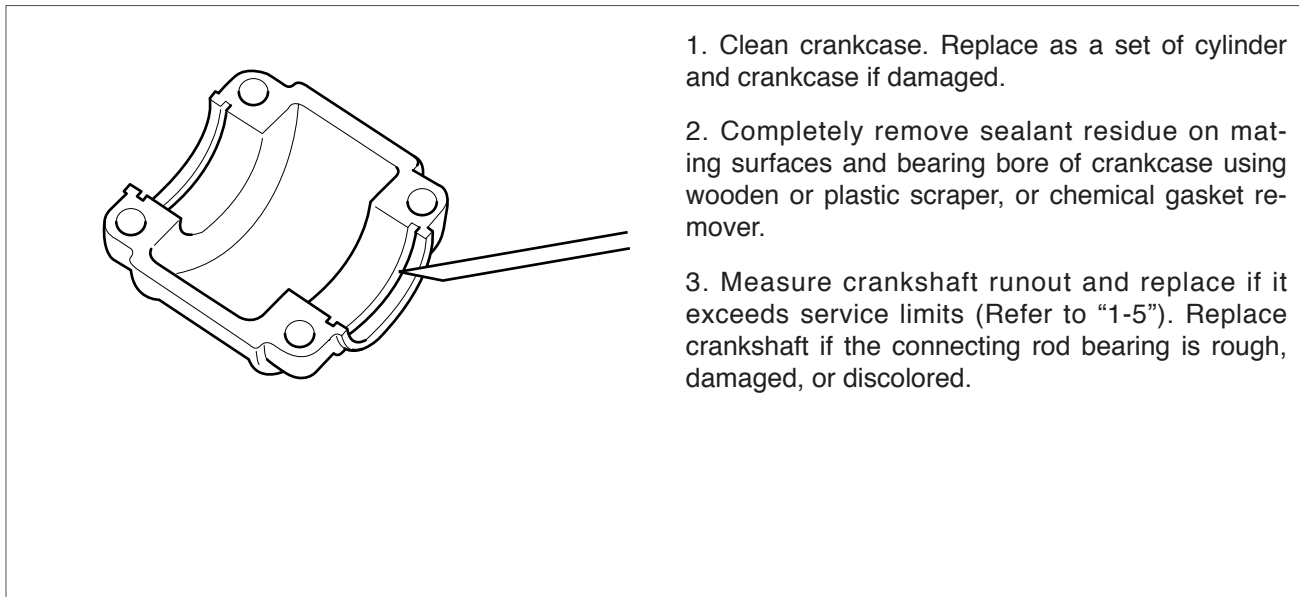

1. Clean crankcase. Replace as a set of cylinder and crankcase if damaged.

2. Completely remove sealant residue on mating surfaces and bearing bore of crankcase using wooden or plastic scraper, or chemical gasket remover.

3. Measure crankshaft runout and replace if it exceeds service limits (Refer to "1-5"). Replace crankshaft if the connecting rod bearing is rough, damaged, or discolored.

8-9 Replacing oil seal and ball bearing

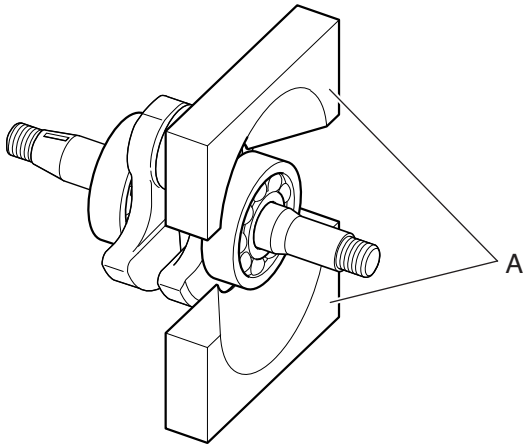

1. Check oil seal(s) and replace if defective.

2. Check ball bearing(s) for smooth rotation. If not, remove ball bearing(s) using bearing wedge (A) 897701-02830.

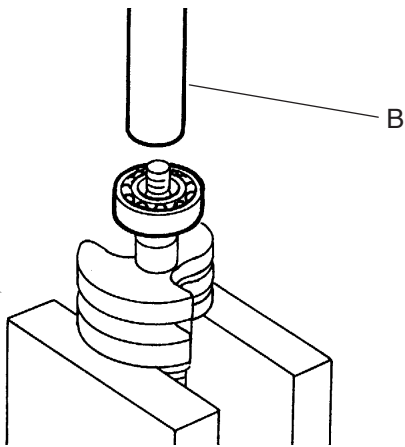

3. Install new ball bearing(s) onto crankshaft using bearing/seal tool 897726-21430 (B). Bearing should be completely seated against crankshaft counterweights.

NOTE: Preheat ball bearing using heating gun, heat lamp, or suitable heater for easier installation.

4. Install oil seals onto both ends of crankshaft insuring proper direction of oil seal.

8-10 Installing piston and piston ring

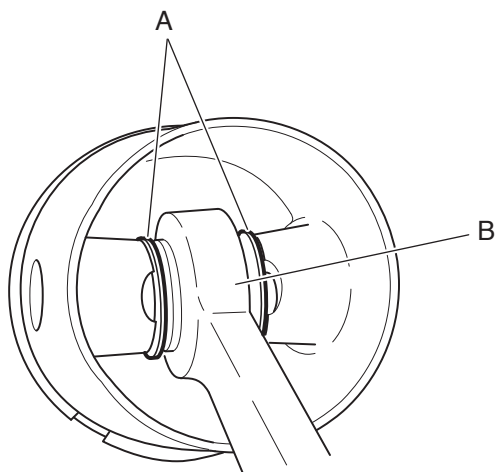

1. Set piston pin spacers (A) on small end of connecting rod (B) as shown.

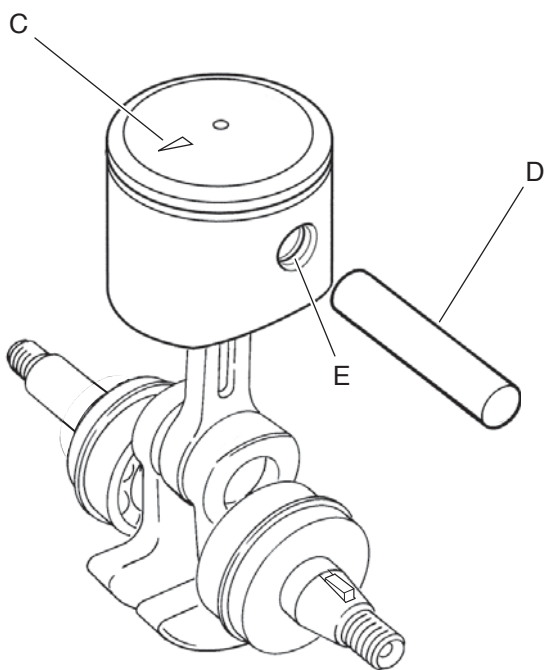

NOTE: Place piston over connecting rod with piston arrow mark (C) pointing as shown.

2. Insert pin guide tool (D) stamped "8", through piston, with piston pin spacers set at step 1.

3. Insert piston pin in piston, pushing out pin guide tool until the pin end comes up to snap ring groove (E).

NOTE: If piston pin is tight, use piston pin tool 897702-30131 with pusher adapter stamped "8".

4. Install new snap rings on both end of piston pin. Make sure that they are properly seated in snap ring grooves.

NOTE: Always use new snap rings.

5. Install piston ring on piston.

8-11 Assembling piston into cylinder

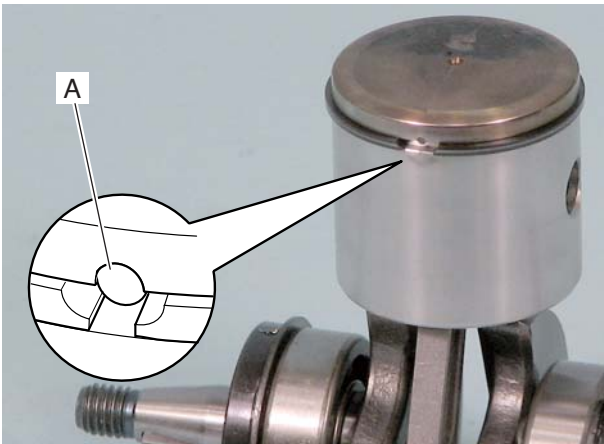

1. Apply 2-stroke oil on cylinder walls, oil seal grooves, piston ring, ball bearing, and both sides of con-rod.

2. Position end gap of piston ring with locating pin (A).

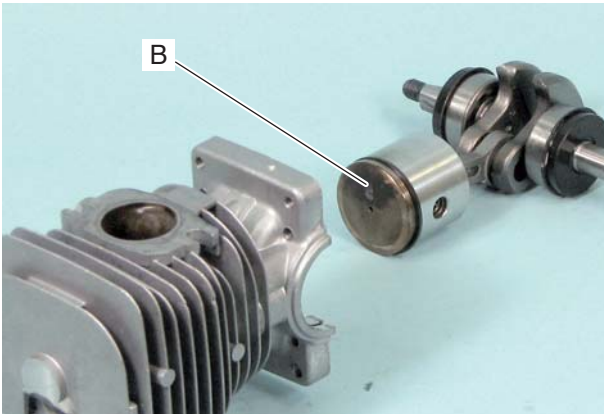

3. Install piston in cylinder with arrow (B) pointing to muffler side.

NOTE: When installing piston in cylinder, do not twist cylinder to avoid breakage of piston ring and scoring cylinder bore.

4. Make sure that rims of oil seal are properly seated in the grooves of cylinder (upper crankcase).

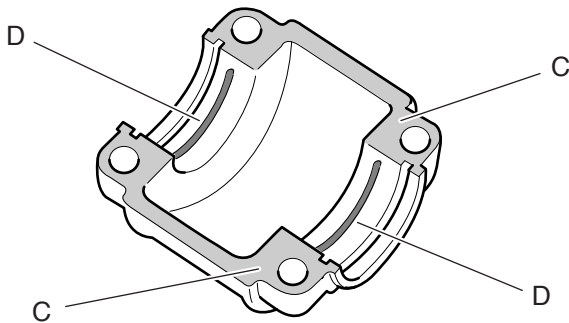

5. Apply liquid gasket (ThreeBond 1207D: Parts No. X686-000000, or equivalent) on seams (C) of lower crankcase.

6. Apply adhesive (Loctite #675 or equivalent) on bearing bores (D) of lower crankcase as shown.

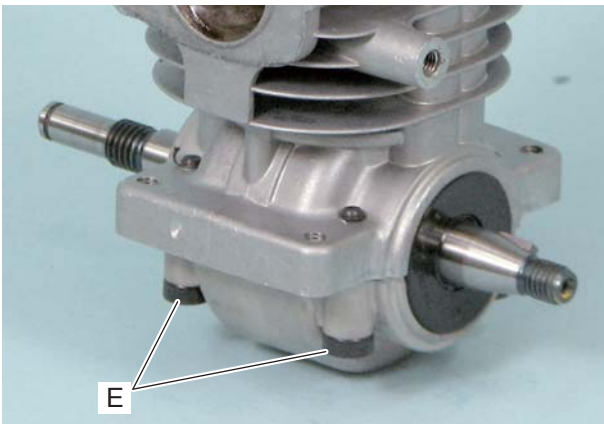

7. Set upper and lower crankcases as shown. Fasten 4 bolts (E).

8-12 Installing engine block

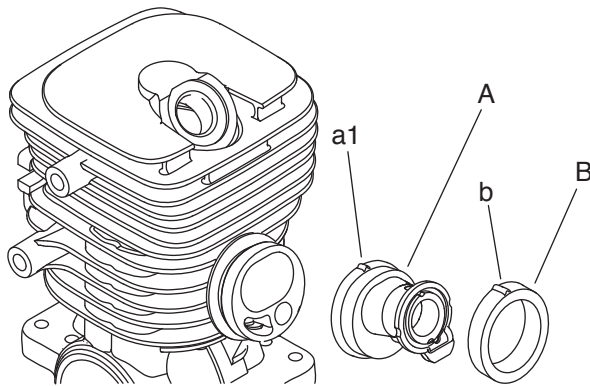

1. Assemble intake bellows (A) and intake bellows retainer (B) to cylinder, aligning locating marks (a1) and (b).

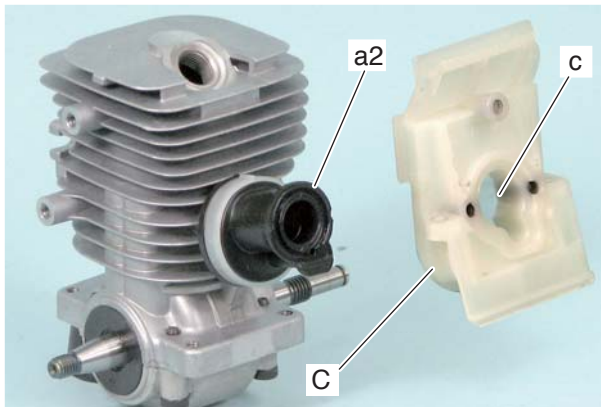

2. Install flange (a2) of intake bellows in the hole (c) of intake insulator (C).

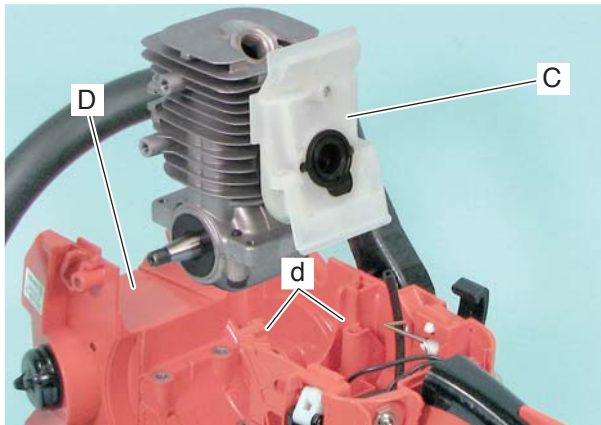

3. Mount engine block on engine cover (D) while installing intake insulator (C) into the grooves (d) of engine cover.

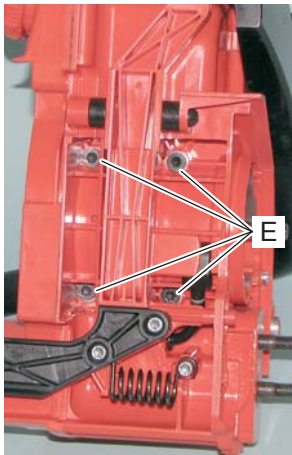

4. Tighten 4 bolts (E) at unit bottom to secure engine block to engine cover. Tighten 2 screws (F) of intake insulator. Install all other removed parts.

9 REAR HANDLE AND CONTROL SYSTEM

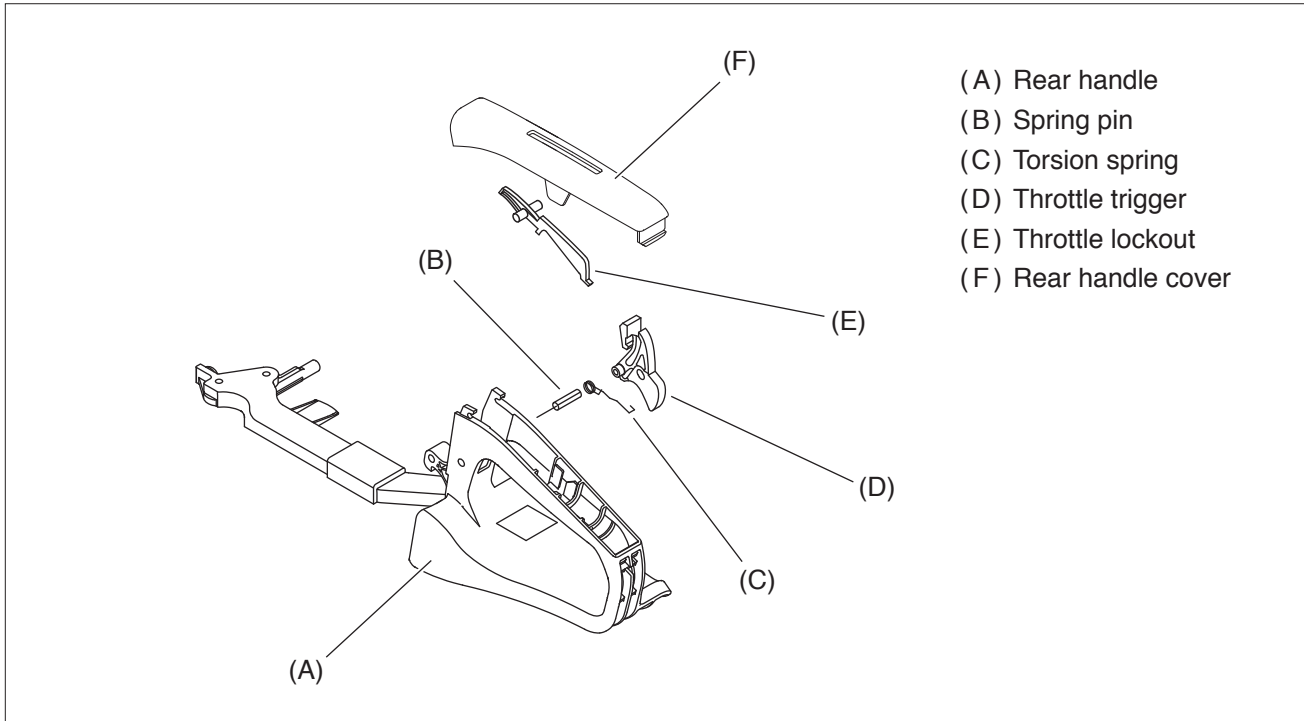

9-1 Replacing throttle trigger

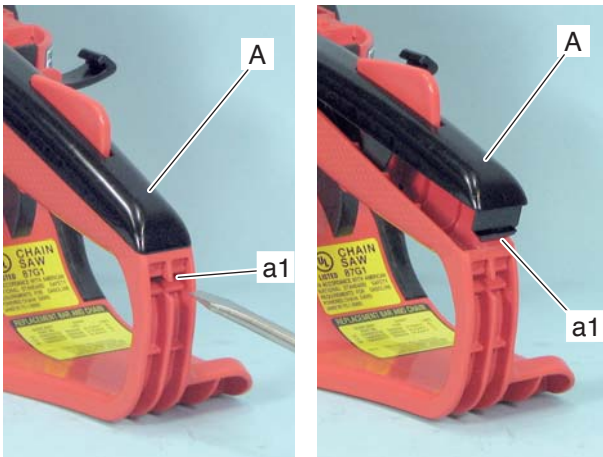

1. Push in hook (a1) of rear handle cover (A) and pry away rear handle cover from rear handle.

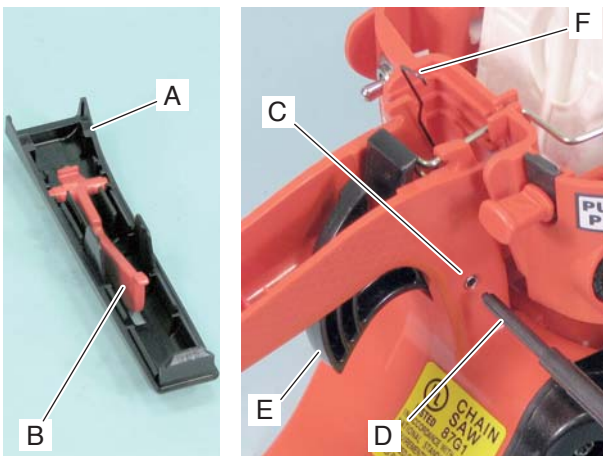

2. Inspect rear handle cover (A) and throttle lockout (B) for cracking or wear. If damaged, replace it as required.

3. Push out spring pin (C) from rear handle using spring pin tool 897724-01361 (D).

NOTE: Spring pin will stop before completely coming off from rear handle, because of effective length of spring pin tool.

4. Remove throttle trigger (E) together with torsion spring (F).

9-1 Replacing throttle trigger (continued)



5. Set torsion spring (F) on throttle trigger (E) as shown.



6. Install throttle trigger (E) with torsion spring (F) and insert spring pin (C) as follows.

1) Insert spring pin (C) in the hole of rear handle so that tip of spring pin does not protrude inside handle.

2) Hold throttle trigger (E) with torsion spring (F) in place, and insert spring pin tool 897724-01361 (D) from the other side of handle through the hole of throttle trigger.

3) Lightly tap in spring pin (C), pushing out spring pin tool (D).

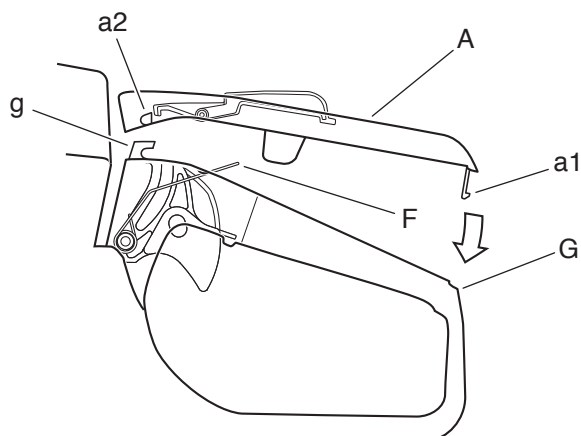

7. Hook the inside tab (a2) of rear handle cover (A) on the notch (g) of rear handle (G).

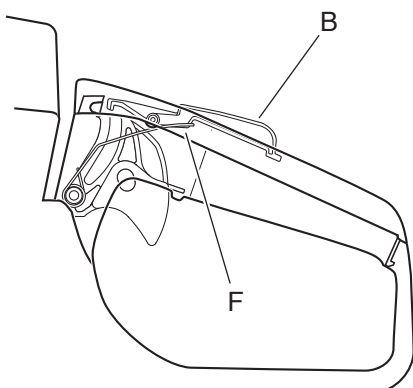

8. Push in hook (a1) and install rear handle cover (A) on rear handle (G), setting torsion spring (F) with throttle lockout (B) as shown.

9. Check throttle trigger and throttle lockout for correct movement.

9-2 Replacing cushions



1. Remove starter assembly from the unit (Refer to “2-1 Disassembling starter assembly”).

2. Remove front handle and rear handle from the unit (Refer to “7-3 Inspecting oil line”).

3. Inspect cushions for cracking or wear. If damaged, replace with new cushions as follows.

4. Remove cushion (A) with needlenose pliers from bottom of the unit.

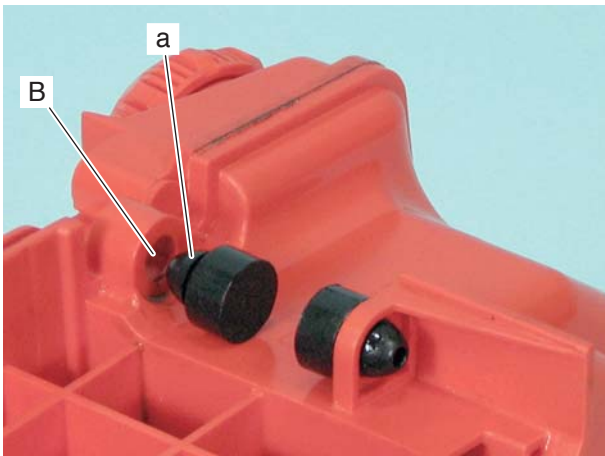

5. Apply lithium-based grease on outer surface (a) of cushion toe, then install cushion by pushing into the hole (B).

6. Reassemble front handle and rear handle to the unit. Reassemble all related parts.

10 GUIDE BAR MOUNTING SYSTEM

- (A) Sprocket guard
- (B) Tensioner screw
- (C) Chain tensioner
- (D) Collar
- (E) Bevel gear
- (F) Bevel gear

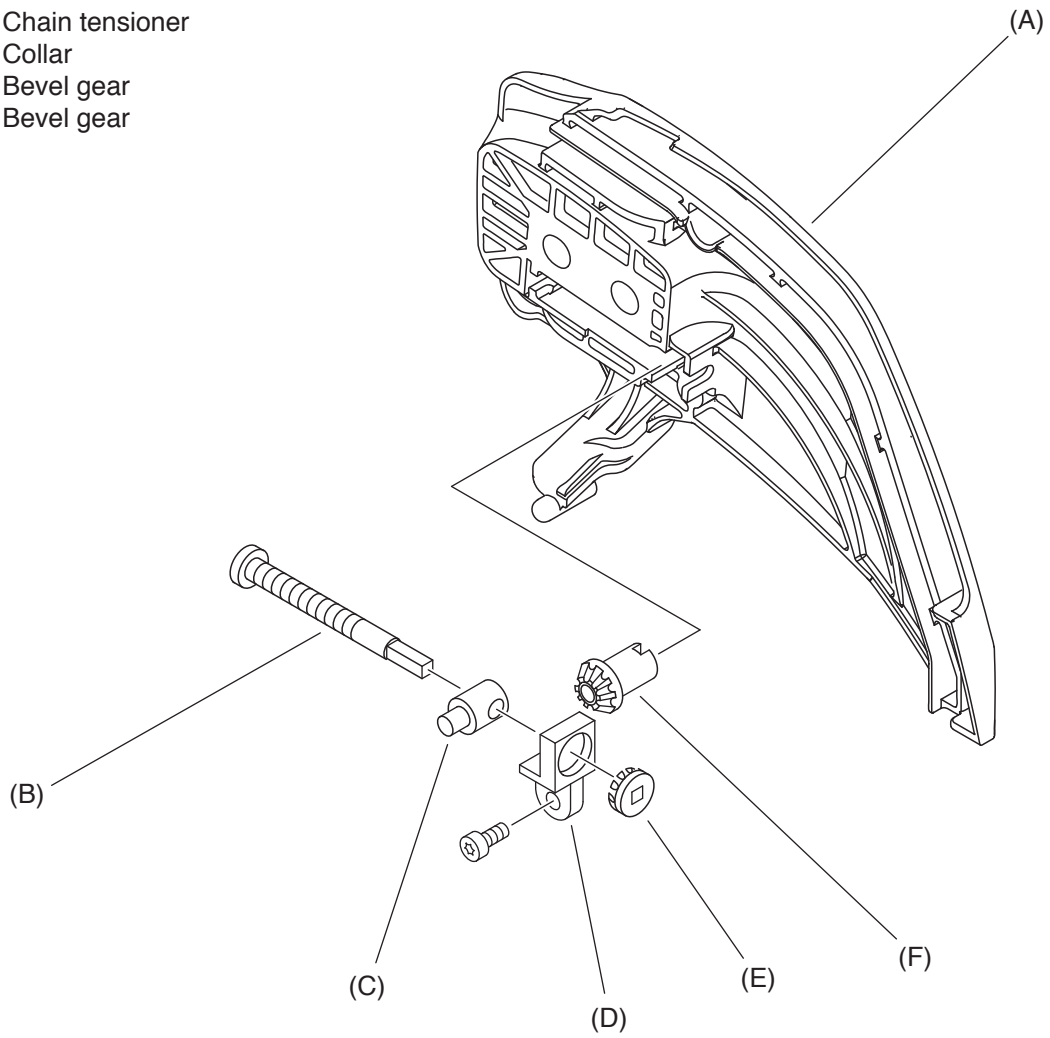

10-1 Replacing chain tensioner

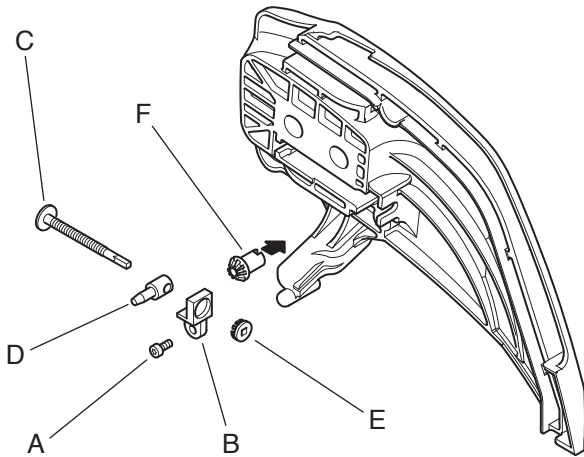

1. Remove bolt (A) from sprocket guard. Remove tensioner screw (C), chain tensioner (D), collar (B) and bevel gear (E). Remove bevel gear (F).

2. Inspect them for damage or wear. Replace as required.

3. Install bevel gear (F) into sprocket guard.

4. Screw chain tensioner (D) on tensioner screw (C).

5. Set bevel gear (E) in collar (B) and insert tensioner screw (C) with chain tensioner (D) in bevel gear (E) with collar (B).

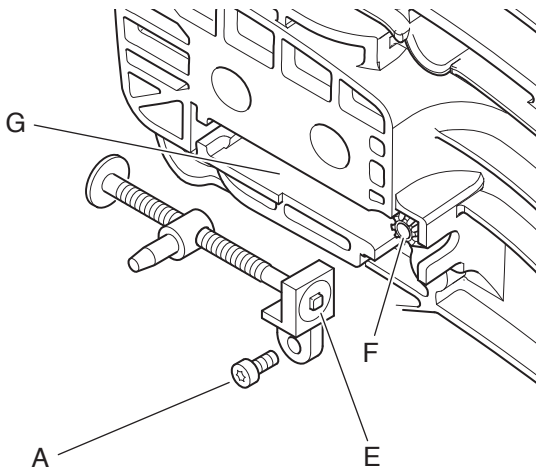

6. Install sub-assembled tensioner screw in slot (G) of sprocket guard, confirming engagement of bevel gear (E) and (F).

7. Reinstall bolt (A).

10-2 Replacing guide bar stud

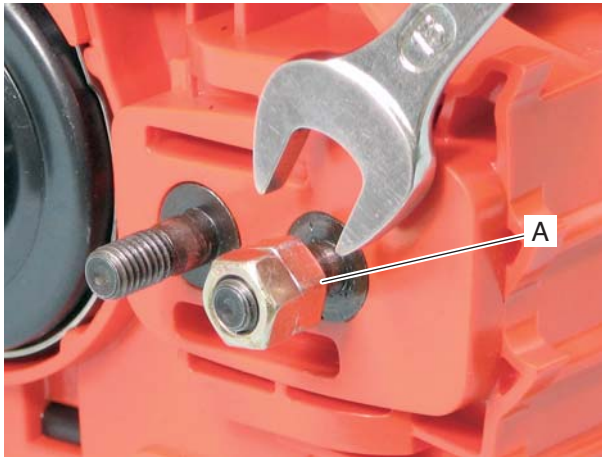

1. Install two nuts on defective stud and tighten them against each other.

2. Turn nut (A) counterclockwise to remove stud.

NOTE: If it is hard to remove or broken stud is too short for tightening two nuts, hold defective stud by vise and turn the chain saw body counterclockwise, or use a suitable stud remover.

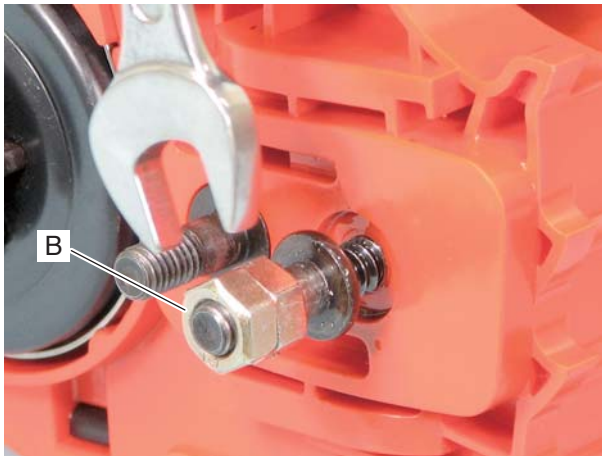

3. Install two nuts on new stud and tighten them against each other.

















































NOTE: Apply a small amount of thread locking sealant in the thread hole (locktite #675 or equivalent).

4. Turn nut (B) clockwise to install stud.

11 MAINTENANCE GUIDE

11-1 Troubleshooting guide

TROUBLE	
Engine does not crank.	01
Engine does not start.	02
Fuel leaks.	03
Idling is not stable.	04
Acceleration is poor.	05
Engine stalls at high speed.	06
Engine lacks power.	07
Engine seizure / overheat	08
Engine misfires.	09
Engine / others are extremely noisy.	10
Fuel consumption is excessive.	11
Vibration is excessive.	12
Engine does not stop.	13
Oiler does not function.	14
Saw chain does not cut well.	15

INSPECTING	REFERENCES	Inspecting  first.														
Starter system		15	14	13	12	11	10	09	08	07	06	05	04	03	02	01
Starter pawl / spring	2-4															
Starter drum / rope	2-2															
Rewind spring	2-3															
Ignition system		15	14	13	12	11	10	09	08	07	06	05	04	03	02	01
Sparks	3-2															
Spark plug	3-3															
Spark plug cap / coil	3-7															
Ignition switch	3-4															
Ignition coil	3-6, 3-8															
Pole shoe air gaps	3-9															
Flywheel	3-10															
Flywheel key	3-10															
Clutch system		15	14	13	12	11	10	09	08	07	06	05	04	03	02	01
Clutch shoes / spring / bearing	5-1 to 5-3															
Clutch drum	5-1, 5-3															
Sprocket	1-5, 5-1															
(Continued)																

11-2 Disassembly chart

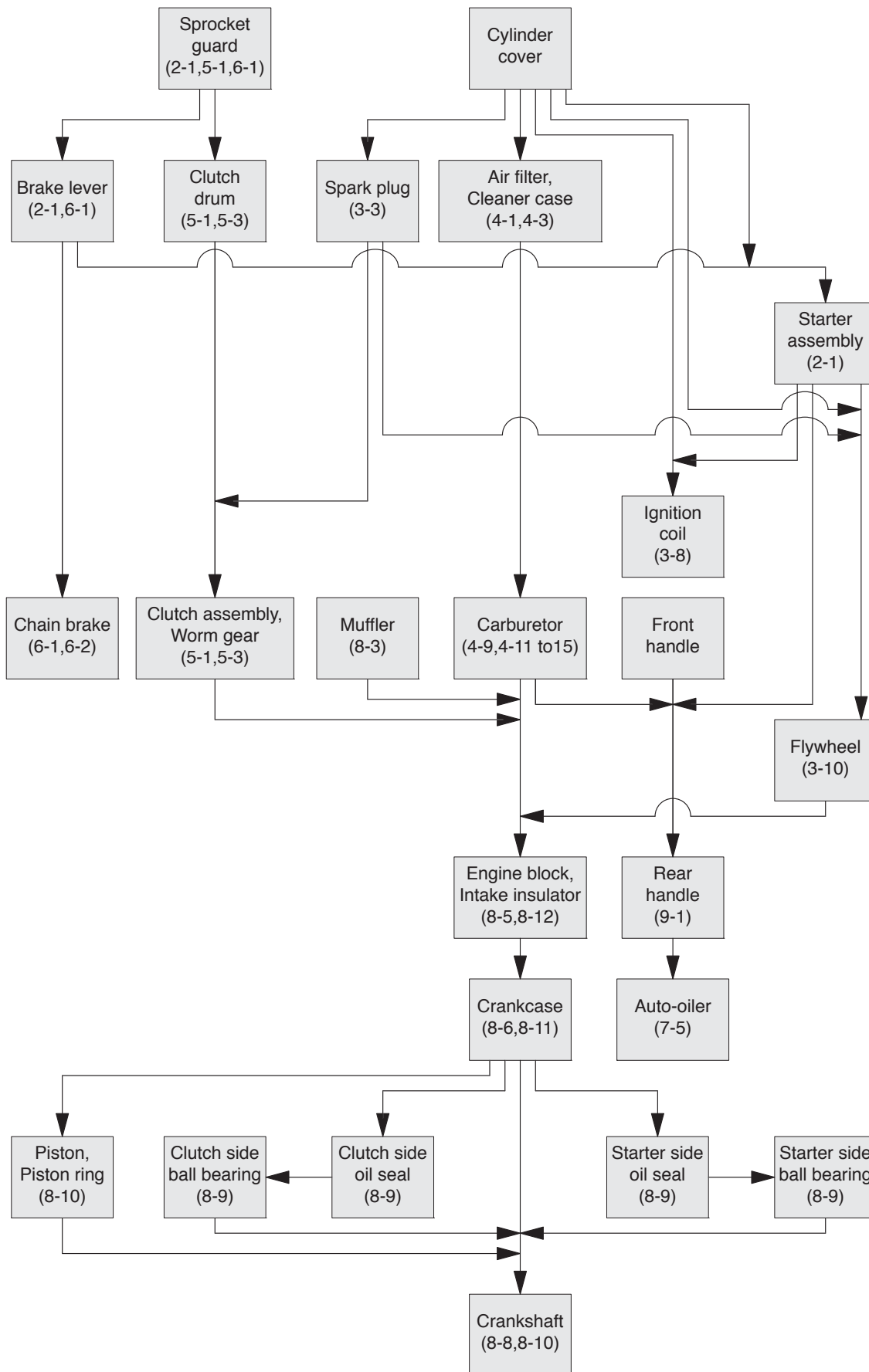

11-3 Service Intervals

Inspecting point	Service	Reference	Intervals		
			Daily	3 months or 100 hours	6 months or 300 hours
Screws and bolts *	Retighten / Replace			○	
Air filter	Clean	4-1	○		
	Inspect / Replace	4-1		○	
Carburetor	Inspect / Repair	4-9 to 4-15			○
Fuel leaks	Inspect / Repair	4-2, 4-3	○ **		
Fuel line	Inspect / Repair	4-3, 4-6		○	
Cooling system	Inspect / Clean	8-2	○		
Spark plug	Clean / Regap	3-2, 3-3		○	
	Inspect / Replace	3-3			○
Fuel strainer	Clean / Replace	4-2		○	
Leads and connections	Inspect / Repair	3-5		○	
Fuel tank	Clean inside.	4-3		○	
Muffler and exhaust port	Clean	8-3		○	
Starter system	Inspect / Repair	2-1 to 2-4		○	
Oil tank	Clean inside.			○	
Oil strainer	Clean / Replace	7-1		○	
Sprocket	Inspect / Replace	1-5, 5-1		○	
Guide bar	Inspect / Clean		○		
Chain brake	Inspect / Repair	6-1, 6-2	○		

Daily: Inspecting in every services.

IMPORTANT: Service intervals shown above are maximum. Actual use and your experience will determine the frequency of required maintenance.

* Retighten the following screws and bolts after first 1 week use, and every 3 months.

Starter assembly screws (4 pcs.)

Anti-vibration spring screws (6 pcs.)

Front handle screws (3 pcs.)

Muffler nuts (2 pcs.)

** Inspect after every refuel.

- Adhesive 4, 60
Air filter 17, 22 to 24, 27 to 30, 33, 54, 55, 71
Auto-oiler 6, 45, 48 to 50
Ball bearing 4, 6, 51, 58, 60
Bevel gear 65, 66
Brake band 42, 44
Brake connector 42, 44
Brake cover 42 to 44
Brake lever 4, 8, 42, 43, 55
Carburetor 2 to 4, 6, 22, 24, 27 to 31, 32 to 37, 54, 55, 71
Carburetor adjustment 29 to 31
Chain brake system 42
Chain oil discharge volume 3
Chain tensioner 65, 66
Choke rod 27, 33, 37
Cleaner case 22, 24, 27, 28, 33, 37, 54, 55
Clip 28, 46
Clutch assembly 6, 38 to 41, 55
Clutch drum 5, 38, 39, 41
Clutch hub 4, 38, 40
Clutch plate 6, 38 to 40
Clutch shoes 39, 40
Clutch spring 38, 40
Clutch system 38
Collar 19, 42, 65, 66
Compression gauge 6, 52
Compression pressure, cylinder 3, 7, 55
Connector 22, 23, 45, 54
Cooling air passage, engine 52
Crankcase 34, 54, 60
Crankcase pulse passage 34
Crankshaft 5 to 7, 12, 20, 21, 39 to 41, 51, 56 to 58
Cushions 64
Cylinder 2, 5 to 7, 15, 35, 51 to 53, 57, 60, 61
Cylinder compression 6, 52
Cylinder seal 54
Disassembly chart 70
Engine 2 to 4, 6, 7, 15, 29, 31, 36, 51, 52, 55, 61
Engine cover 42, 44, 45, 48, 50, 51, 61
Exhaust port, cylinder 29, 52 to 54, 71
Flywheel 4, 7, 13, 20, 21, 55
Fuel cap 22 to 24, 28
Fuel line 22, 24, 27 to 29, 33, 37, 71
Fuel return line 22, 27, 28, 33, 37, 71
Fuel strainer 22 to 24, 71
Fuel system 15, 22
Fuel tank 22 to 25, 28, 71
Fuel tank vent 22
Gasket, carburetor diaphragm 36
Grease 4, 41, 44, 64
Grommet, fuel tank 22, 24, 28
Grommet, oil tank 45, 47, 48
Ground lead 13, 17, 19
Guide bar 2 to 4, 65, 71
Guide bar mounting system 65
Guide bar stud 67
High tension lead 18, 19
H mixture needle 3, 29 to 31
Idle adjust screw 3, 29 to 31
Ignition coil 5, 13, 16, 18 to 20, 55
Ignition switch 4, 13, 15 to 17, 52
Ignition system 3, 6, 13, 15
Ignition timing 3, 6
Inlet needle valve 33, 35, 36
Intake bellows 34, 51, 54, 61
Intake insulator 4, 51, 55, 56, 61
Key, flywheel 20, 21, 55
L mixture needle 3, 29 to 31
Limiter cap 6, 29 to 31
Liquid gasket 4, 60
Maintenance guide 68
Metering diaphragm 34, 36
Metering lever 3, 6, 33 to 36
Metering lever height 3, 6, 33, 34
Minimum secondary voltage 3
Muffler 2, 4, 29, 52 to 55, 71
Needle bearing, clutch 4, 38, 39, 41
Needle bearing, piston pin 57
O-ring, fuel cap 22 to 24
O-ring, oil cap 45, 47
Oil cap 45, 47, 48
Oil line 45, 47, 48
Oil seal 6, 51, 54, 58, 60
Oil strainer 45, 48, 71
Oil tank vent 45 to 47
Piston 5, 6, 40, 51 to 53, 56, 57, 59, 60
Piston pin 5, 6, 51, 57, 59
Piston ring 5, 51, 52, 57, 59, 60
Pole shoe air gaps 3, 6, 19, 20
Pump diaphragm 33, 36
Purge bulb 22, 27, 28
Rear handle and control system 62
Rewind spring 7, 8, 10, 11
Rewind spring case 7, 8, 10
Rope reel 7 to 11
Saw chain 2, 3, 45
Saw chain lubrication system 45
Screen, carburetor inlet 36
Screen, spark arrestor 2, 53
Secondary coil resistance 3, 18
Service information 2
Service intervals 71
Service limits 5, 57
Spark plug 2 to 4, 12, 13, 15, 19, 20, 29, 34, 39, 52, 54, 71
Spark plug cap 13, 15, 18, 19, 39
Spark plug cap coil 13, 18, 19
Spark plug gap 3, 15
Spark tester 6, 15
Special repairing materials 4
Special tools 6
Specifications 2, 31
Spring, metering lever 33, 35
Spring pin 62, 63
Spring pin tool 62, 63
Sprocket guard 8, 39, 65
Starter grip 7, 9, 11, 15, 33, 34, 40
Starter pawl 4, 7, 12, 21
Starter rope 7 to 9, 11, 39
Starter system 7, 71
Switch lead 13, 16, 17, 19
Technical data 3, 52
Test pressure, carburetor 3
Throttle lockout 62, 63
Throttle rod 27, 33, 37
Throttle trigger 62, 63
Torque limits 4, 20
Torsion spring 12, 42, 62, 63
Troubleshooting guide 14, 68, 69
Welch plug 6, 36
Winter plug 32
Worm gear 38 to 41, 55

ECHO[®]

YAMABIKO