

ECHO®

shindaiwa®

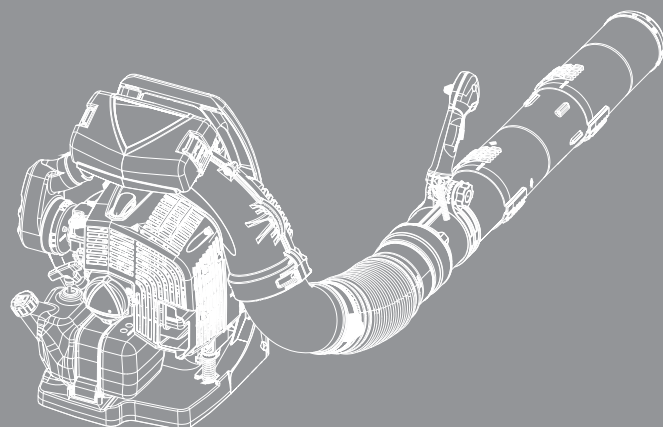

SERVICE MANUAL

ECHO: PB-8010
shindaiwa: EB810
(Serial number: 38000001 and after)

REVISED NOV. 2020
Ref. No. 403-21

INTRODUCTION

This service manual contains information for service and maintenance of **ECHO BACKPACK BLOWER** model **PB-8010** and **shindaiwa BACKPACK BLOWER** model **EB810**.

For systematic diagnosis, to avoid extra work, time loss and to meet Emission regulation, please refer to “Troubleshooting guide” that describes problems, testing, remedies and references. We recommend you make use of Operator’s Manual and Parts Catalogue together with this manual when servicing.

We are constantly working on technical improvement of our products. For this reason, technical data, equipment and design are subject to change without notice. All specifications, illustrations and directions in this manual are based on the latest product information available at the time of publication.

	Page	Page
1 SERVICE INFORMATION	2	
1-1 Specifications	2	
1-2 Technical data	3	
1-3 Torque limits	4	
1-4 Special repairing materials.....	4	
1-5 Service limits	5	
1-6 Special tools	6	
2 STARTER SYSTEM	7	
2-1 Disassembling starter assembly.....	8	
2-2 Replacing starter rope	9	
2-3 Installing rewind spring.....	10	
2-4 Assembling starter.....	12	
2-5 Replacing starter pawl.....	13	
3 IGNITION SYSTEM	14	
3-1 Troubleshooting guide.....	15	
3-2 Testing spark	16	
3-3 Inspecting spark plug	16	
3-4 Replacing spark plug cap and coil.....	17	
3-5 Inspecting ignition switch.....	17	
3-6 Replacing ignition switch	18	
3-7 Inspecting ignition coil resistance.....	21	
3-8 Replacing ignition coil.....	22	
3-9 Setting pole shoe air gaps.....	22	
3-10 Inspecting and replacing magneto rotor	23	
3-11 Inspecting and replacing woodruff key	23	
4 FUEL SYSTEM	24	
4-1 Inspecting air filter	25	
4-2 Inspecting fuel cap and fuel strainer.....	25	
4-3 Inspecting fuel tank and line.....	26	
4-4 Replacing fuel lines and grommet.....	27	
4-5 Inspecting tank vent	28	
4-6 Replacing carburetor.....	29	
4-7 Testing carburetor.....	30	
4-8 Inspecting crankcase pulse passage	31	
4-9 Inspecting metering lever height	31	
4-10 Inspecting inlet needle valve	32	
4-11 Inspecting diaphragm and others.....	33	
4-12 Inspecting main jet	33	
4-13 Adjusting carburetor	34	
4-13-1 General adjusting rules	34	
4-13-2 Initial setting Throttle adjust screw, L mixture needle and H mixture needle.....	34	
4-13-3 Adjusting carburetor	35	
4-14 Checking and adjusting throttle cable	35	
5 BACKPACK FRAME	36	
5-1 Removing backpack frame assembly.....	37	
5-2 Replacing backpack harness	38	
5-3 Replacing backpack harness	39	
6 BLOWER SYSTEM	40	
6-1 Separating fan case assembly	41	
6-2 Replacing elbow	42	
6-3 Disassembling and assembling fan.....	43	
6-4 Replacing fan case.....	43	
7 ENGINE	45	
7-1 Testing cylinder compression	46	
7-2 Cleaning cooling air passages	46	
7-3 Inspecting muffler and exhaust port	47	
7-4 Testing crankcase and cylinder sealings.....	48	
7-5 Replacing oil seal	49	
7-6 Inspecting cylinder.....	50	
7-7 Inspecting piston and piston ring.....	51	
7-8 Disassembling crankcase.....	51	
7-9 Replacing ball bearings	52	
7-10 Removing ball bearing in crankcase	52	
7-11 Assembling crankshaft and crankcase.....	53	
7-12 Installing piston.....	53	
7-13 Installing piston ring and cylinder	54	
7-14 Assembling engine assembly and other parts	55	
8 MAINTENANCE GUIDE	56	
8-1 Troubleshooting guide.....	56	
8-2 Disassembly chart.....	58	
8-3 Service intervals	59	

1 SERVICE INFORMATION

1-1 Specifications

Dimensions*	Length	mm (in)	362 (14.3)
	Width	mm (in)	526 (20.7)
	Height	mm (in)	544 (21.4)
Dry weight**		kg (lb)	11.2 (24.7)
Engine	Type	YAMABIKO, stratified scavenging, air-cooled, two-stroke, single cylinder	
	Rotation	Counterclockwise as viewed from the output end	
	Displacement	cm ³ (in ³)	79.9 (4.875)
	Bore	mm (in)	53.0 (2.087)
	Stroke	mm (in)	36.2 (1.425)
	Compression ratio	6.9	
Carburetor	Type	Diaphragm, horizontal-draft, with purge bulb	
	Model	Walbro WYAB-1	
	Venturi size	mm (in)	10.0 x 16.0 (0.39 x 0.63)
	Throttle bore	mm (in)	16.7 x 16.0 (0.66 x 0.63)
	Air valve venturi	mm (in)	15 (0.59)
Ignition	Type	CDI (Capacitor discharge ignition) system Digital magneto	
	Spark plug	NGK CMR7H	
Exhaust	Muffler type	Spark arrester muffler	
Starter	Type	Automatic rewind	
	Rope diameter x length	mm (in)	3.8 x 1100 (0.15 x 43.3)
Fuel* ¹	Type* ²	Mixed two-stroke fuel	
	Mixture ratio	50 : 1 (2%)	
	Gasoline	Minimum 89 octane	
	Two-stroke air cooled engine oil	ISO-L-EGD (ISO/CD13738), JASO FC/FD	
	Tank capacity	Full tank capacity: 2.56 (86.6) Usable capacity: 2.48 (83.9) L (U.S.fl.oz.)	
Throttle	Type	Throttle control and Throttle setting device	
Blower	Fan type	Centrifugal, single stage	
	Max. air volume (with pipes)	m ³ /min (cfm)	30.3 (1071)
	Max. air velocity (with pipes)	m/s (mph)	94.5 (211)
	Discharge ID* ³	mm (in)	90.0 (3.5)

*Without blower pipes **With blower pipes

*¹ Refer to Operator's manual

*² Premixed alkylate fuel for 2-stroke can be used.

*³ Inner diameter

1-2 Technical data

Engine			
Compression pressure	MPa (kgf/cm ²) (psi)		1.03 (10.5) (150)
Ignition system			
Spark plug gap	mm(in)		0.6 - 0.7 (0.024 - 0.028)
Spark test	Tester gap w/ spark plug	mm(in)	4.0 (0.16)
	Tester gap w/o spark plug	mm(in)	6.0 (0.24)
Secondary coil resistance	Ω		785 - 1185
Pole shoe air gaps	mm(in)		0.3 - 0.4 (0.012 - 0.016)
Ignition timing	at 3,000 r/min	°BTDC	27
	at 7,500 r/min	°BTDC	30
Carburetor			
Test Pressure, minimum	MPa (kgf/cm ²) (psi)		0.05 (0.5) (7.0)
Metering lever height	mm(in)		1.50 (0.06) lower than diaphragm seat
Limiting plug / cap			-
Tool to adjust mixture needles			Short type D-shaped tool(S) P/N 91159S
Carburetor adjustment			
1) Initial setting			
H mixture needle	turn out		2 1/2
L mixture needle	turn out		2
Throttle adjust screw	turn out* ¹		9 1/4
Engine warm-up	Idle - WOT : Total	sec.	30 - 180 : 210
2) Find idle maximum speed			Adjust L mixture needle to maximum idle speed
3) Set idle maximum speed w/ TAS		r/min	2900
4) Set idle speed by turning L mixture needle CCW		r/min	2500
5) Find WOT maximum speed			First, warm-up 180 sec. with WOT engine speed 7650 r/min over and adjust H mixture needle to maximum WOT speed.
6) WOT setting		r/min	Turn H mixture needle CCW to decrease WOT speed by : 60 - 80
7) Verify final engine speed with standard equipment		r/min	Idle: 2300 - 2700 WOT: 7500 <

BTDC: Before top dead center **WOT:** Wide open throttle **CCW:** Counterclockwise **TAS:** Throttle adjust screw

*¹ Turn TAS clockwise until its head touches boss. Then turn TAS counterclockwise.

1-3 Torque limits

Descriptions		Size	kgf•cm	N•m	in•lbf	
Starter system	Starter case**	M5*	45 - 65	4.5 - 6.5	40 - 55	
Ignition system	Magneto rotor (Flywheel)	M10	300 - 400	30 - 40	260 - 348	
	Ignition coil	M4*	30 - 45	3 - 4.5	25 - 40	
	Spark plug	M10	100 - 150	10 - 15	87 - 130	
Fuel system	Carburetor	M5	40 - 60	4 - 6	32 - 50	
	Intake insulator	M5*	60 - 80	6 - 8	50 - 70	
Engine	Crankcase	M5	60 - 90	6 - 9	50 - 80	
	Cylinder	M5*	70 - 90	7 - 9	60 - 80	
	Engine mount		M6*	140 - 180	14 - 18	120 - 157
		with lead	M6*	130 - 180	13 - 18	110 - 157
	Engine cover	Fan case side	M5 [†]	20 - 40	2 - 4	17 - 32
		Crankcase side**	M5*	45 - 65	4.5 - 6.5	40 - 55
	Muffler	M6	100 - 140	10 - 14	87 - 120	
Others	Fancase	M5 [†]	25 - 45	2.5 - 4.5	22 - 40	
	Blower fan	M10	300 - 340	30 - 34	260 - 280	
	Fuel tank	M5*	20 - 40	2 - 4	17 - 32	
	Cleaner case	M5 [†]	25 - 40	2.5 - 4	22 - 32	
	Cylinder cover	M4	15 - 45	1.5 - 4.5	13 - 40	
	Back pack frame	Fan case side	M5 [†]	25 - 45	2.5 - 4.5	22 - 40
		Bottom side	M5 [†]	35 - 60	3.5 - 6	30 - 50
Regular bolt, nut and screw		M3	6 - 10	0.6 - 1	5 - 9	
		M4	15 - 25	1.5 - 2.5	13 - 22	
		M5	25 - 45	2.5 - 4.5	22 - 40	
		M6	45 - 75	4.5 - 7.5	40 - 65	
		M8	110 - 150	11 - 15	95 - 130	

* Precoat bolt: If the coat is peeled off, replace new one or apply thread locking sealant as shown below.

[†] Tapping screw

** Bolts on PB-8010 were changed. Refer to Technical Information Y2020-695 for details.

1-4 Special repairing materials

Material	Location	Remarks
Grease	Oil seal inner lips	EPNOC AP2 (Lithium based grease) P/N X695-000060
	Rewind spring	
	Starter center post	
	Main pipe O-ring	
Thread locking sealant	Ignition coil (re-use*)	ThreeBond #1344J or equivalent
	Engine mount (re-use*)	
	Cylinder (re-use*)	Loctite #272 or equivalent
	Intake insulator (re-use*)	ThreeBond #1324N or equivalent
	Fuel tank (re-use*)	
	Starter case (re-use*)	
	Crankcase side engine cover (re-use*)	

*If old thread locking sealant is left in threads, correct torque may not be secured. In case old thread locking sealant is left, remove it.

1-5 Service limits

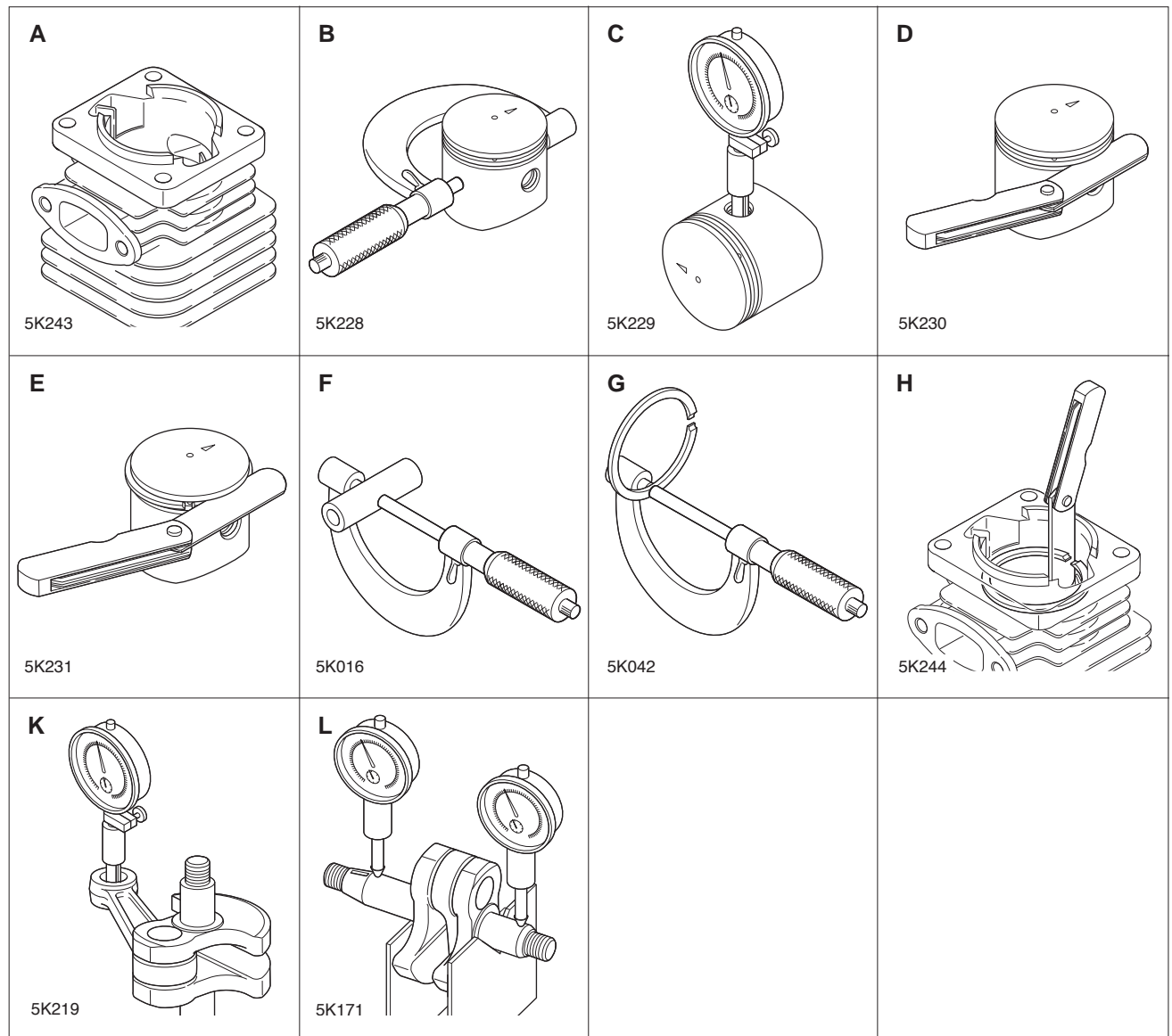

Description		mm (in)	
A	Cylinder bore	When plating is worn and aluminum can be seen	
B	Piston outer diameter	Min.	52.88 (2.082)
C	Piston pin bore	Max.	13.030 (0.5130)
D	Piston ring groove	Max.	1.3 (0.051)
E	Piston ring side clearance	Max.	0.15 (0.006)
F	Piston pin outer diameter	Min.	12.98 (0.5110)
G	Piston ring width	Min.	1.15 (0.045)
H	Piston ring end gap	Max.	0.5 (0.02)
K	Con-rod small end bore	Max.	16.025 (0.6309)
L	Crankshaft runout	Max.	0.02 (0.000 8)

1-6 Special tools

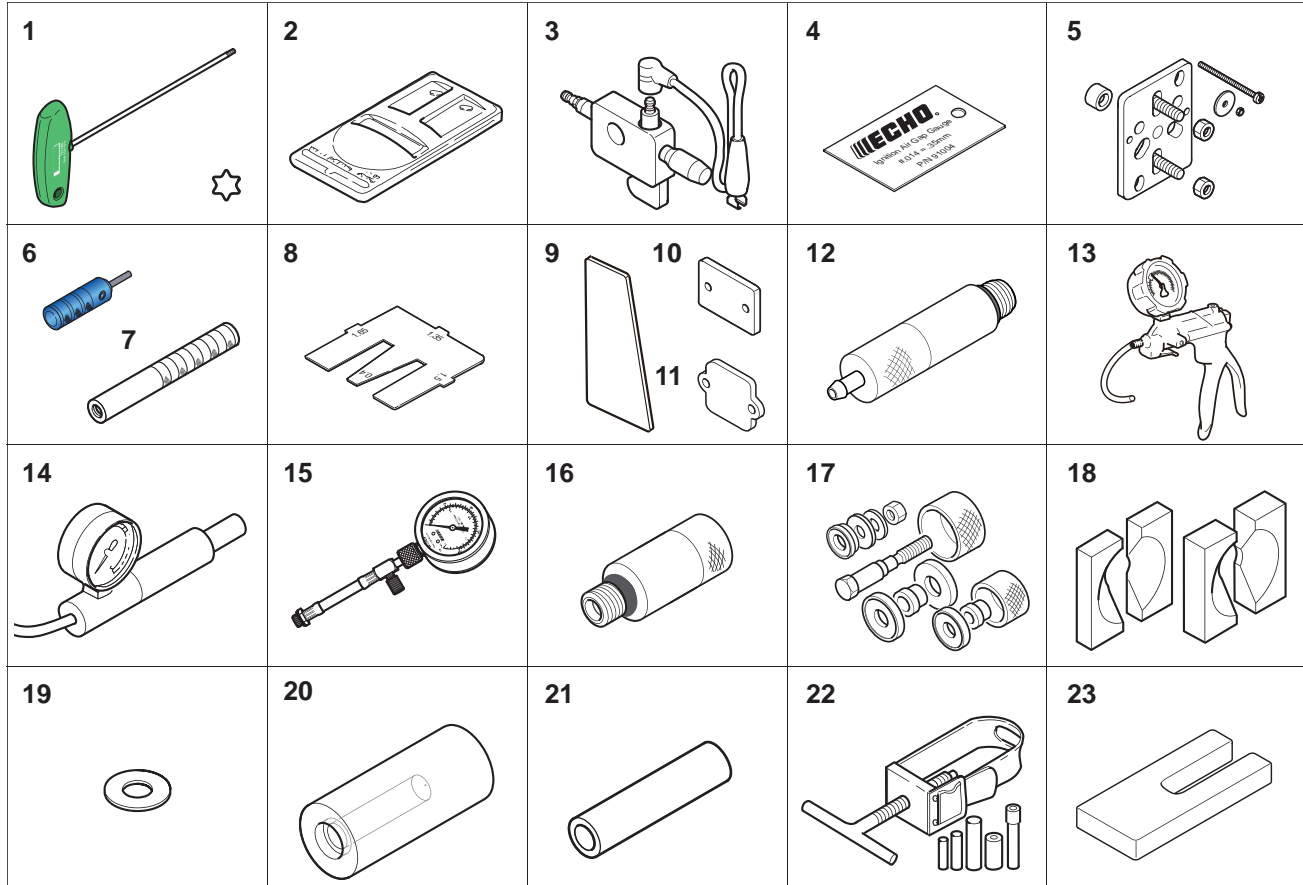

Key	Part Number	Description	Reference
1	X602-000340	Torx wrench (T27)	Removing and installing torx bolt
2	897802-33330	Tachometer PET-1000R	Measuring engine speed to adjust carburetor
3	897800-79931	Spark tester	Checking ignition system
4	91004	Module air gap gauge	Adjusting pole shoe air gaps
5	Y089-000111	Puller	Removing magneto rotor (flywheel) and crankcase
6	91159S	Short type D-shaped tool(S)	Adjusting carburetor
7	91087	Fan remover	Removing blower fan
8	897563-19830	Metering lever gauge	Measuring metering lever height on carburetor
9	91041	Pressure rubber plug	Plugging exhaust port to test crankcase / cylinder leakages
10	897826-16131	Pressure rubber plug	Plugging intake port to test crankcase / cylinder leakages
11	897827-16131	Pressure plate	Plugging intake port to test crankcase / cylinder leakages
12	A131-000160	Pressure connector	Testing crankcase and cylinder leakage
13	91149	Pressure / vacuum tester	Testing crankcase / cylinder leakages
14	897803-30133	Pressure tester	Testing carburetor and crankcase leakage
15	91037	Compression gauge	Measuring cylinder compression
16	P021-051690	Adapter	Measuring cylinder compression (with P/N: 91147)
17	897701-14732	Bearing tool	Removing and installing ball bearings on crankcase
18	897701-02830	Bearing wedge	Removing ball bearings on crankshaft
19	100014-18430	Washer	Installing crankcase oil seal (t: 0.5 mm)
20	897714-24330	Oil seal tool	Installing crankcase oil seal (starter side)
21	897726-21430	Oil seal tool	Installing crankcase oil seal (fan case side)
22	897702-30131	Piston pin tool	Removing and installing piston pin
23	897719-02830	Piston holder	Making piston steady to remove and install piston/ring

2 STARTER SYSTEM

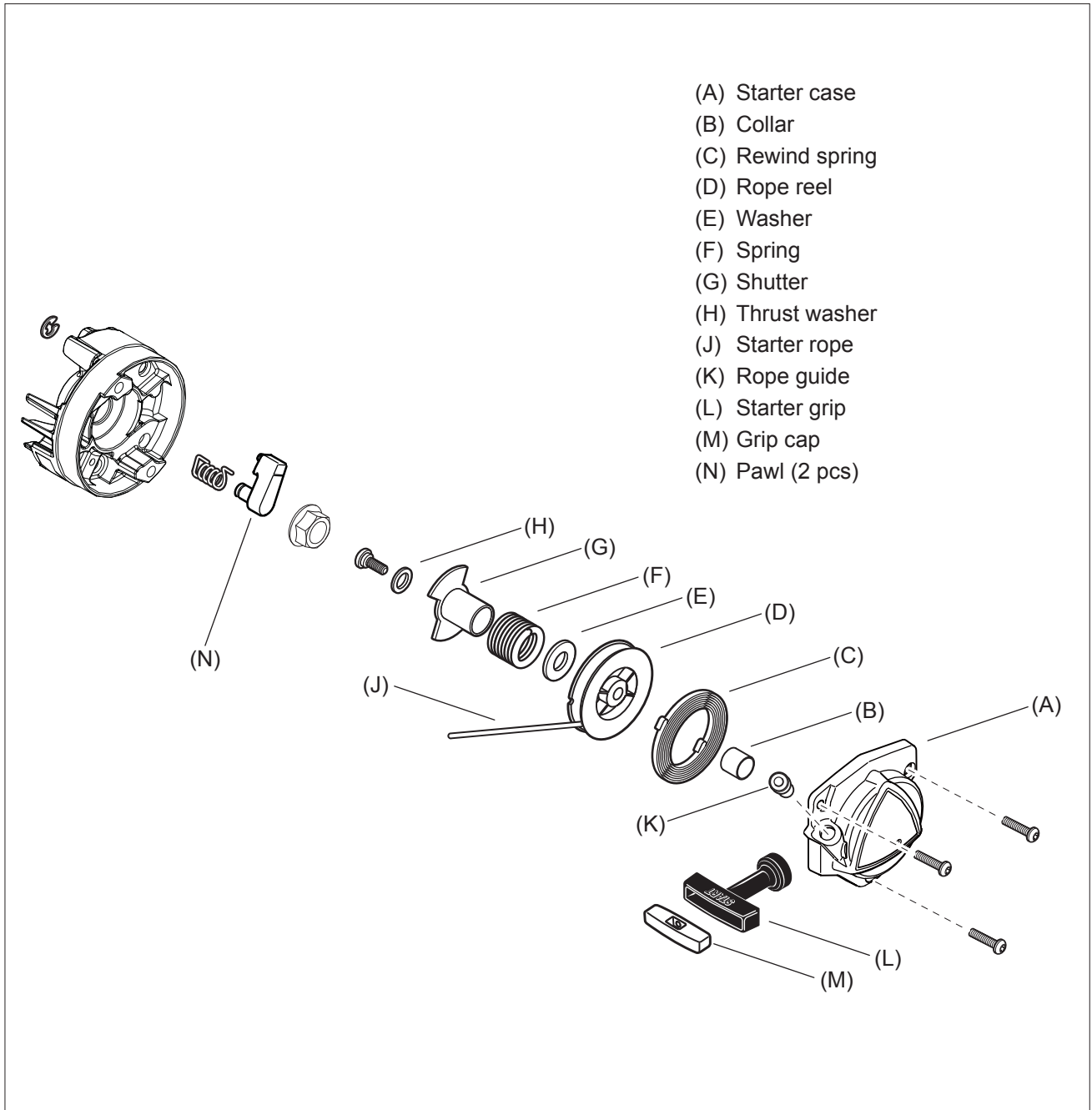

2-1 Disassembling starter assembly

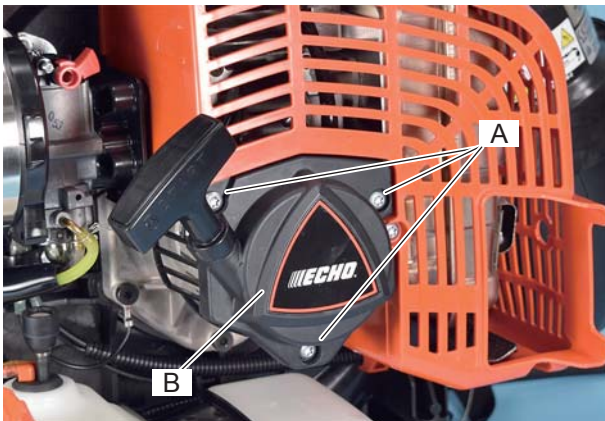

1. Remove 3 bolts (A) and remove starter assembly (B) from unit.

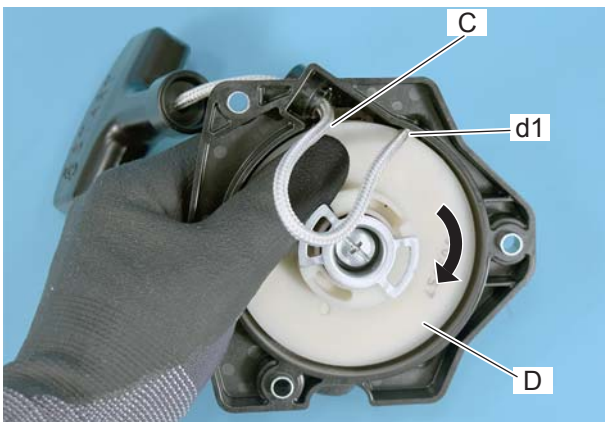

2. Pull out starter rope (C) about 30 cm (12 in) and hold rope reel (D) by hand. Hook excess rope on rope reel notch (d1) as shown.

3. Rotate rope reel (D) clockwise to release tension of rewind spring.

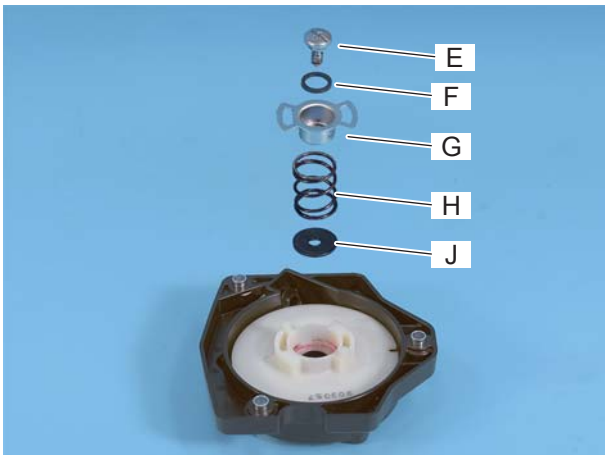

4. Remove screw (E), thrust washer (F), shutter (G), spring (H) and washer (J) from starter assembly.

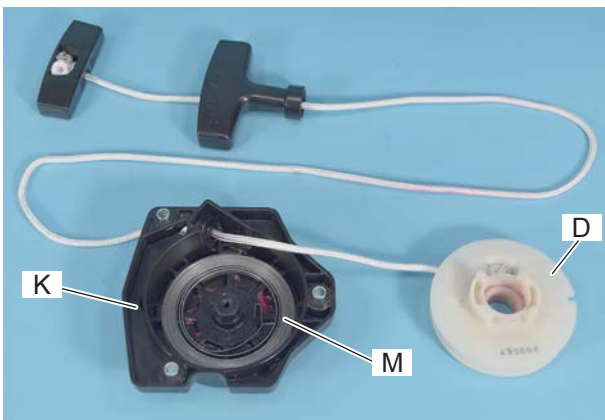

5. Remove rope reel (D) from starter case (K) slowly to prevent rewind spring (M) from unwinding.

WARNING  **DANGER**

Wear eye protection and take care when removing rope reel. Rewind spring may unwind suddenly and cause personal injury.

2-2 Replacing starter rope

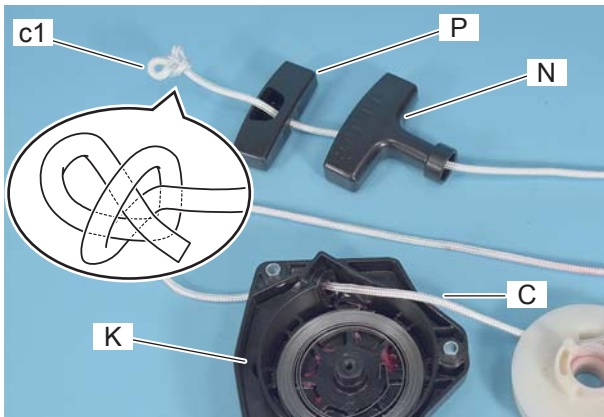
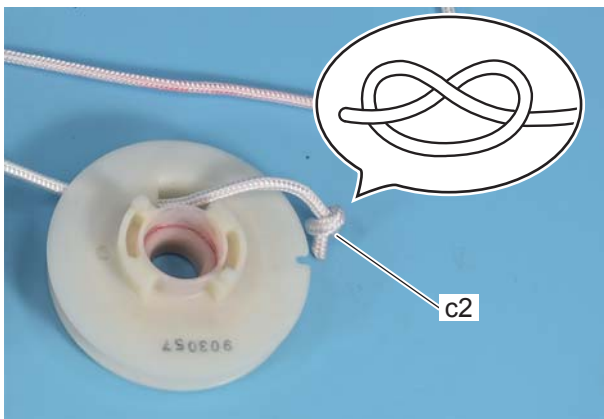
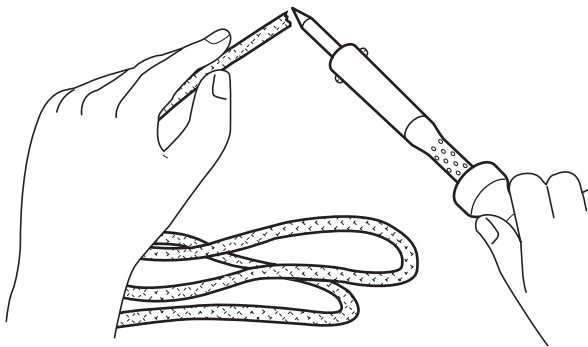

1. Pull out knot (c1) from starter grip and untie knot (c1).

2. Pull knot (c2) to remove rope from rope reel.

3. When installing a new starter rope, singe both ends of the rope to prevent fraying.

4. Make a knot (c2) at end of starter rope and pass the rope through hole of rope reel, then push the knot (c2) into recess as shown.

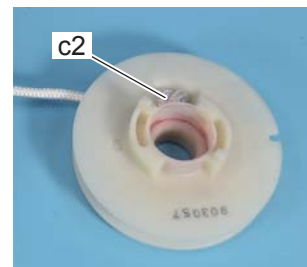

5. Pass the other end of starter rope (C) through starter case (K) from inside to outside.

6. Pass starter rope (C) through starter grip (N) and grip cap (P). Make a knot (c1) as shown.

7. Push the knot (c1) into recess of grip cap (P).

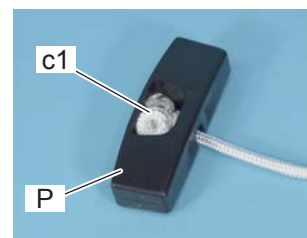

2-3 Installing rewind spring

WARNING DANGER

Wear eye protection and take care when removing rope reel. Rewind spring may unwind suddenly and cause personal injury.

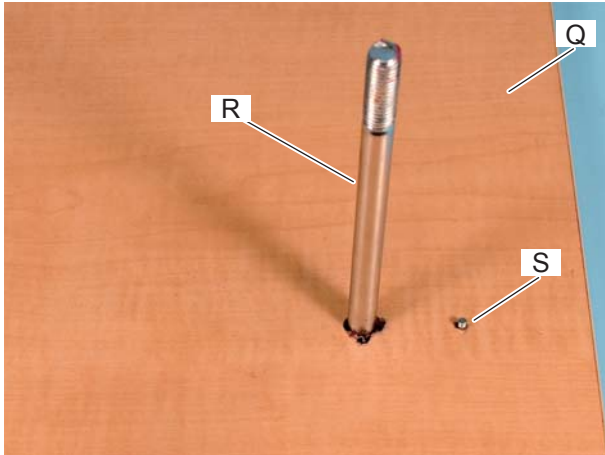

If rewind spring is popped out unexpectedly, follow steps 1) to 13) to install it into original position.

1) Due to large spring load, it is recommended to use the following tool.

2) This tool can be made by assembling suitable board (Q), bolt or bar (R; < 13 mm dia.) and bolt or bar (S; < 3 mm dia.) as follows.

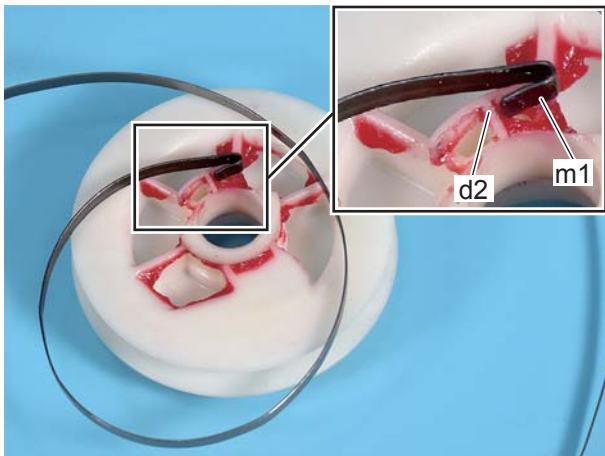
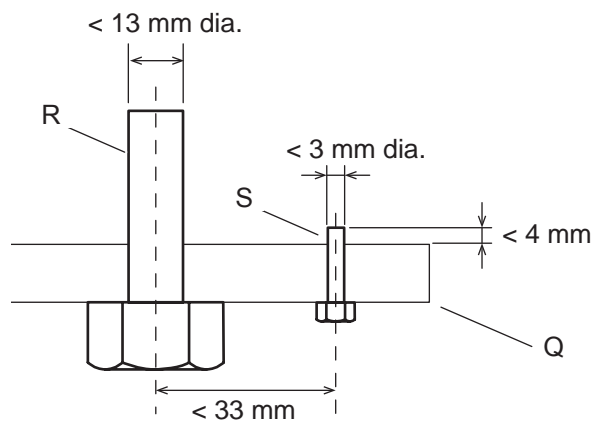

3) Set inner hook (m1) of rewind spring on rib (d2) of rope reel as shown.

4) Turn over rope reel (D) with rewind spring (M) and install the tool for winding spring as shown.

NOTE: Set rewind spring (M) inside the small bolt or bar (S) as shown.

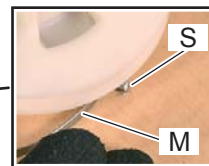
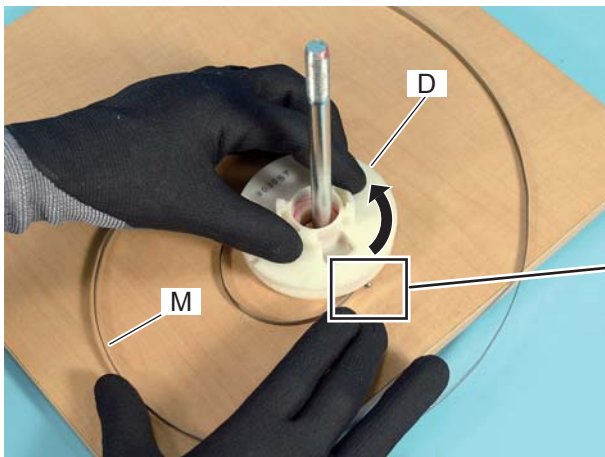

5) Turn rope reel (D) with rewind spring (M) counterclockwise to wind the spring.

2-3 Installing rewind spring (Continued)

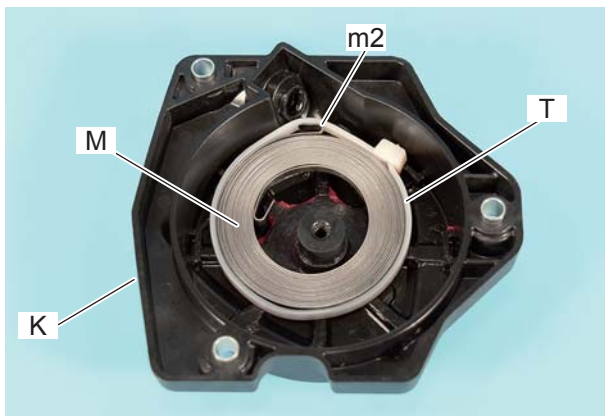
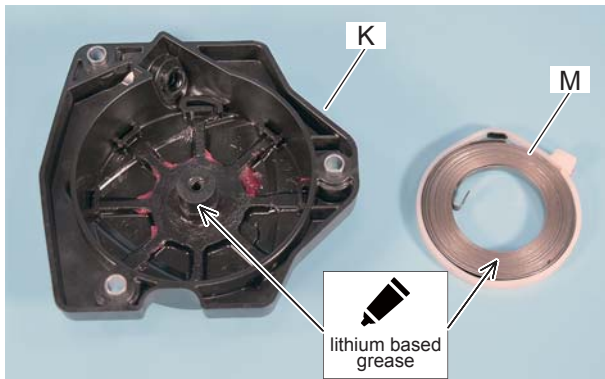

6) Continue to turn rope reel (D) counterclockwise until the outer hook (m2) of rewind spring is caught on the small bolt or bar (S) as shown.

7) While holding rope reel firmly to keep rewind spring wound, bind outside of wound rewind spring with strong string, such as cable tie (T) firmly not to unwind the spring.

8) Remove rope reel and rewind spring (M) gently.

9) Cut off the rest (t1) of cable tie.

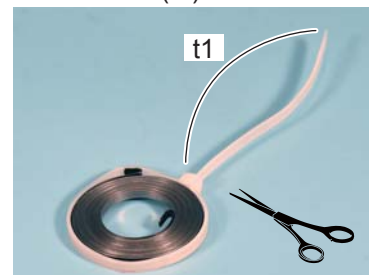

10) Apply small amount of lithium based grease to outside of rewind spring (M) and shaft of starter case (K).

11) Align outer hook (m2) of spring with holder (k1) of starter case.



12) Push rewind spring (M) down into the bottom of case, keeping the spring strongly pressed against case.

13) Spring (M) should fall into starter case and cable tie (T) can be removed.

NOTE: Rewind spring supplied as spare part is shipped in temporary retainer. Install the spring and remove the retainer as above step 11) to 13).

2-4 Assembling starter

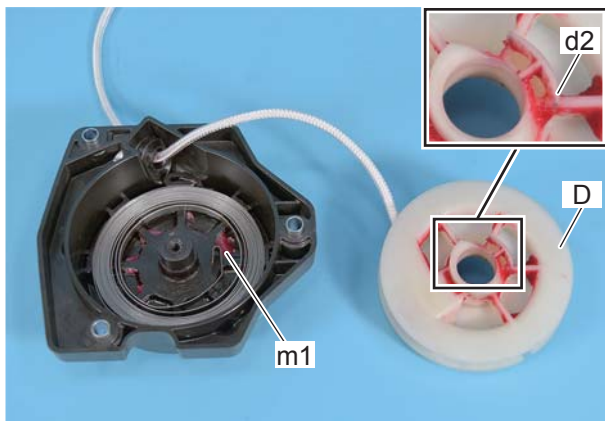

1. Install rope reel (D) engaging rib (d2) with inner hook (m1) of rewind spring.

NOTE: Check for proper engagement of rewind spring and rope reel (D) by turning rope reel (D) clockwise and counterclockwise.

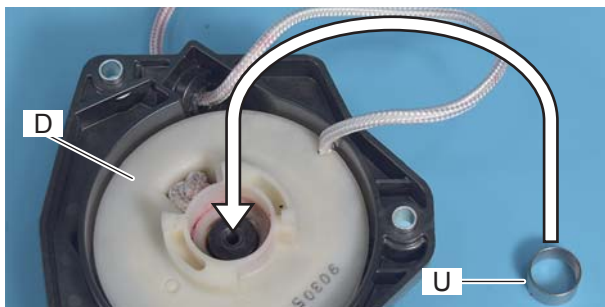
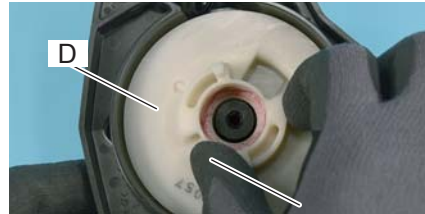

2. Insert collar (U) between shaft of starter case and rope reel (D).

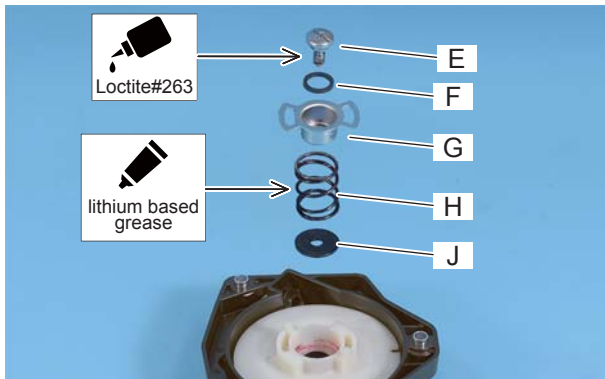

3. Apply small amount of lithium based grease to spring (H).

4. Install washer (J), spring (H), shutter (G) and thrust washer (F) to starter.

5. Apply thread locking sealant (Loctite #263 or equivalent) to bolt (E) and tighten the bolt (E).

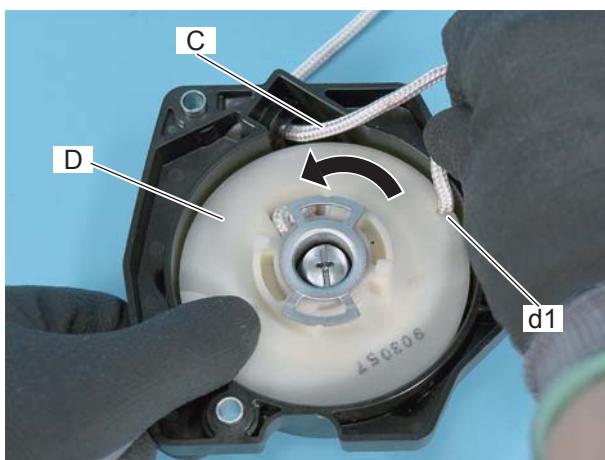

6. Pull out starter rope (C) inside of starter case. Rotate rope reel (D) counterclockwise several turns with starter rope hooked at notch (d1) as shown. Hold rope reel (D) to prevent it from unwinding and pull out starter grip to take the rope slack.

7. Pull starter several times to check rewind spring tension. If starter is not rewinding fully, increase spring tension by rotating rope reel (D) one more turn counterclockwise following above step 6.

8. Pull out starter rope all the way, and check that rope reel (D) can be rotated an additional half or more turn counterclockwise as shown, to prevent rewind spring from breaking.

9. If rope reel (D) can not be turned counterclockwise, reduce tension by rotating rope reel (D) clockwise one turn with starter rope hooked at notch (d1).

2-5 Replacing starter pawl

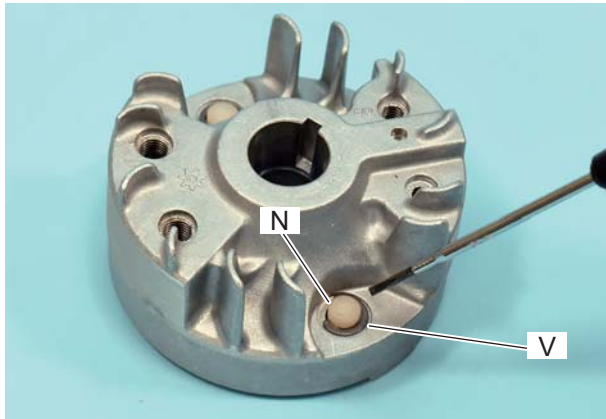

1. Remove magneto roter (Refer to "3-10 Inspecting and replacing magneto rotor").

2. Remove E-ring (V) from pawl (N).

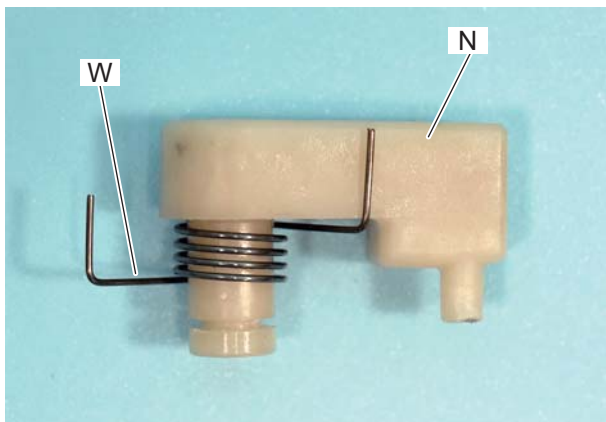

3. Inspect spring (W) and pawl (N) for damage. Replace the part(s) as required.

4. Install spring (W) to pawl (N) as shown.

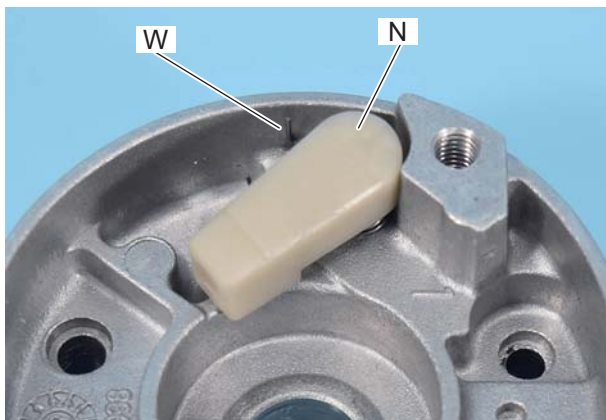

5. Install spring (W) and pawl (N) to magneto roter as shown.

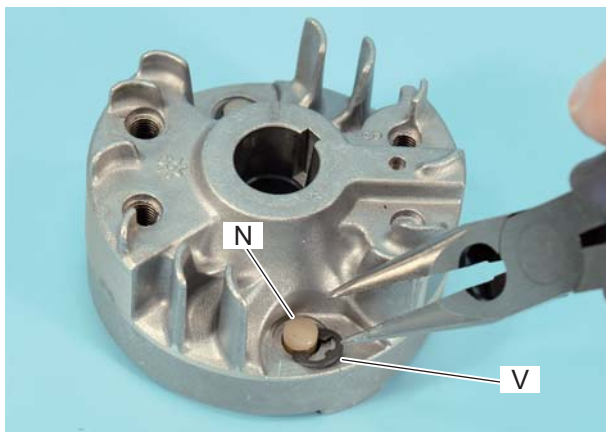

6. Install new E-ring (V) to pawl (N).

3 IGNITION SYSTEM

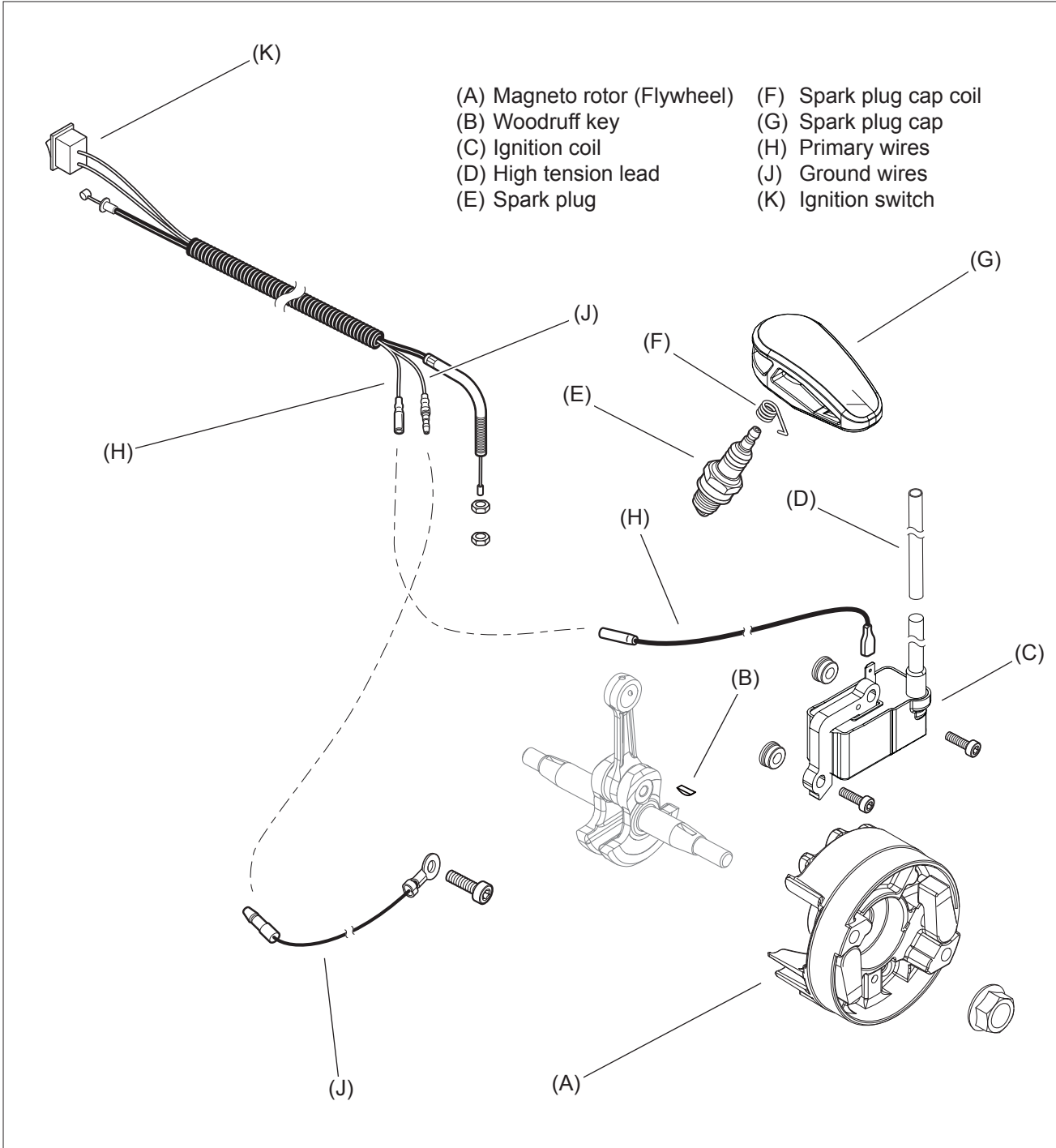

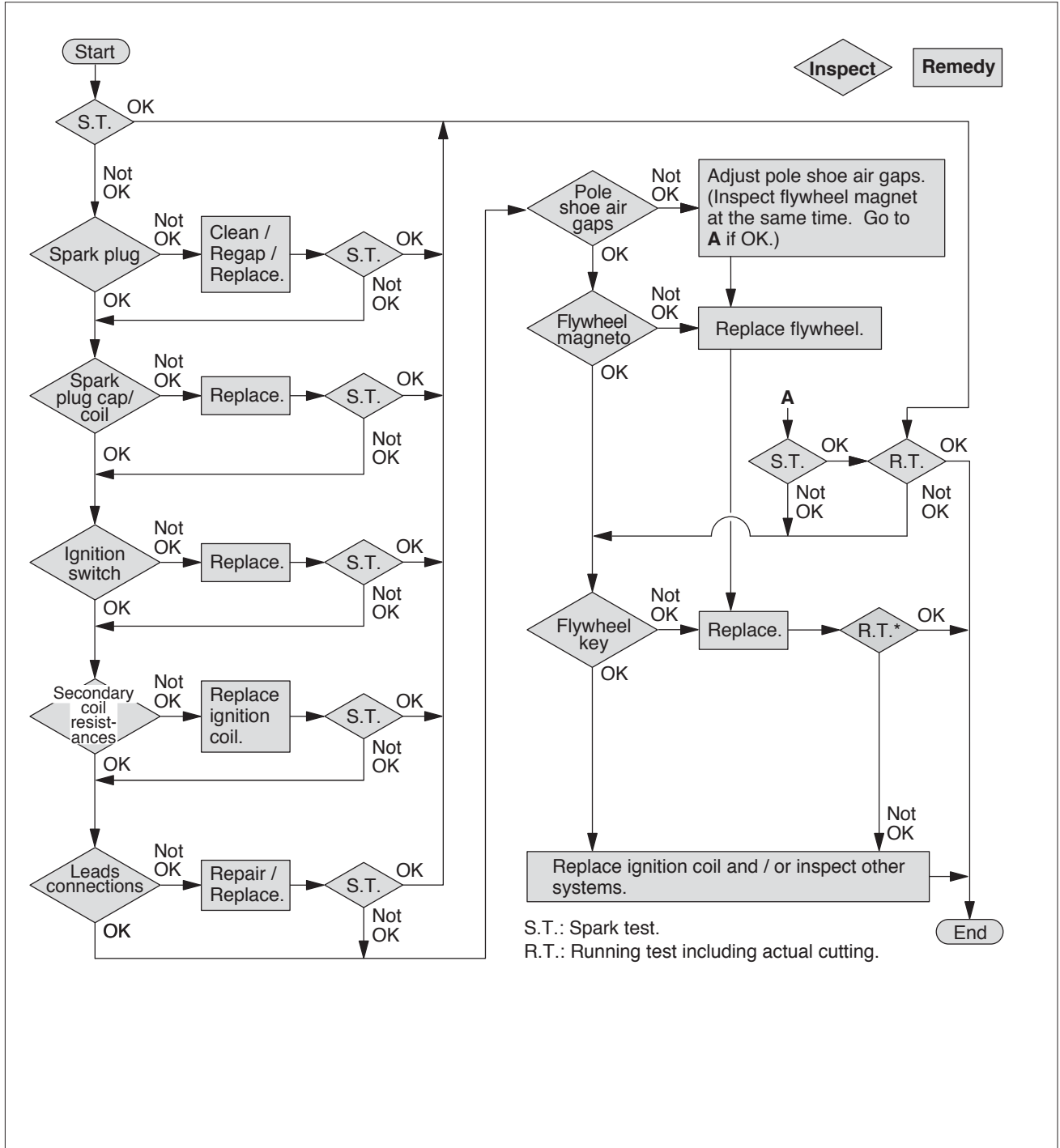

3-1 Troubleshooting guide

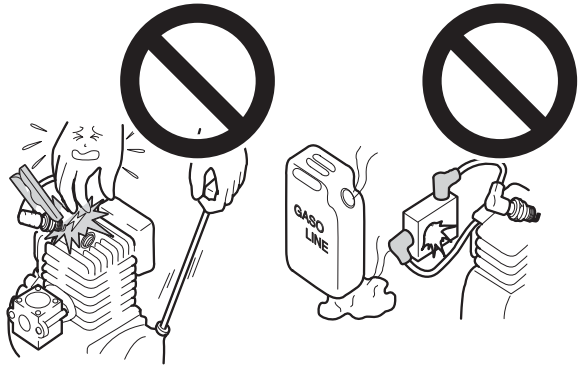
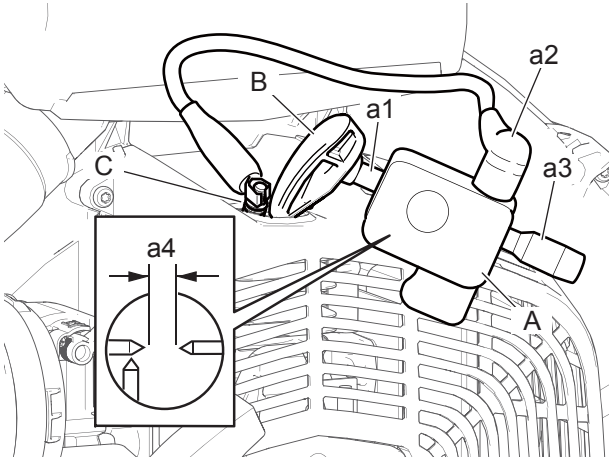

S.T.: Spark test.
R.T.: Running test including actual cutting.

3-2 Testing spark

WARNING  **DANGER**

*Do not test near spark plug hole without spark plug installed, otherwise there is a chance to ignite fuel mixture inside cylinder.

*Do not touch metal parts of spark tester while performing the test to avoid receiving electrical shock.

*Do not check spark in area where gasoline is spilled or flammable gases may exist.

Using Spark tester 897800-79931 (A)

1. Pull off spark plug cap (B).
2. Push high tension terminal (a1) onto spark plug cap (B). Connect ground terminal (a2) to spark plug (C).
3. Screw in adjuster (a3) until the needle tips contact. Turn out the adjuster 4 turns to set spark tester gap (a4) to 4 mm (0.16 in).
4. Pull the starter grip several times.
5. If spark is steady blue or white at the tester gap, ignition system is considered good. Go to inspecting spark plug.
6. If no spark exists or spark is intermittent in yellow, orange, or red, continue with further inspection.

3-3 Inspecting spark plug

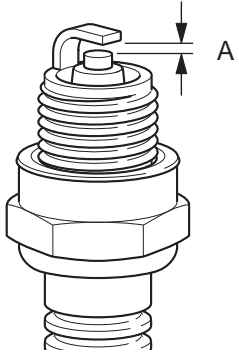

1. Remove spark plug to inspect for spark plug gap fouling, cracked or broken insulator, cracked outer electrode, or rounded center electrode. Replace spark plug as required.

Spark plug gap (A) standard:
0.6 to 0.7 mm (0.024 to 0.028 in)

2. If engine does not start with correct spark plug, inspect if spark plug is wet or dry. If it is excessively wet or dry, inspect fuel system.

3-4 Inspecting and Replacing spark plug cap and coil

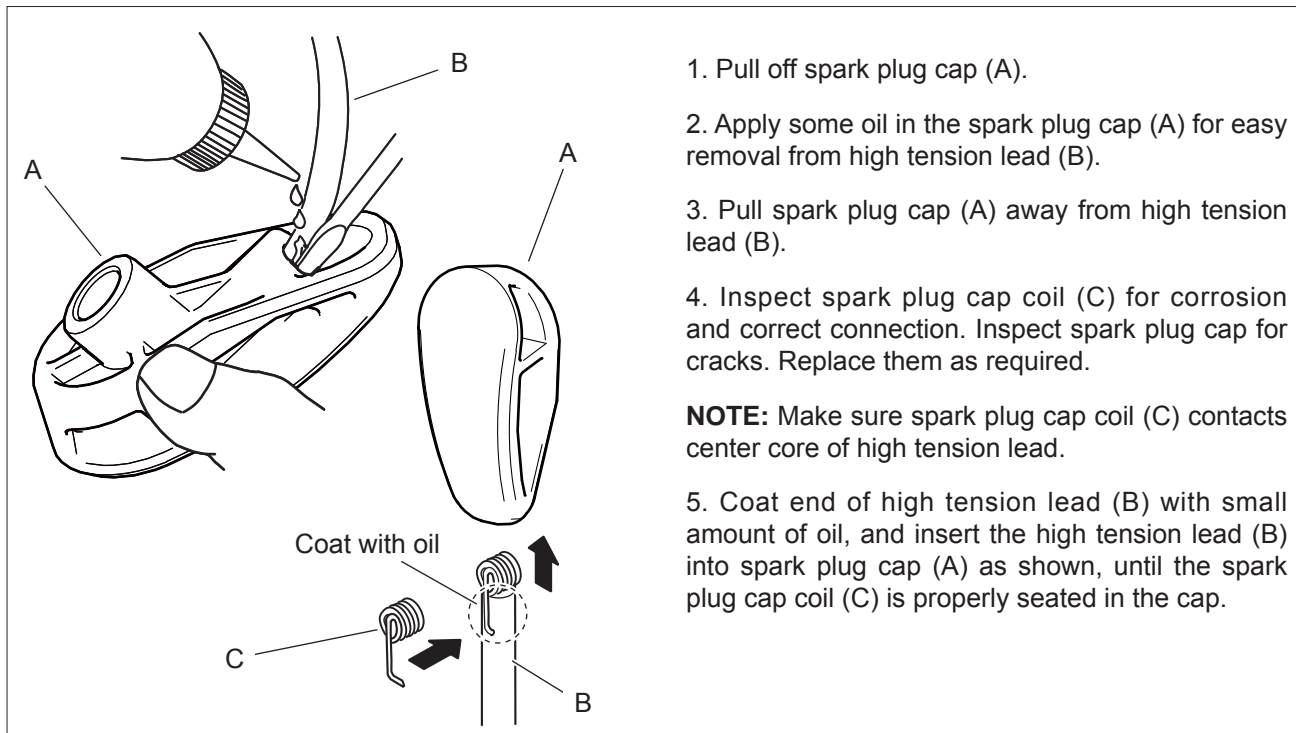

1. Pull off spark plug cap (A).
 2. Apply some oil in the spark plug cap (A) for easy removal from high tension lead (B).
 3. Pull spark plug cap (A) away from high tension lead (B).
 4. Inspect spark plug cap coil (C) for corrosion and correct connection. Inspect spark plug cap for cracks. Replace them as required.
- NOTE:** Make sure spark plug cap coil (C) contacts center core of high tension lead.
5. Coat end of high tension lead (B) with small amount of oil, and insert the high tension lead (B) into spark plug cap (A) as shown, until the spark plug cap coil (C) is properly seated in the cap.

3-5 Inspecting ignition switch



1. Loosen bolt (A).
2. Disconnect primary wire (B) and ground wire (C).

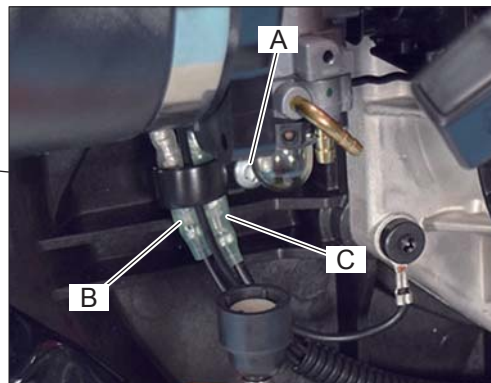

3. Connect Ohm-meter or Multi-meter to primary wire (B) and ground wire (C) as shown.
4. When ignition switch is in "RUN" position, the tester should indicate infinite resistance.
5. When ignition switch is in "STOP" position, the tester should show that circuit is in conducting state (closed circuit).
6. If not, replace the ignition switch with new one (Go to "3-6 Replacing ignition switch").



3-6 Replacing ignition switch

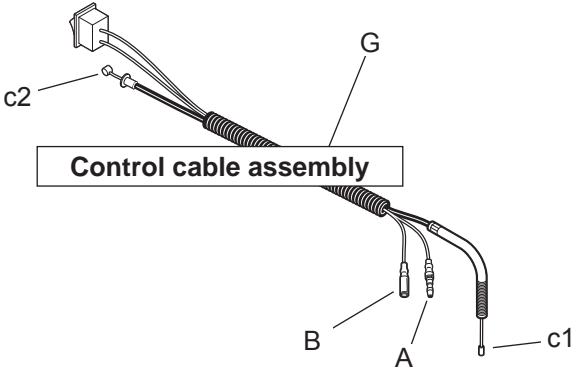

Control cable assembly

The diagram shows a control cable assembly with a connector at the top left labeled 'c2'. The main cable is labeled 'G'. At the bottom right, there are two wires labeled 'B' and 'A', and a throttle cable end labeled 'c1'.

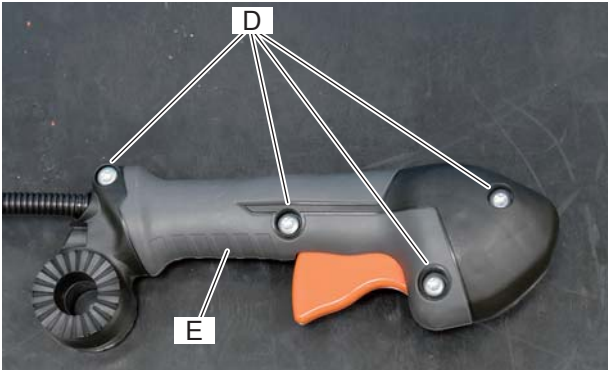

The photograph shows the handle grip with four screws labeled 'D' and the handle grip half labeled 'E'.

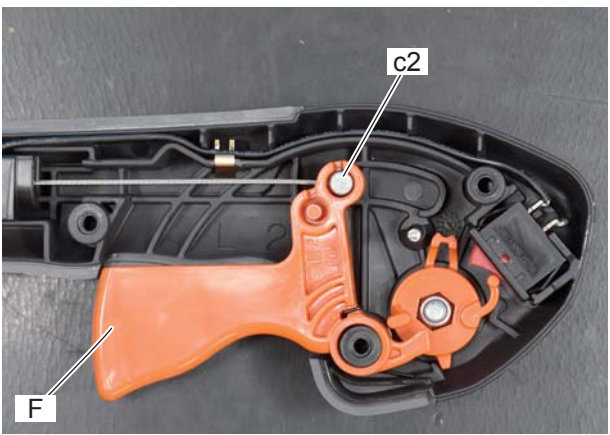

The photograph shows the handle grip assembly with the throttle cable end labeled 'c2' and the throttle trigger labeled 'F'.

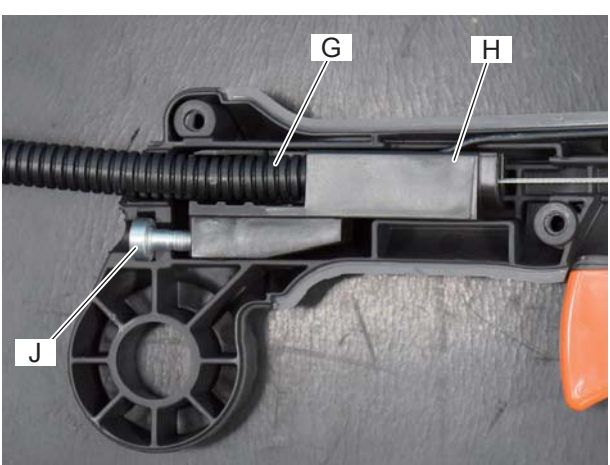

The photograph shows the handle grip assembly with the control cable assembly labeled 'G', the cable connector labeled 'H', and the bolt labeled 'J'.

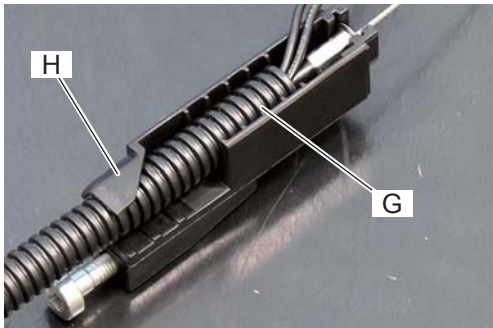

The close-up photograph shows the cable connector labeled 'H' and the control cable assembly labeled 'G'.

If ignition switch is damaged, the entire control cable assembly (G) must be replaced.

Removing

1. Disconnect primary wire (A) and ground wire (B) (Refer to 3-5 Inspecting ignition switch).
2. Disconnect throttle cable end (c1) from carburetor.
3. Remove four screws (D).
4. Remove handle grip half (E).
5. Disconnect throttle cable end (c2) from throttle trigger (F).
6. Pull control cable assembly (G) with cable connector (H) and bolt (J) out from the handle grip.
7. Pull control cable assembly (G) out from the cable connector (H).

3-6 Replacing ignition switch (continued)

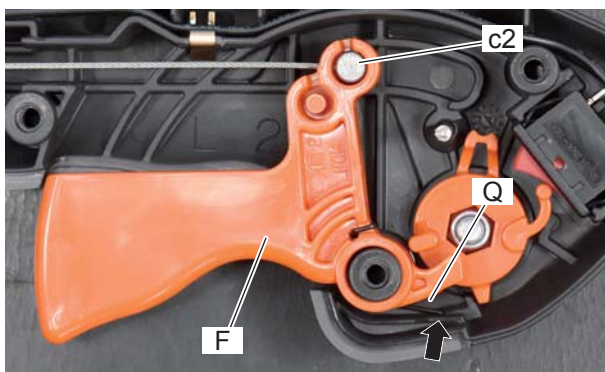
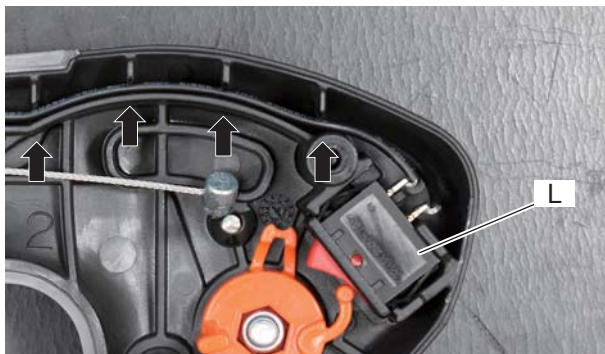
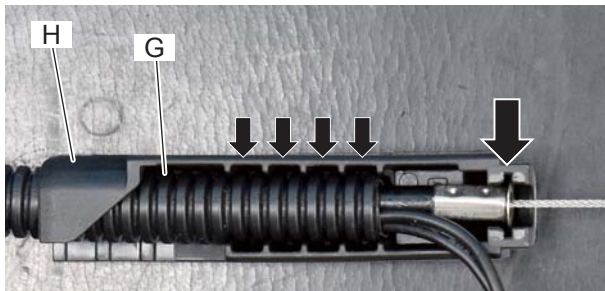
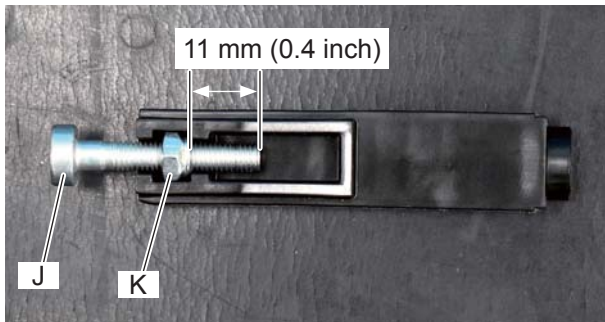
**Installing**

1. If replacing bolt (J) and nut (K) stored in the cable connector, insert them into the groove until the nut is fully seated.

2. Install control cable assembly (G) into the groove of the cable connector (H) as shown.

3. Install ignition switch (L) into the groove.

4. Fit the primary wire and ground wire in the groove.

5. Pinch clip (M) on the rubber part (N).

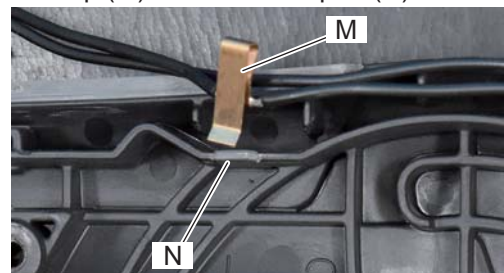

6. Install cable connector (H) and bolt (J) with control cable assembly (G) into the groove.

7. Install throttle trigger (F) with torsion spring (Q). Make sure the end of the torsion spring (Q) is fully seated in the handle grip.

8. Connect throttle cable (c2) to the trigger (F).

9. Put together both grip halves and tighten them with four screws.

3-6 Replacing ignition switch (continued)

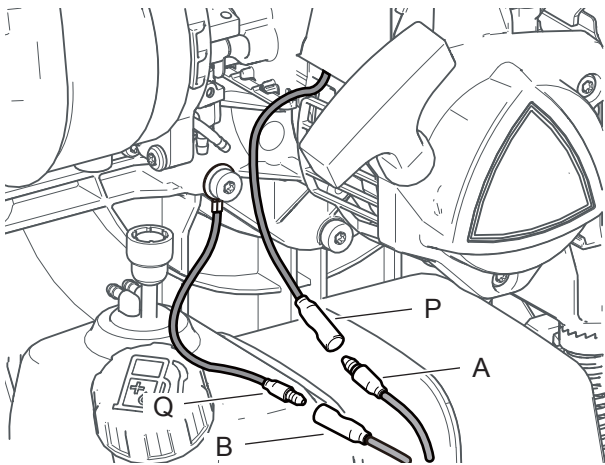

10. Connect throttle cable to carburetor (Refer to “4-14 Checking and adjusting throttle cable”).

11. Connect primary wire (A) and (P)

12. Connect ground wire (B) and (Q).

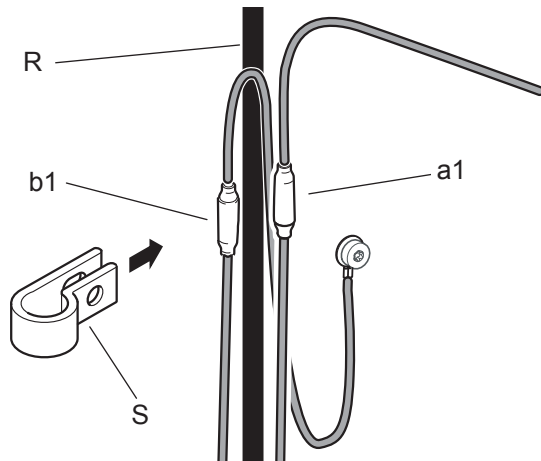

13. Bind primary wire terminal (a1), ground wire terminal (b1) and control cable (R) with clip (S).

14. Secure the clip (S) to fan case with bolt.

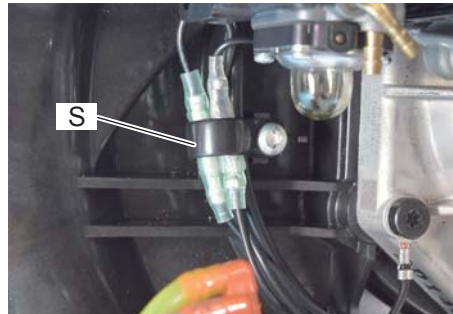

15. Put primary wire (A) into ribs of intake insulator as shown.

NOTE: Make sure not to contact primary wire (A) and debris guard (T).

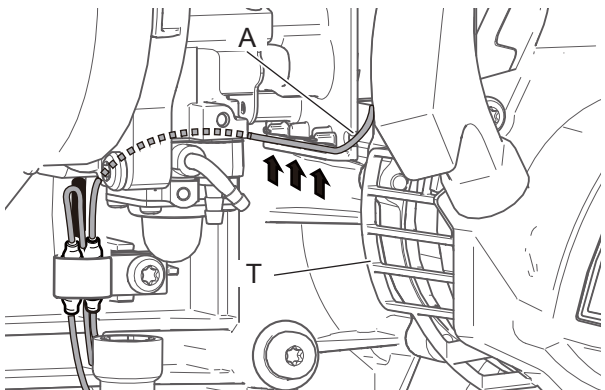

16. Route control cable assembly (G) as shown.

17. Put control cable assembly (G) into groove on engine cover as shown.

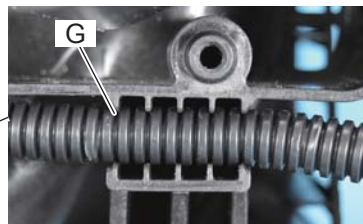

18. Reassemble all removed parts.

3-7 Inspecting ignition coil resistance

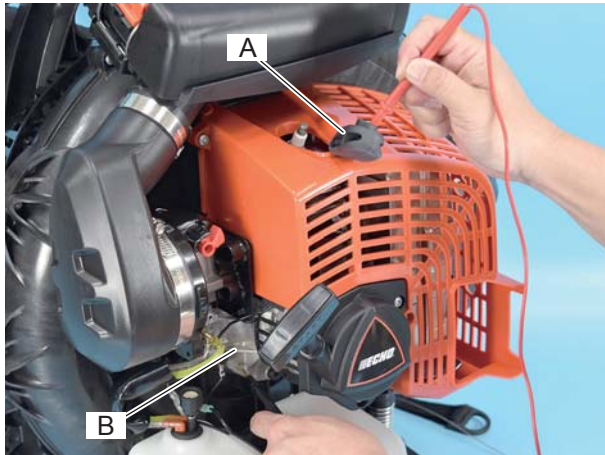

1. Connect Ohm-meter or Multimeter to spark plug cap coil (A) and crank case (B).

Secondary coil resistance: 785 - 1185 Ω

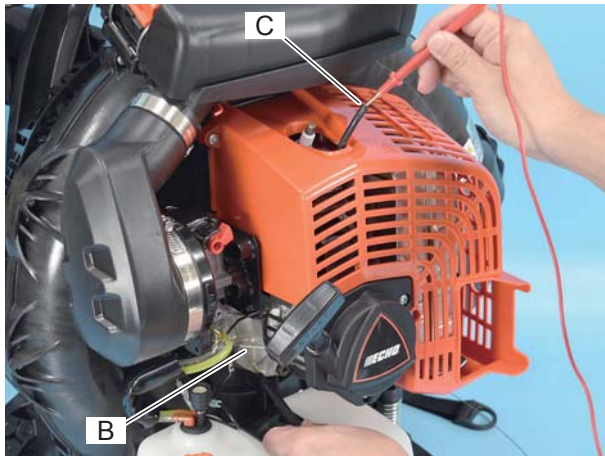

2. If the meter reading indicates infinite resistance, remove spark plug cap and spark plug cap coil, and measure resistance between the conduction wire of high tension lead (C) and crank case (B).

3. If the coil resistance is not in the spec. range, replace the ignition coil with new one. (Go to "3-8 Replacing ignition coil").

3-8 Replacing ignition coil

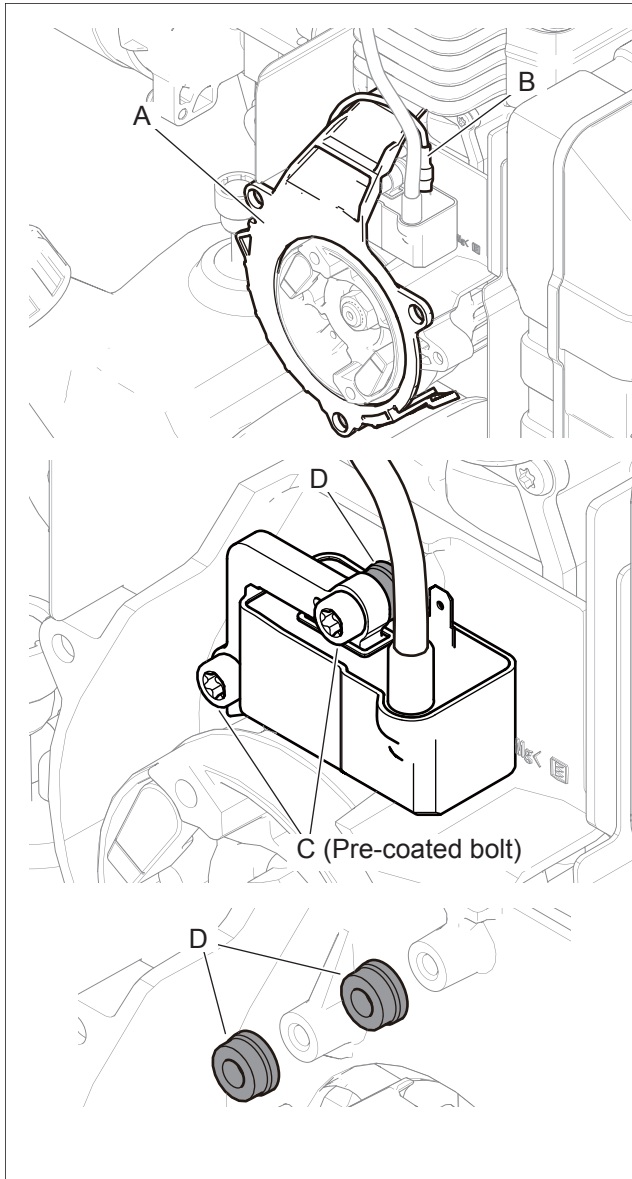
**Removing**

1. Remove engine cover and starter assembly.
2. Remove debris guard (A).
3. Disconnect primary wire (B) from ignition coil.

4. Loosen two bolts (C).

5. Remove ignition coil, taking care not to lose collars (D).

6. Remove spark plug cap and spark plug cap coil (Refer to "3-7 Replacing spark plug cap and coil").

Installing

1. Install spark plug cap and spark plug cap coil to new ignition coil.

2. Set collars (D), facing the flange side to the crankcase.

3. Loosely install new ignition coil with new pre-coated bolts.

4. Set pole shoe air gaps (Refer to "3-9 Setting pole shoe air gaps"). Tighten the bolts.

NOTE: When reusing two bolts (C), apply thread locking sealant ThreeBond #1344J. If old thread locking sealant is left in threads, correct torque may not be secured. In case old thread locking sealant is left, remove it.

3-9 Setting pole shoe air gaps

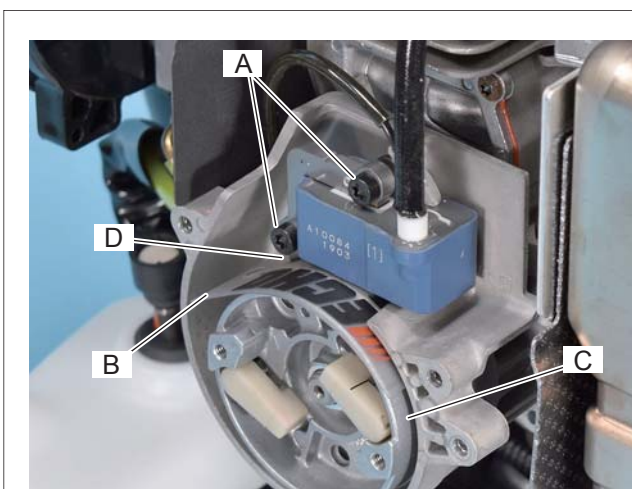
**Using Module air gap gauge 91004 (B)**

1. Loosen two bolts (A) and insert module air gap gauge (B) or 0.3 - 0.4 mm (0.012 - 0.016 in) thick feeler gauge between magneto rotor (C) and ignition coil shoes (D).

2. Rotate magneto rotor (C) until the magnetic poles face ignition coil shoes (D).

3. Hold ignition coil against magneto rotor (C) and tighten bolts (A). After tightening the bolts, remove module air gap gauge (B) or feeler gauge.

NOTE: When air gap is too narrow, contact with magneto rotor may result.

3-10 Inspecting and replacing magneto rotor

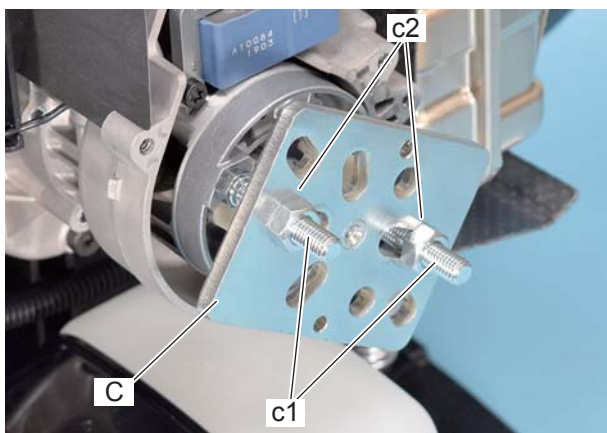
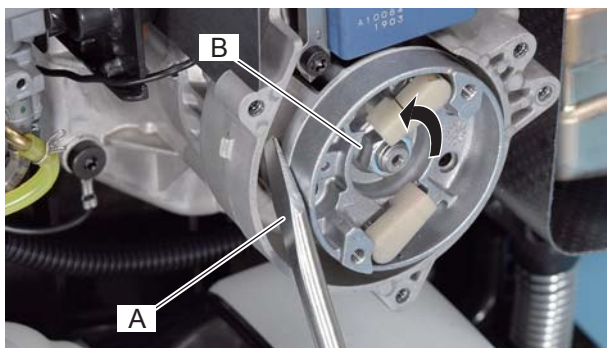

Inspecting

1. Inspect magnetic force of magneto rotor using flux meter, or flat head screwdriver (A) as shown.
2. If the magnetic force is weak, replace the magneto rotor with new one.

Removing

1. Remove spark plug.
2. Insert clean rope into spark plug hole to stop crankshaft rotation as shown.

NOTE: To avoid rope entering into cylinder port, do not insert rope end.

3. Remove nut (B) by rotating counterclockwise.

NOTE: Do not use power tool to remove the nut (B). Otherwise, piston damage may occur.

4. Set puller (C) on magneto rotor as shown.

NOTE: Bolts (c1) are screwed into the magneto rotor holes (D).

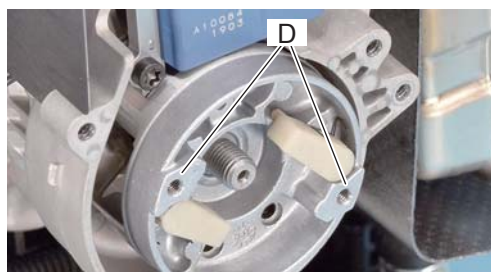

5. Tighten two nuts (c2) alternately and remove magneto rotor.

3-11 Inspecting and replacing woodruff key

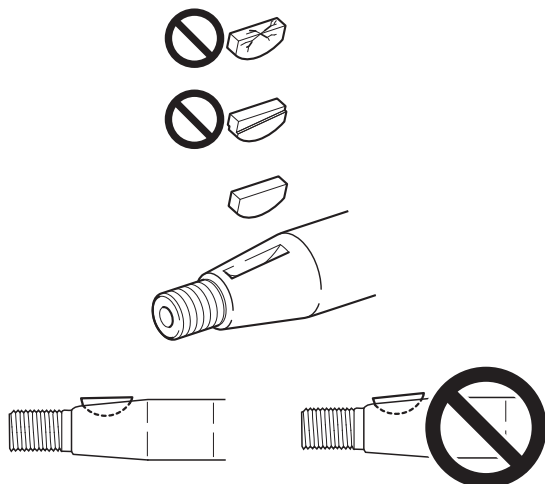

Inspecting

1. Inspect woodruff key for damage or shearing. Replace the key as required.

Installing

1. Wipe off oil from taper part of crankshaft.
2. Install woodruff key into the key groove.

NOTE: Align the woodruff key with the center line of the crankshaft.

4 FUEL SYSTEM

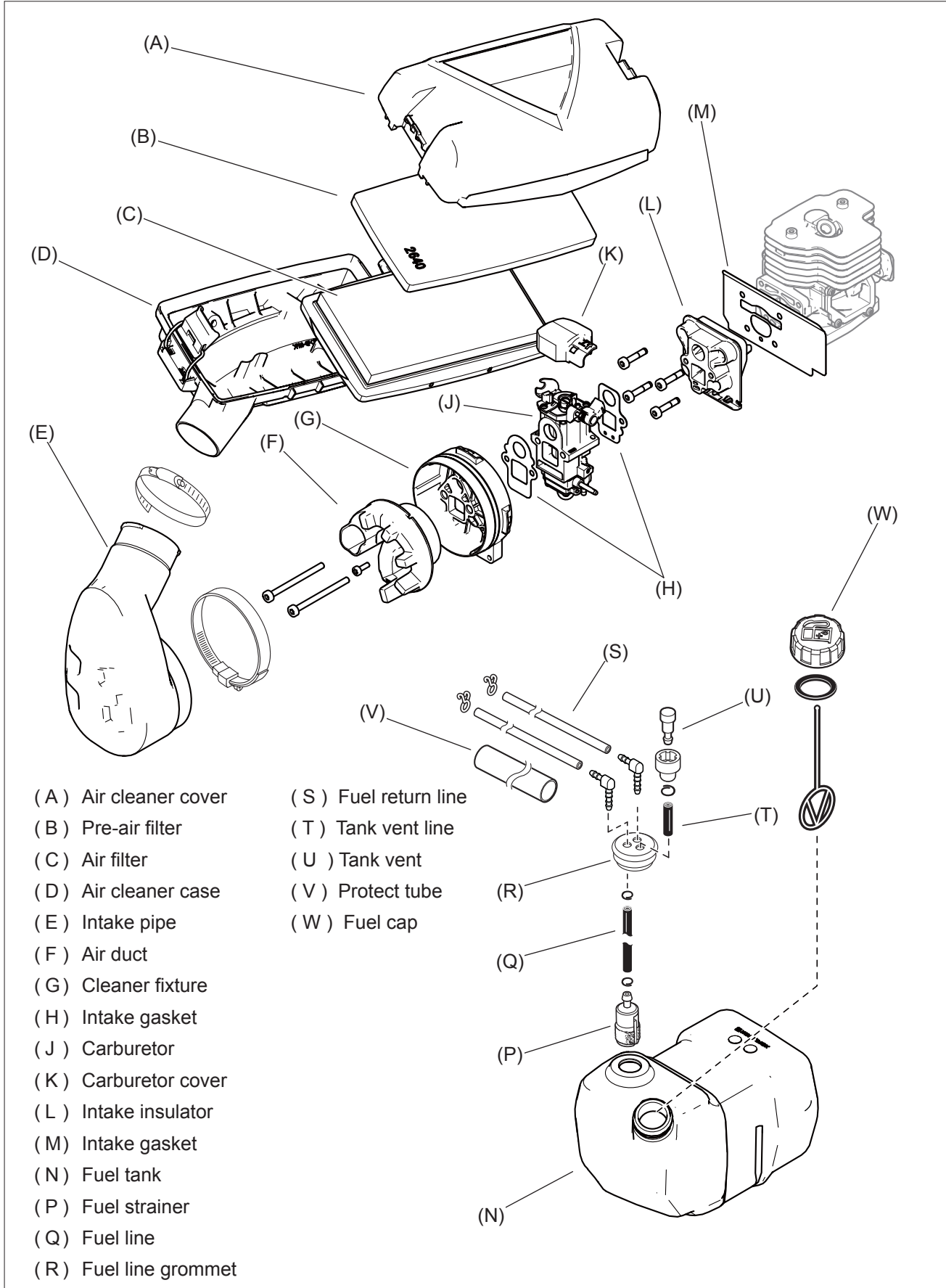

4-1 Inspecting air filter

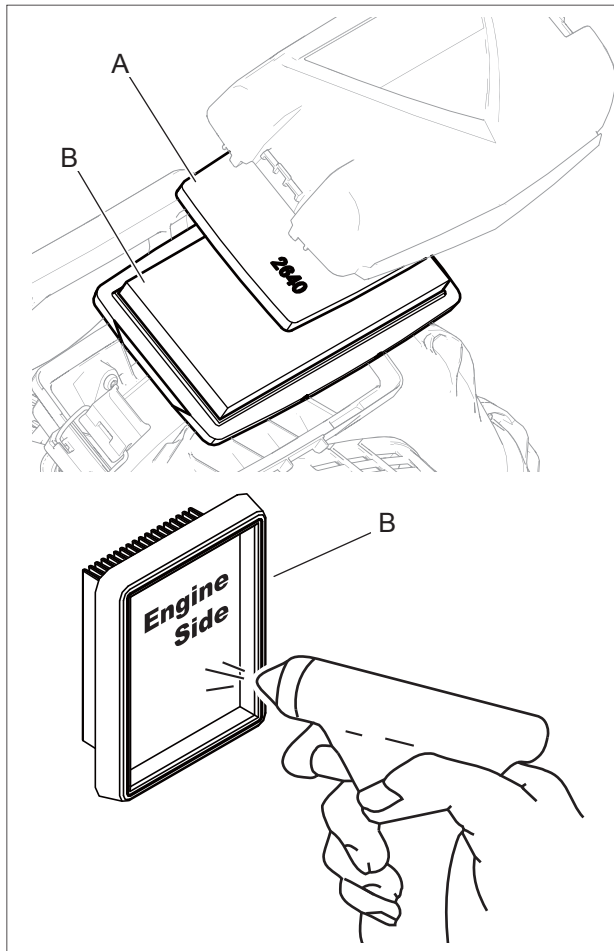

1. Remove air cleaner cover.
2. Remove pre-air filter (A) and air filter (B).
3. If pre-air filter (A) is dirty, wash the filter in a suitable cleaning solvent. Do not use compressed air.
4. If air filter (B) is dirty, clean the filter with compressed air or wash in a suitable cleaning solvent.

NOTE: Air filter should be dried completely after washing.

NOTE: To clean air filter with compressed air, blow dirt away carefully and thoroughly by widening the filter grooves.

WARNING  **DANGER**

Wear eye protection when working with compressed air. Eye damage can occur from flying particles.

5. If heavily soiled or damaged, replace air filters with new ones.

4-2 Inspecting fuel cap and fuel strainer

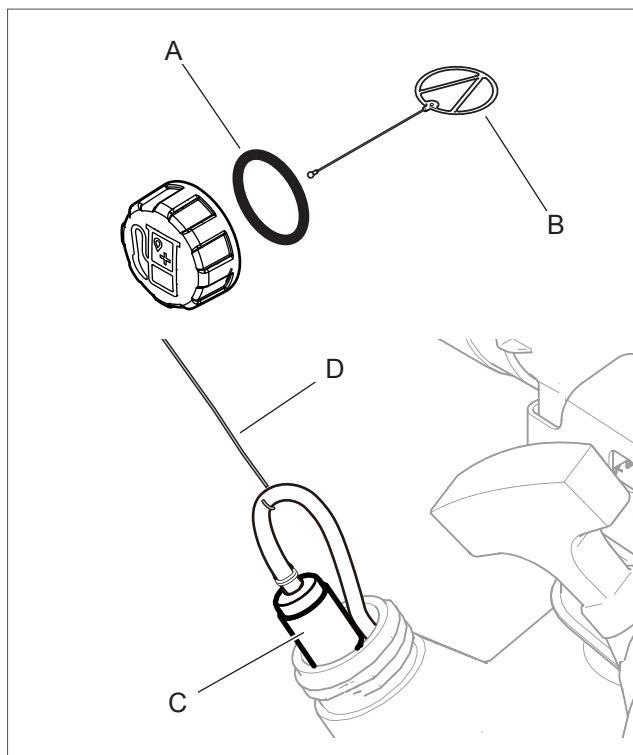

1. Remove fuel cap and inspect the cap for cracks.
2. Inspect Fuel cap gasket (A) and connector (B) for cuts or damage.
3. Replace them with new ones as required.

4. Pull out fuel strainer (C) from fuel tank using a wire hook (D).
5. Inspect fuel strainer (C).
6. Clean or replace as required.

4-3 Inspecting fuel tank and fuel line

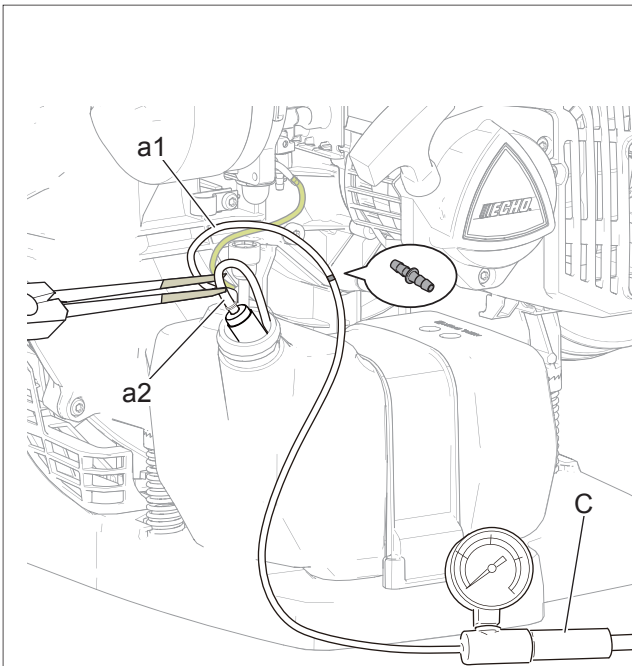
**Using Pressure tester 897803-30133 (C)**

1. Clean fuel tank inside as required.
2. Open fuel cap. Then, pull off outer fuel line (a1) from carburetor, pinching clip (B).

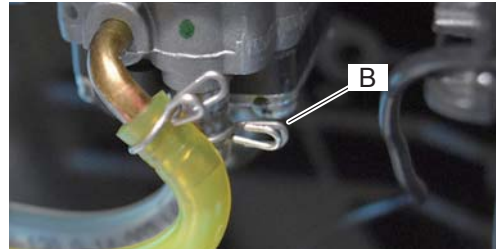

3. Connect pressure tester 897803-30133 (C) to outer fuel line (a1) with pipe joint V186-000510 (D).

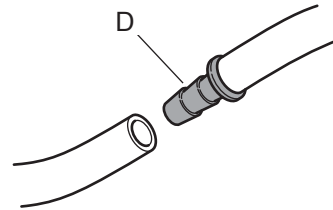

4. Remove fuel cap and pull out fuel strainer from fuel tank.
5. Pinch inner fuel line (a2) with longnose pliers to block air passage.

NOTE: Wrap the ends of the longnose pliers with tapes (or cover with soft pipes) to protect fuel line from damage.

6. Apply pressure approx. 0.05 MPa (0.5 kgf/cm²) (7 psi).
7. If the pressure drops, replace fuel line(s) (Refer to 4-4 Replacing fuel lines and grommet).

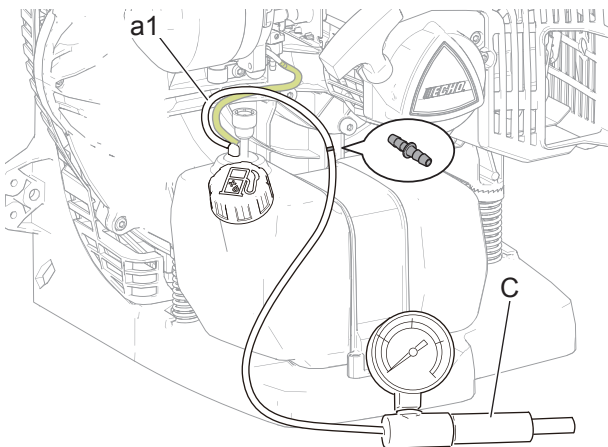

8. Put fuel strainer in fuel tank and fasten fuel cap securely.
9. Apply pressure approx. 0.01 MPa (0.1 kgf/cm²) (1.4 psi).
10. If the pressure drops, leakage may occur from fuel cap, fuel cap gasket, fuel tank, grommet, or tank vent.
11. Inspect and replace defective part(s) with new one(s).

4-4 Replacing fuel lines and grommet

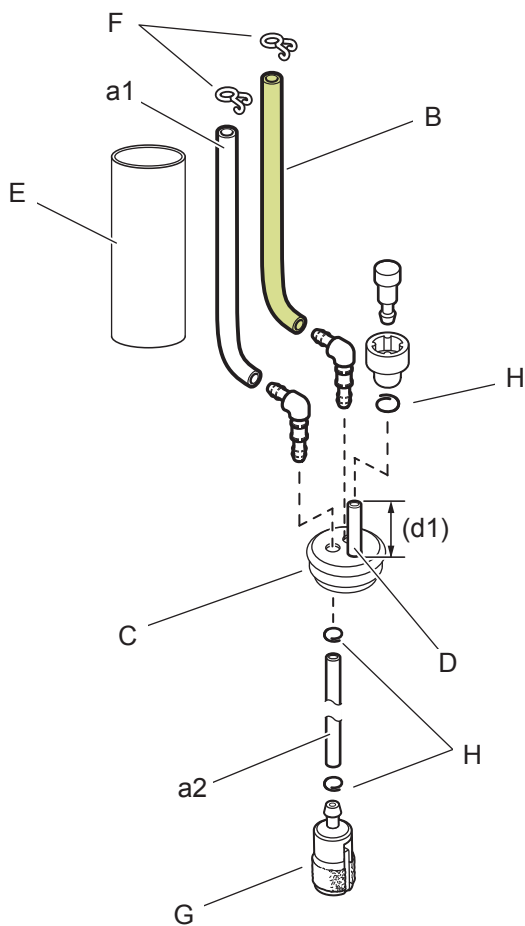
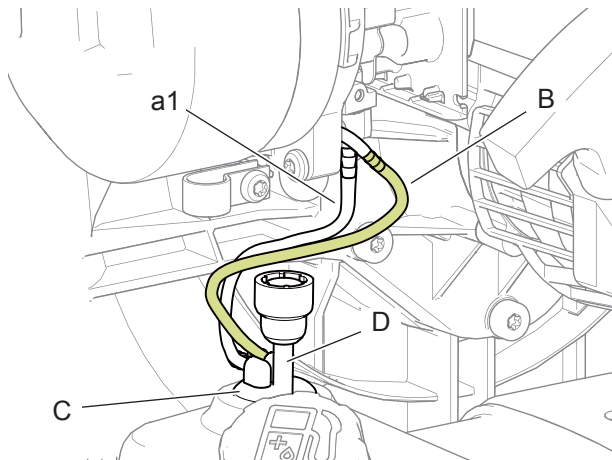
**Removing**

1. Open fuel cap. Then, pull off outer fuel line (a1) and fuel return line (B) from carburetor, pinching clips (F).
2. Remove fuel line grommet (C) from fuel tank, together with outer fuel line (a1), fuel return line (B) and tank vent line (D).

Fuel strainer can be directly pulled out through the grommet hole.

3. Remove fuel strainer (G) and inner fuel line (a2).
4. Remove protect tube (E).
5. Remove outer fuel line (a1), fuel return line (B) and tank vent line (D).
6. Inspect lines (a1), (a2), (B), (D) and grommet (C). Replace them if damaged.

Installing

1. Insert lines as shown.

Distance (d1): 15 mm (0.59 inch)

NOTE: Make sure outer fuel line (a1) and fuel return line (B) are inserted fully onto short nipple of pipe joints.

NOTE: Make sure tank vent line (D) and inner fuel line (a2) are secured with clips (H) as shown.

2. Cover outer fuel line (a1) and fuel return line (B) by protect tube (E).
3. Reinstall fuel grommet (C) to fuel tank, together with lines and fuel strainer (G).
4. Connect outer fuel line (a1) and fuel return line (B) to carburetor with clips (F).

4-5 Inspecting tank vent

NOTE: Tank vent prevents a vacuum from forming in fuel tank when fuel in fuel tank is being consumed. When pressure in fuel tank becomes too high, tank vent releases the pressure.

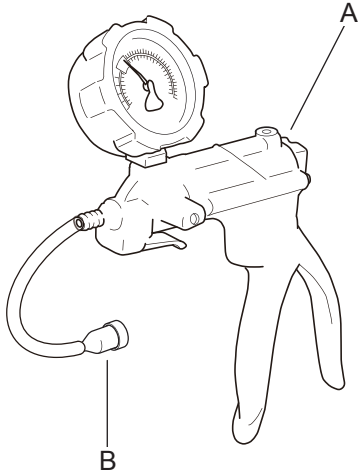
**Way1: Using Pressure / vacuum tester 91149 (A)**

1. Remove tank vent (B) from tank vent line and connect pressure / vacuum tester 91149 (A).
2. Apply pressure approx. 50kPa (0.5 kgf/cm²) (7 psi), make sure the pressure is stable in range of 10 - 40 kPa (0.1 - 0.4 kgf/cm²) (1.4 - 6psi).
3. If not, gently clean tank vent (B) with compressed air or replace with new one.
4. Apply negative pressure 20 kPa (0.2 kgf/cm²) (3 psi).
5. Tank vent should pass air freely without holding any pressure. If not, replace with new one.

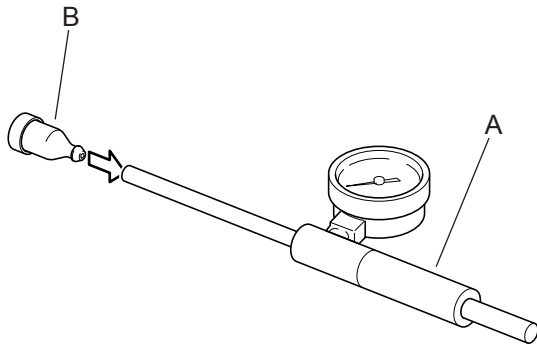
**Way2: Using Pressure tester 897803-30133 (A)**

1. Remove tank vent (B) from tank vent line and connect pressure tester 897803-30133 (A).
2. Apply pressure approx. 50 kPa (0.5 kgf/cm²) (7 psi), make sure the pressure is stable in range of 10 - 40 kPa (0.1 - 0.4 kgf/cm²) (1.4 - 6 psi).
3. If not, gently clean tank vent (B) with compressed air or replace with new one.

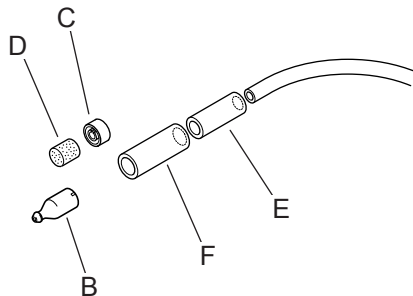

4. Remove cap (C) of tank vent (B), and clean sponge (D).

5. Cut pipe 363011-00210 (E: 7x11x170mm) and 382011-01110 (F: 9x13x350) in approx. 30mm (1 1/4 in) length, and connect them to pressure tester as shown. Connect tank vent (B) without cap to pipe as shown.

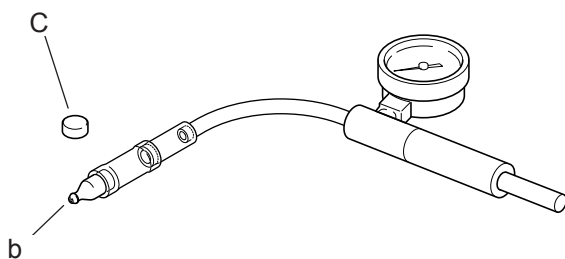

6. Plug hole (b) with finger and apply pressure 20 kPa (0.2 kgf/cm²) (3 psi). The pressure should hold steady.

7. Remove finger from hole (b). Tank vent should pass air freely without holding any pressure. If not, replace with new one.

4-6 Replacing carburetor

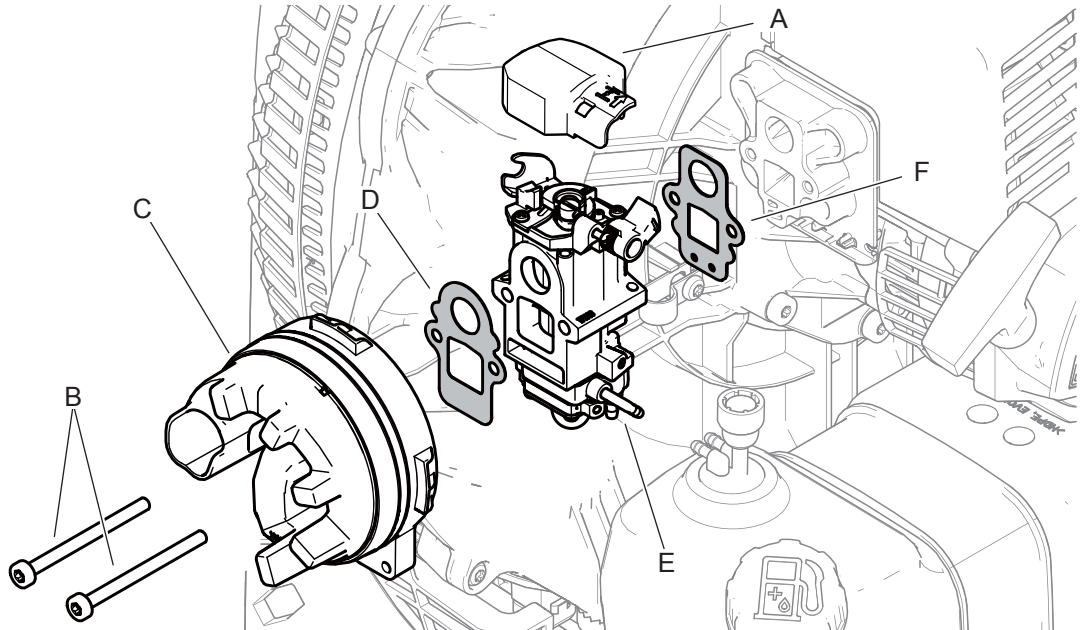
**Removing**

1. Remove intake pipe.
2. Remove carburetor cover (A).
3. Disconnect throttle cable from carburetor.
4. Pull off outer fuel line and fuel return line from carburetor.
5. Loosen two bolts (B) and remove air duct and cleaner fixture (C), intake gasket (D) and carburetor (E) from the unit.

Installing

1. Install new intake gasket (F).
2. Install carburetor (E).
3. Install new intake gasket (D).

NOTE: Two intake gaskets (D) and (F) are not same, take care not to mix the gaskets.

4. Reassemble all removed parts.

4-7 Testing carburetor

NOTE: To perform this test, carburetor interior should be wet with fuel.

If dry, a little leakage may occur from diaphragms and/or inlet needle seat.

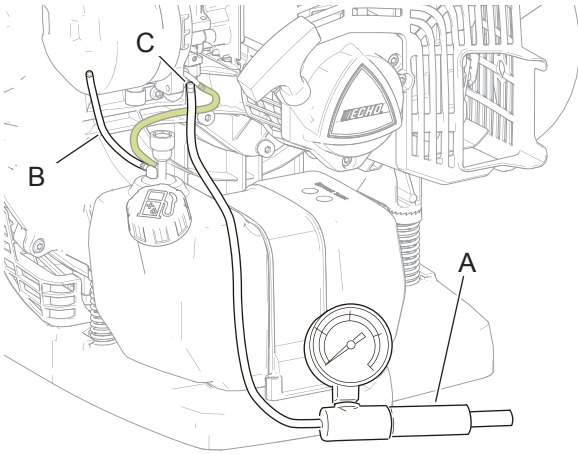
**Using Pressure tester 897803-30133 (A)**

1. Open fuel cap. Then, pull off outer fuel line (B) from carburetor.

2. Connect Pressure tester 897803-30133 (A) to carburetor fuel inlet (C).

3. Apply pressure approx. 100 kPa (1.0 kgf/cm²) (14 psi).

4. If the pressure remains steady, follow step 5 and 6. If the pressure drops, proceed to step 7.

5. Lightly push purge bulb. The pressure tester reading should drop and remain above 50 kPa (0.5 kgf/cm²) (7 psi).

6. If the reading does not drop, inspect inlet needle valve for sticking or metering lever height.

7. If the pressure drops at step 3, or if the pressure drops below standard figure at step 5, remove carburetor from the unit (Refer to "4-6 Replacing carburetor").

8. Submerge carburetor in suitable clean solvent to locate the leak by applying pressure approx. 100 kPa (1.0 kgf/cm²) (14 psi).

9. If air bubbles come out between pump body (d1) and carburetor body (d2), inspect pump diaphragm, pump gasket, and diaphragm seat of carburetor body (Refer to "4-11 Inspecting diaphragm and others").

10. If air bubbles come out from throttle bore (d3), inspect inlet needle valve, metering lever spring, and metering lever height (Refer to "4-10 Inspecting inlet needle valve" and "4-9 Inspecting metering lever height").

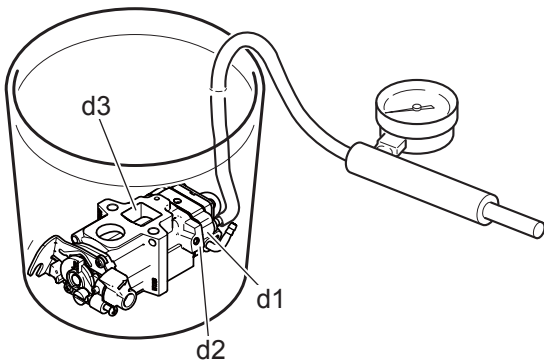

4-8 Inspecting crankcase pulse passage

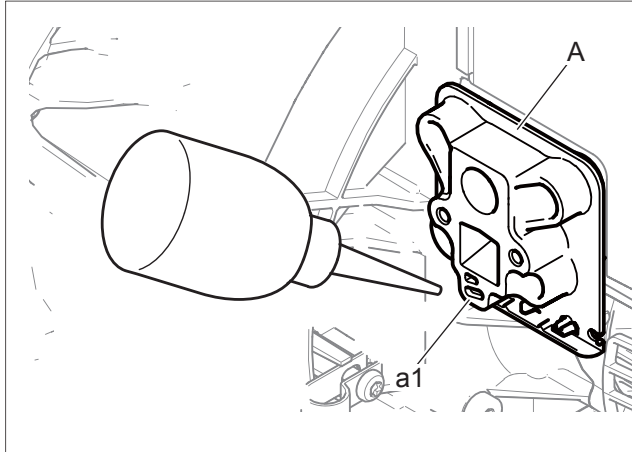

1. Remove carburetor and drop a little oil in pulse hole (a1) on intake insulator (A).
2. Remove spark plug and pull starter grip several times. The oil should spit back from the hole (a1).
3. If not, inspect whether pulse passage is clogged.
4. Clean or replace as required.

4-9 Inspecting metering lever height

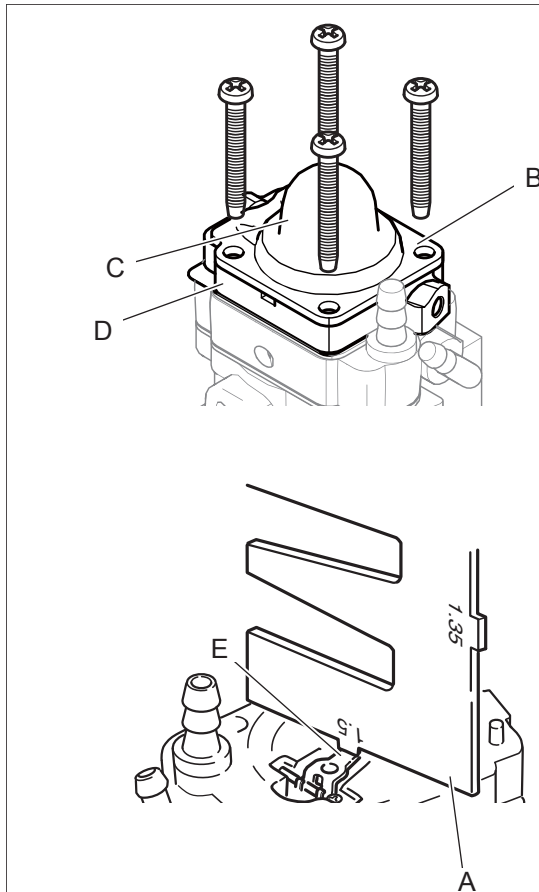

Using Metering lever gauge 897563-19830 (A)

1. Remove carburetor.
2. Remove four screws, pump cover (B), purge bulb (C), air purge body (D), metering diaphragm and metering diaphragm gasket.
3. Inspect metering lever (E) height using metering lever gauge (A).
4. If necessary, gently bend the lever (E) up or down to set the lever (E) at proper position of 1.5 mm (0.06 in).

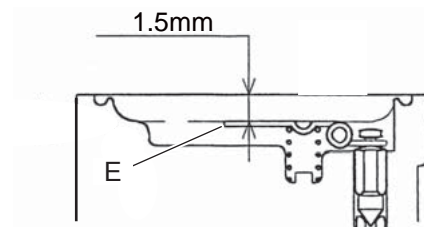

NOTE: When metering lever is:

- Too high → Fuel flooding occurs
- Too low → Fuel starvation / overheating occurs

4-10 Inspecting inlet needle valve

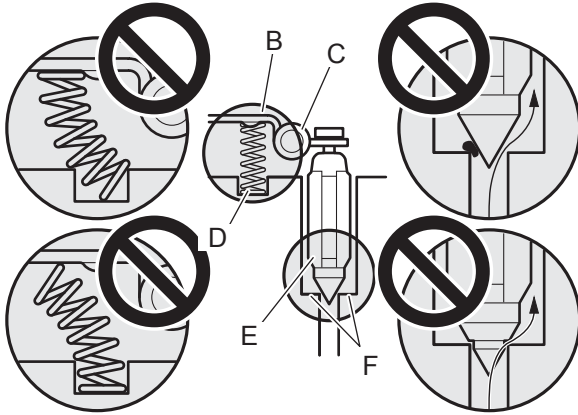
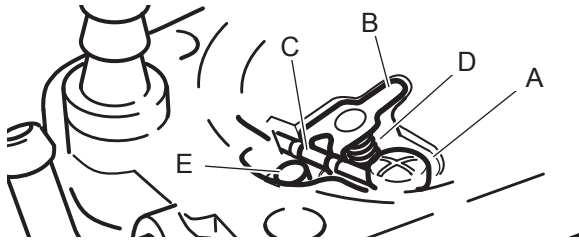

1. Loosen screw (A) and remove metering lever (B), metering lever pin (C), metering lever spring (D) and inlet needle valve (E).

2. Inspect inlet needle valve (E) if worn or sticky. Clean or replace as required.

3. Clean inlet needle valve seat (F) using suitable clean solvent (Do not use metal tools).

NOTE: Causes of fuel flooding from carburetor to cylinder are as follows:

- Improper assembling of metering lever (B) and spring (D).
- Dirt between inlet needle valve (E) and valve seat (F)
- Worn inlet needle valve tip.

4. Reassemble inlet needle valve (E), spring (D), metering lever (B) and metering lever pin (C).

NOTE: To verify proper metering lever installation, check the following:

- (1) Spring (D) is seated in its hole at chamber floor.
- (2) Spring (D) is under dimple of metering lever.
- (3) Metering lever fork is holding inlet needle valve (E).

5. Inspect metering lever height (Refer to "4-9 Inspecting metering lever height").

4-11 Inspecting diaphragm and others

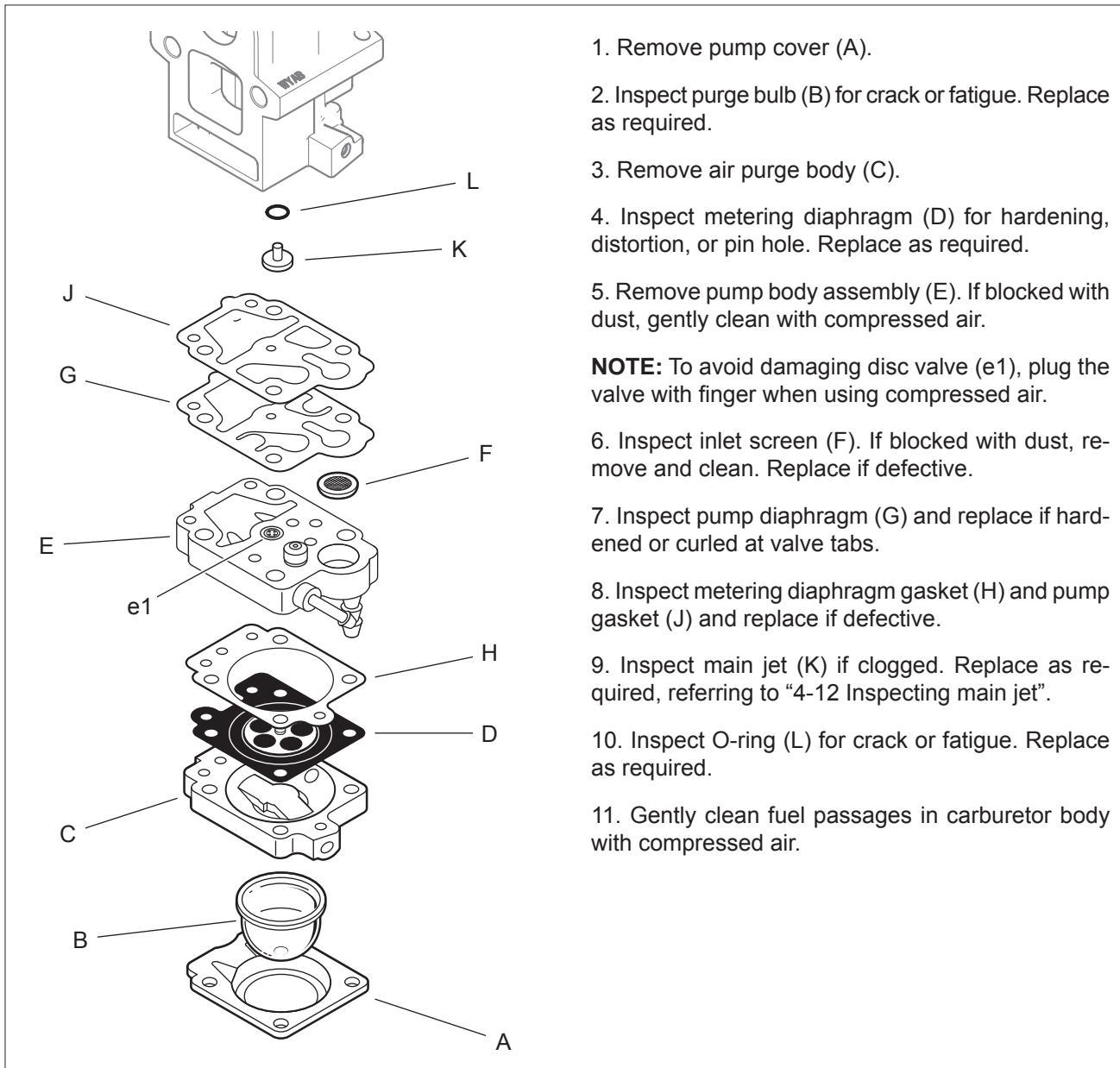

1. Remove pump cover (A).
 2. Inspect purge bulb (B) for crack or fatigue. Replace as required.
 3. Remove air purge body (C).
 4. Inspect metering diaphragm (D) for hardening, distortion, or pin hole. Replace as required.
 5. Remove pump body assembly (E). If blocked with dust, gently clean with compressed air.
- NOTE:** To avoid damaging disc valve (e1), plug the valve with finger when using compressed air.
6. Inspect inlet screen (F). If blocked with dust, remove and clean. Replace if defective.
 7. Inspect pump diaphragm (G) and replace if hardened or curled at valve tabs.
 8. Inspect metering diaphragm gasket (H) and pump gasket (J) and replace if defective.
 9. Inspect main jet (K) if clogged. Replace as required, referring to "4-12 Inspecting main jet".
 10. Inspect O-ring (L) for crack or fatigue. Replace as required.
 11. Gently clean fuel passages in carburetor body with compressed air.

4-12 Inspecting main jet

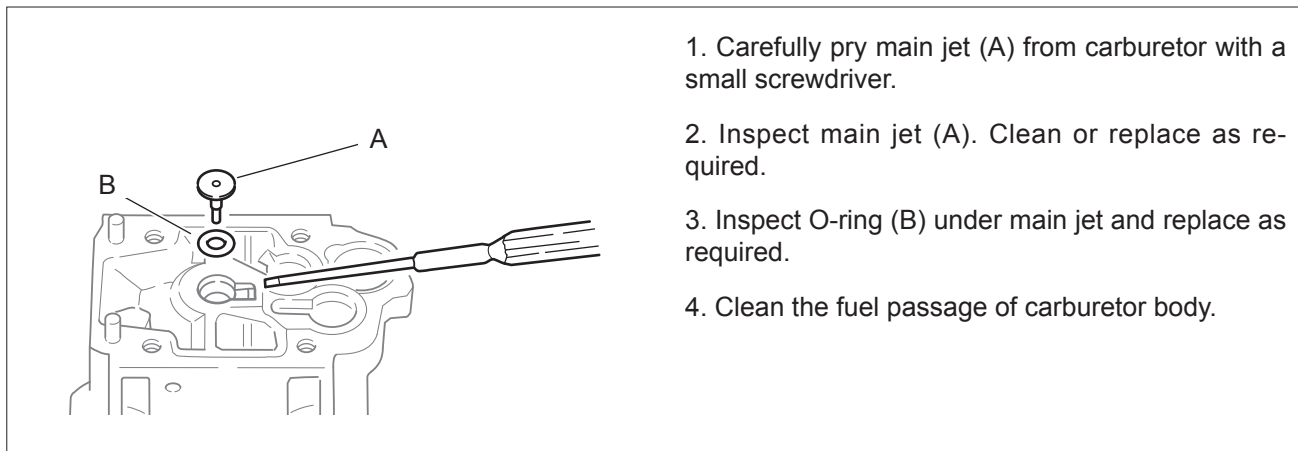

1. Carefully pry main jet (A) from carburetor with a small screwdriver.
2. Inspect main jet (A). Clean or replace as required.
3. Inspect O-ring (B) under main jet and replace as required.
4. Clean the fuel passage of carburetor body.

4-13 Adjusting carburetor

4-13-1 General adjusting rules

A. Before adjustment, check the following items.

1. The correct spark plug must be clean and properly gapped.
2. The air filters must be clean and properly installed.
3. The muffler exhaust port must be clear of carbon.
4. The fuel lines, tank vent and fuel strainer are in good condition and clear of debris.
5. The fuel is fresh (> 89 octane : RON) and properly mixed at 50 : 1 with "ISO L-EGD" or "JASO FC/FD" 2-stroke oil.
6. All blower pipes are installed for proper engine loading.

B. Preliminary adjustment : Adjustment by Throttle adjust screw of carburetor.

Start and run engine for 30 seconds at idling and then run for 180 seconds at WOT (wide open throttle). Verify idle engine speed ranges from 2,300 to 2,700 r/min, and WOT engine speed is over 7,500 r/min. If idle engine speed is out of range, adjust throttle adjust screw to 2,300 - 2,700 r/min. Make sure WOT engine speed is over 7,500 r/min again. If engine does not run correctly after this adjustment, proceed to the next step 6-6-2.

4-13-2 Initial setting Throttle adjust screw, L mixture needle and H mixture needle

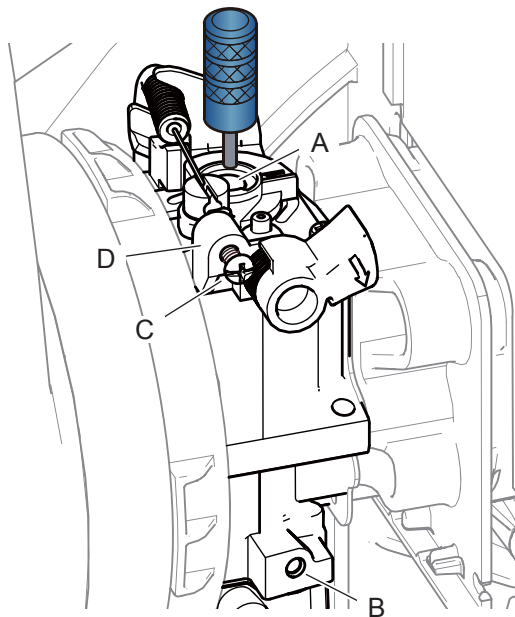
**Tools required:**

- Tachometer PET-1000R P/N 897802-33330
- Short type D-shaped tool(S) P/N 91159S

1. Remove carburetor cover.
2. Turn L and H mixture needles clockwise until lightly seated, and then turn out both mixture needles following turns.

L mixture needle (A): 2 1/2

H mixture needle (B): 1 3/4

NOTE: If needles are overtightened during seating, damage to carburetor may occur.

3. Turn Throttle adjust screw (C) clockwise until its head touches boss (D). Then turn Throttle adjust screw (C) counterclockwise 9 1/4 turns.

NOTE: The initial carburetor settings for Throttle adjust screw, L and H mixture needles are intended to start and run the engine before final carburetor adjustments are made through this procedure. The actual number of turns needed for engine operation may vary.

4-13 Adjusting carburetor (continued)

4-13-3 Adjusting carburetor

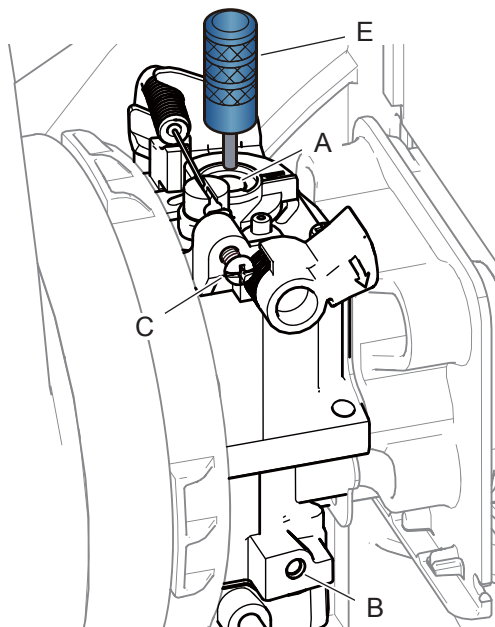

1. Start and run engine for 30 seconds at idling and then run for 180 seconds at WOT.

2. Adjust L mixture needle (A) using Short type small D-shaped tool (E) to reach maximum engine speed just before lean drop off.

3. Set idle speed to 2,900 r/min by turning Throttle adjust screw (C). The engine speed should be stable at 2,900 +/- 50 r/min.

4. Turn L mixture needle (A) counterclockwise to reduce idle speed 400 r/min to set idle speed at 2,500 r/min. The idle speed range is 2,300 - 2,700 r/min.

NOTE: Engine speed must be allowed to stabilize a minimum of 20 seconds after each adjustment of L mixture needle to assure accurate tachometer readings.

5. Adjust H mixture needle (B) to obtain maximum WOT engine speed just before lean drop off using Short type small D-shaped tool (E).

6. Turn H mixture needle (B) counterclockwise to reduce WOT engine speed 60 - 80 r/min.

7. Stop and restart engine, and verify engine idle speed ranges from 2,300 to 2,700 r/min, and WOT engine speed is over 7,500 r/min.

When final adjustment is completed, the engine should idle, accelerate smoothly, and attain WOT per above specification.

4-14 Checking and adjusting throttle cable

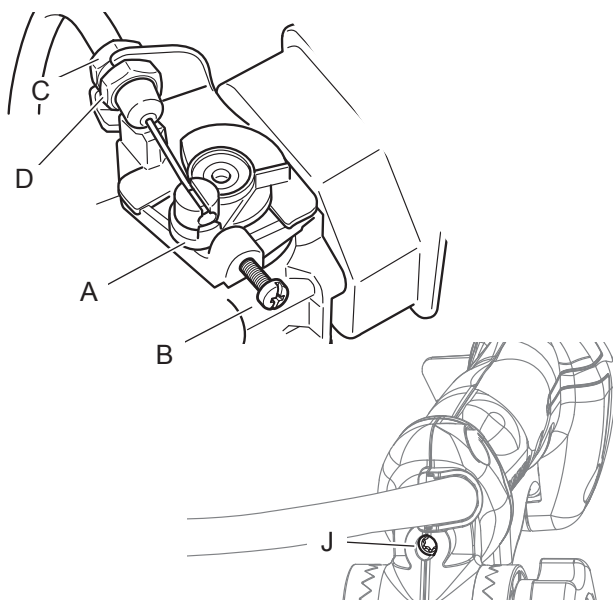

1. Confirm throttle plate (A) contacts tip of Throttle adjust screw (B) when throttle trigger is in idling position.

2. Make sure carburetor becomes WOT (wide open throttle) when throttle trigger is fully squeezed.

3. If result of 1 and 2 is not sufficient, loosen nut (C) and adjust nut (D) to obtain correct position and movement.

4. After confirming throttle cable inner wire moves smoothly when throttle trigger is squeezed, fasten nut (C) to fix outer throttle cable.

NOTE: Throttle cable can be adjusted by turning bolt (J) in handle grip.

5 BACKPACK FRAME

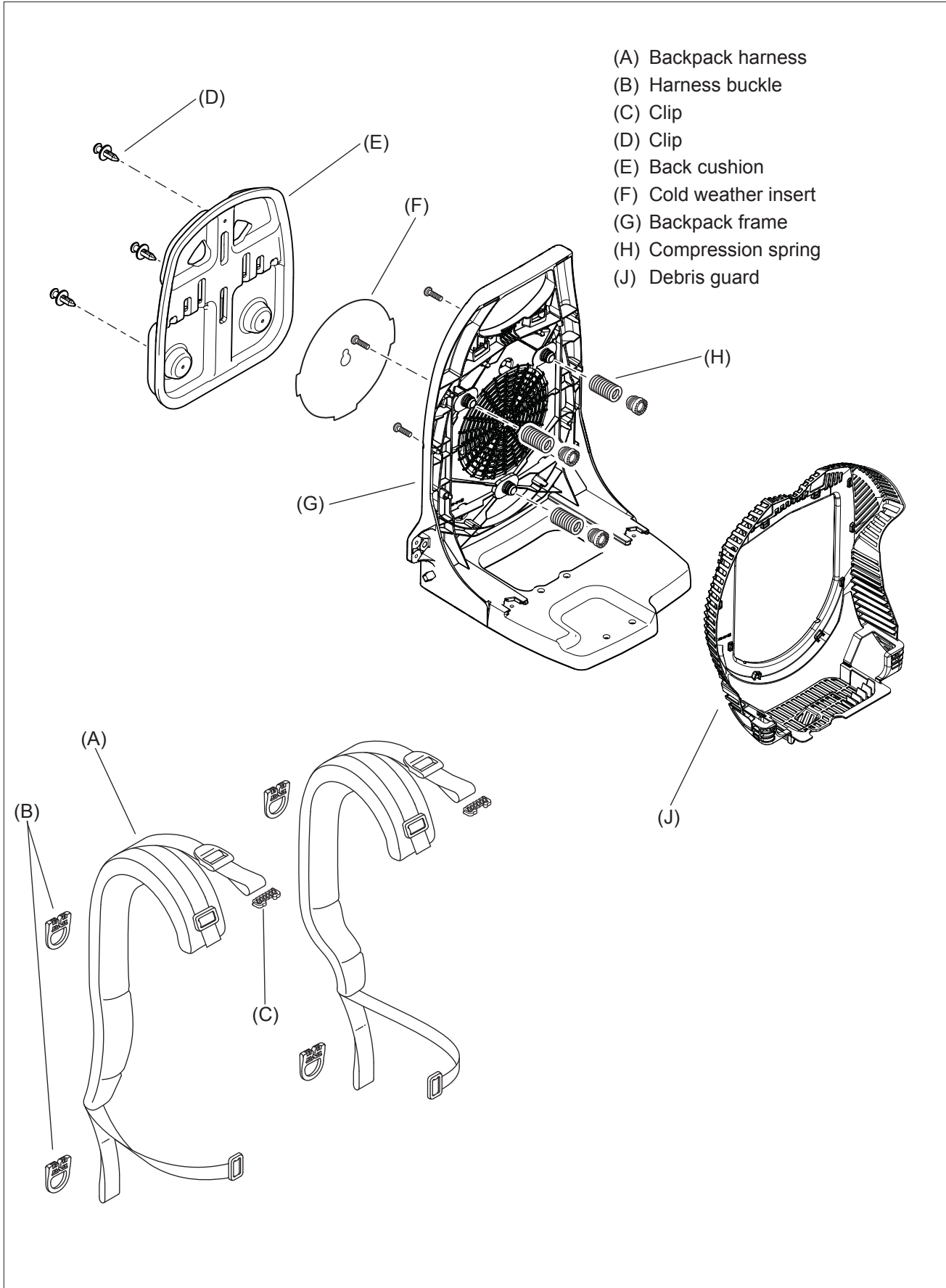

5-1 Removing backpack frame assembly

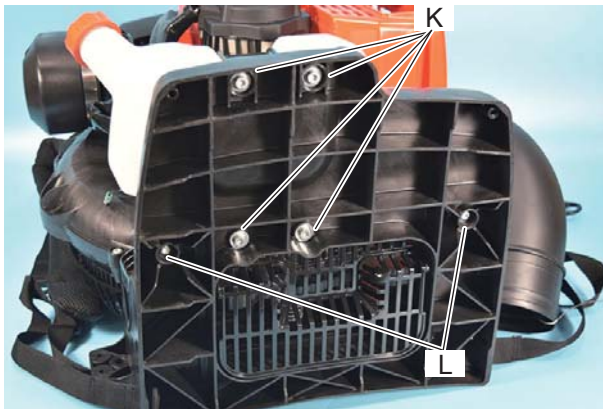

1. Remove four precoated bolts (K) and washers.

NOTE: When retighten the precoated bolts (K), replace new ones or apply thread locking sealant ThreeBond #1324N.

If old thread locking sealant is left in threads, correct torque may not be secured. In case old thread locking sealant is left, remove it.

2. Remove two tapping bolts (L).



3. Pull up head of clip (M) as shown to remove the clip.

4. Remove back cushion (E) from backpack frame.

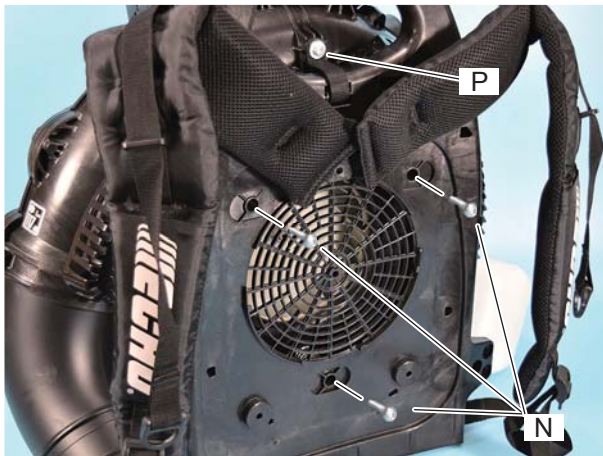

5. Remove three tapping bolts (N).

6. Remove bolt (P).

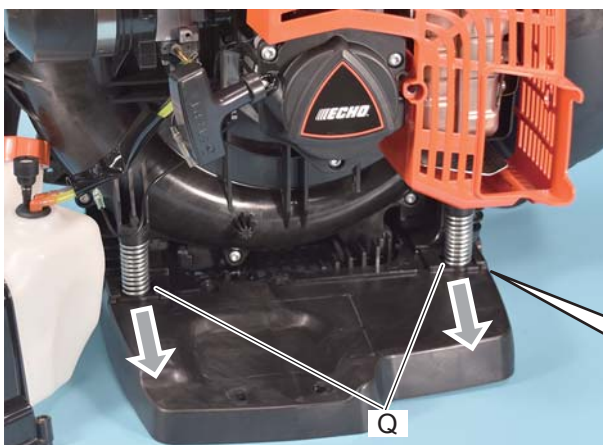

7. Remove fuel tank band and fuel tank.

8. Slide spring holders (Q) forward as shown to remove fan case assembly from backpack frame assembly.

NOTE: Spring holders (Q) easily slide out of backpack frame slots.



5-2 Replacing backpack harness



1. Remove backpack frame assembly (Refer to “5-1 Removing backpack frame assembly”).
2. Remove backpack harness from backpack frame.
3. Insert upper harness buckle (R) into hole of backpack frame.

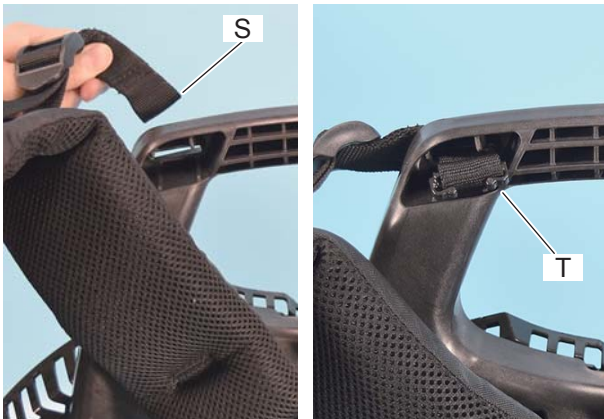

4. Insert harness strap (S) into hole of backpack frame.
5. Attach clip (T) to harness strap (S) as shown.

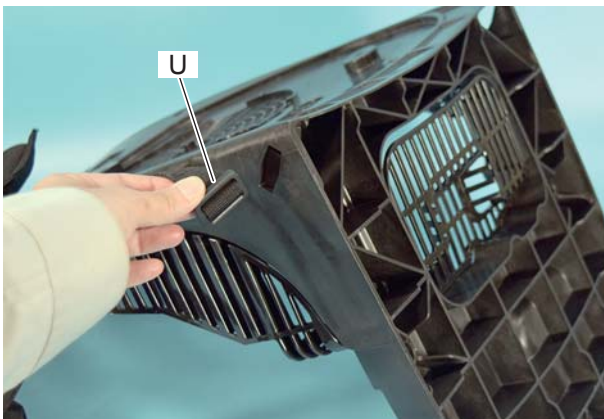

6. Insert lower harness buckle (U) into hole of backpack frame.



7. Attach two harness buckles (V) to harness strap as shown.

5-3 Replacing backpack frame, debris guard and spring

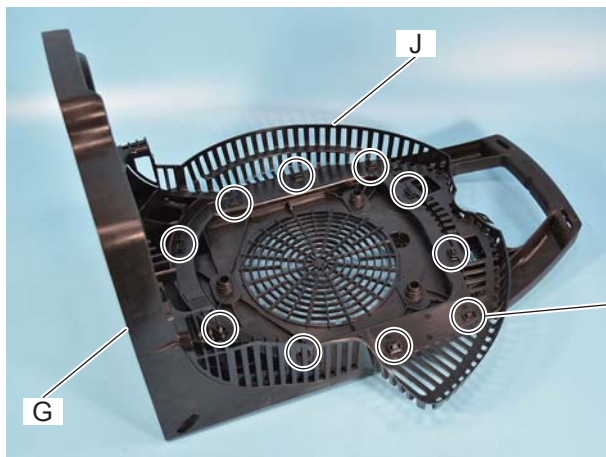

1. Remove backpack frame assembly (Refer to “5-1 Removing backpack frame assembly”).

2. Detach debris guard (J) from ten tabs on backpack frame (G).

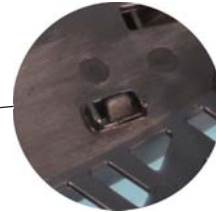

3. When assembling debris guard (J) and backpack frame (G), make sure ten tabs on backpack frame (G) are fully engaged with holes on debris guard (J).

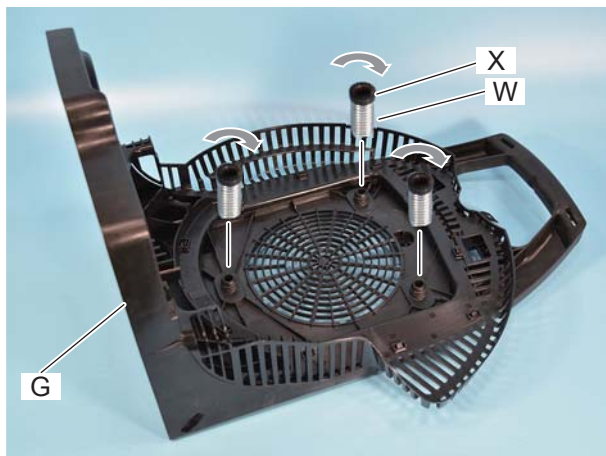

4. When replacing spring (W), assemble spring (W) and spring holder (X) and then install spring (W) to backpack frame (G).

5. Reassemble removed parts (Refer to “5-1 Removing backpack frame assembly”).

6 BLOWER SYSTEM

- (A) Engine side fan case
- (B) Guard side fan case
- (C) Elbow
- (D) Fan
- (E) Engine plate
- (F) Spacer
- (G) Anti-static lead
- (H) Spring
- (J) Spring holder

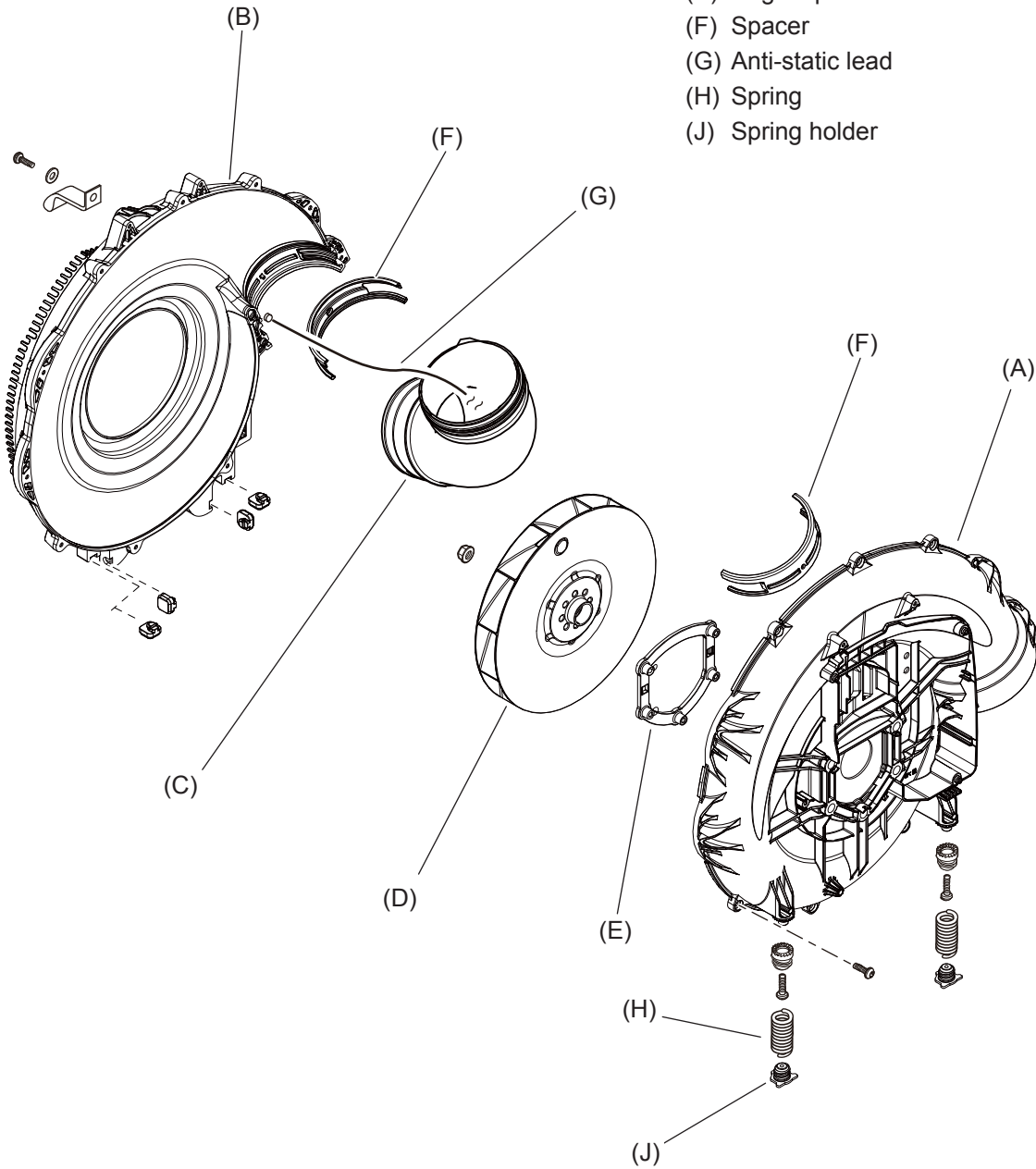

6-1 Separating fan case assembly

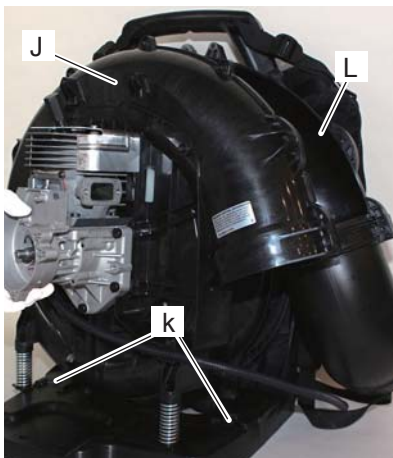
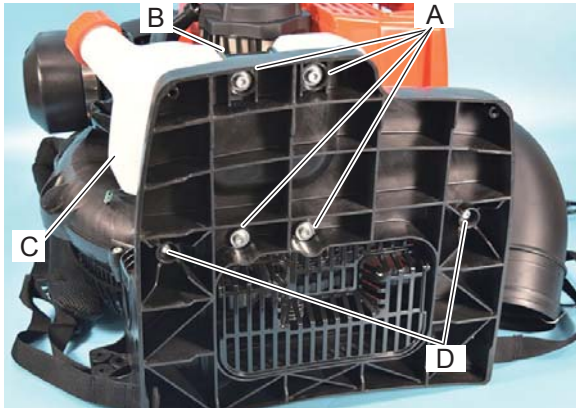

1. Loosen four precoated bolts (A) and washers to remove fuel tank band (B) and fuel tank (C) (Refer to “5-1 Removing backpack frame assembly”).

2. Remove two tapping bolts (D) holding spring (E) and spring holders (F). Spring holders (F) easily slide out of backpack frame slots (k).

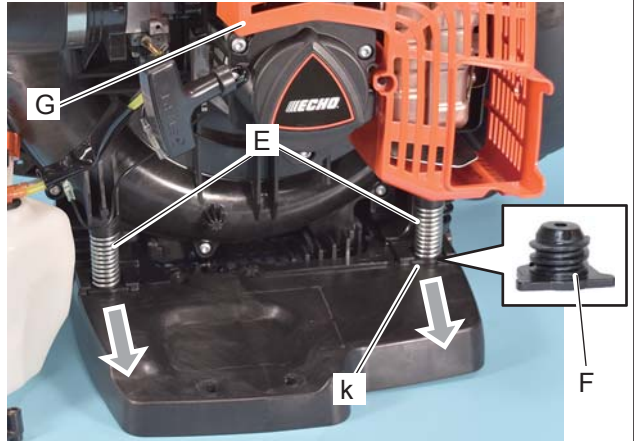

3. Remove engine cover (G) and air cleaner case (H).

4. Loosen 11 tapping bolts to separate fan case assembly.

5. Remove engine side fan case (J) from guard side fan case (L).

6-2 Replacing elbow

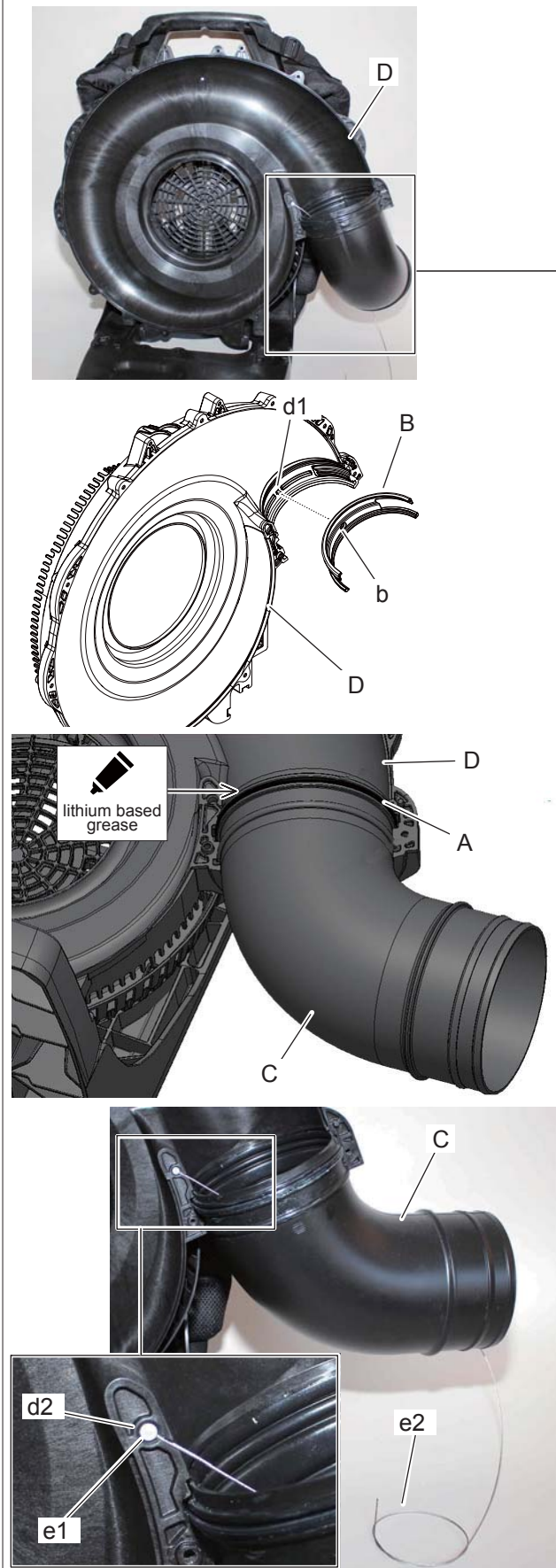

1. Remove engine side fan case from guard side fan case (D) (Refer to “6-1 Separating fan case assembly”).

2. Remove end (e1) of anti-static lead.

3. Remove elbow (C) with O-ring (A) from guard side fan case (D).

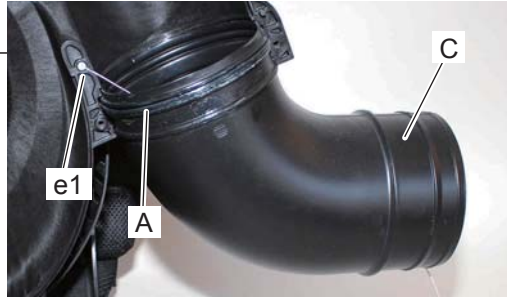

4. Replace elbow, O-ring and anti-static lead if defective.

5. Assemble spacer (B) and guard side fan case (D).

NOTE: Insert projection (d1) of guard side fan case (D) in hole (b) of spacer (B).

6. Insert O-ring (A) to elbow (C) and apply lithium based grease to all around O-ring (A) lightly.

7. Insert elbow (C) with O-ring (A) to guard side fan case (D).

8. Set end (e1) of anti-static lead in guard side fan case slot (d2) certainly, through elbow (C).

9. Wind the other end (e2) of anti-static lead several times.

6-3 Disassembling and assembling fan

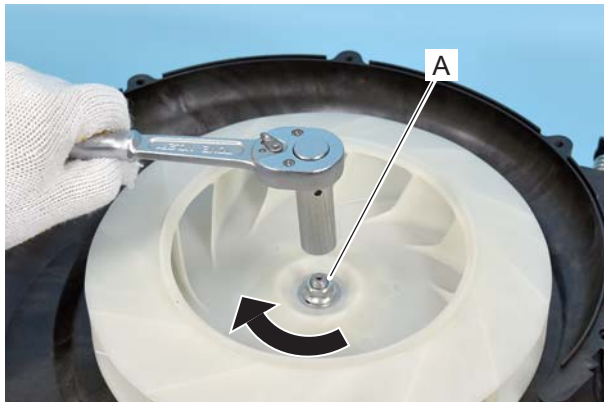
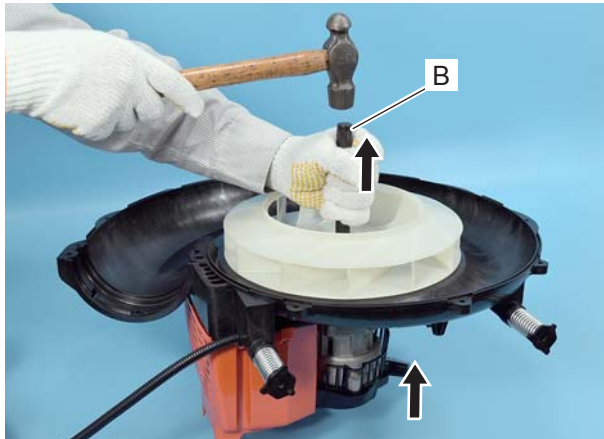
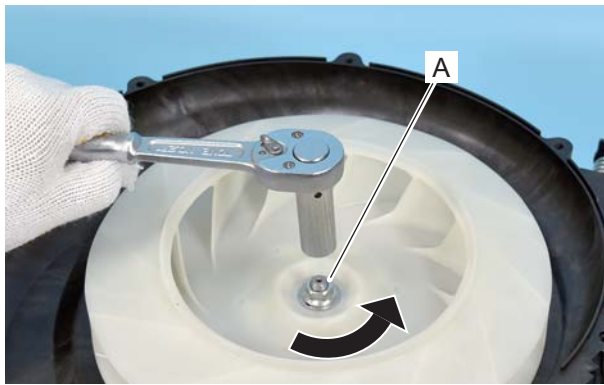

1. Install clean rope into spark plug hole (Refer to "3-10 Inspecting and replacing magneto rotor").

2. Remove fan nut (A) using 14mm socket wrench counterclockwise.

3. Thread Fan remover 91087 (B) on crankshaft end.

4. Lift up Fan remover (B).

5. Strike the end of Fan remover 91087 (B) with a hammer squarely as shown.

6. Replace fan if defective.

7. Tighten fan nut (A) using 14mm socket wrench clockwise.

6-4 Replacing fan case

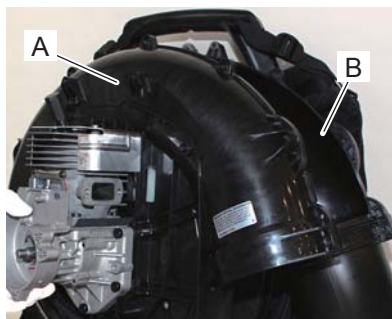

1. Remove engine side fan case (A) from guard side fan case (B) (Refer to "6-1 Separating fan case assembly").

2. Replace guard side fan case if defective (Refer to "5-1 Removing backpack frame assembly").

3. When removing engine from engine side fan case (A), remove fan from engine side fan case (A) first. Then loosen five bolts.

4. Replace engine side fan case if defective.

6-4 Replacing fan case (continued)

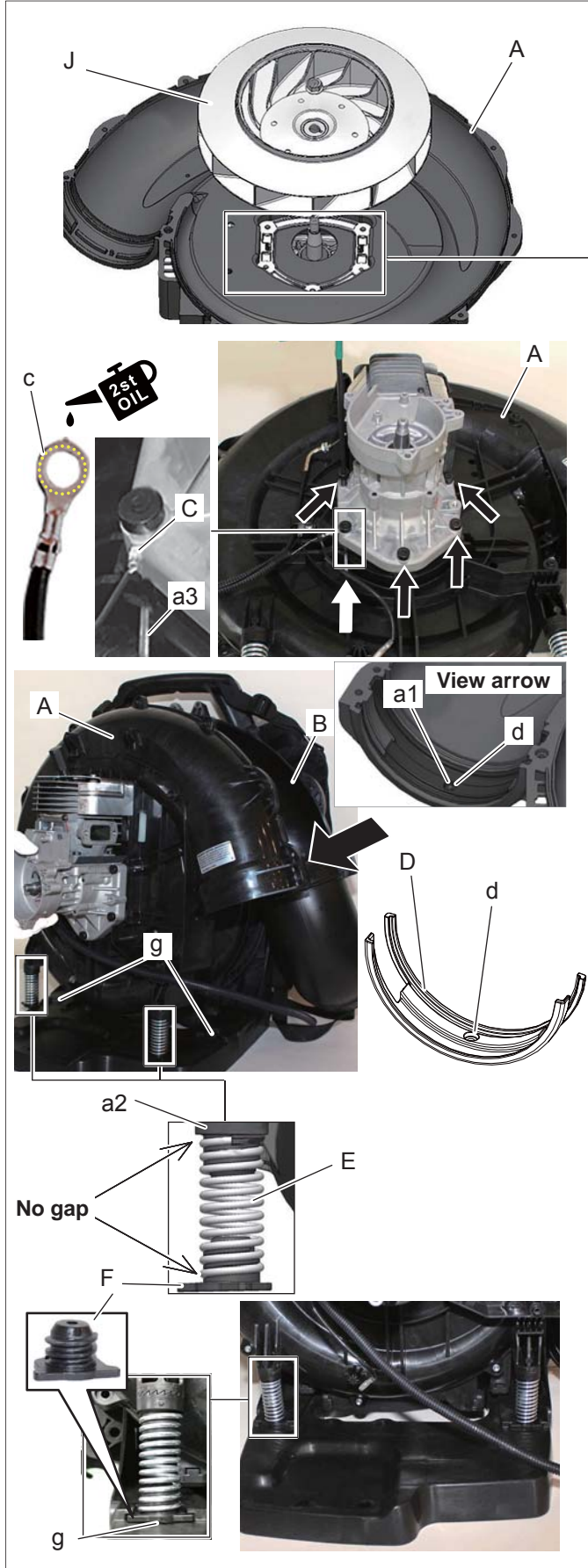

Assembling fan case

5. Place engine plate (H) and fan (J) on engine side fan case (A).

6. Hook nails parts of engine side fan case (A) on engine plate (H) as shown.

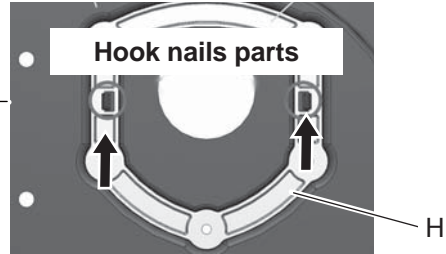

7. Assemble fan and engine side fan case (A) (Refer to "6-3 Disassembling and assembling fan").

8. When installing engine on engine side fan case (A) with five bolts, fasten stop switch ground lead (C) shown as white arrow.

NOTE: Apply 2-stroke oil on stop switch ground lead (c:yellow dotted line) and fasten stop switch ground lead (C) in parallel with projection (a3).

9. Make sure projection (a1) of engine side fan case (A) is inserted in hole (d) of spacer (D).

10. Install springs (E) and spring holders (F) to engine side fan case (A).

NOTE: Joint of springs (E) and engine side fan case (a2) should be no gap. Joint of springs (E) and spring holders (F) should be no gap.

11. Assemble engine side fan case (A) and engine to guard side fan case (B).

12. Slide and insert spring holders (F) into slots (g) on backpack frame.

13. Tighten 11 tapping bolts in order shown.

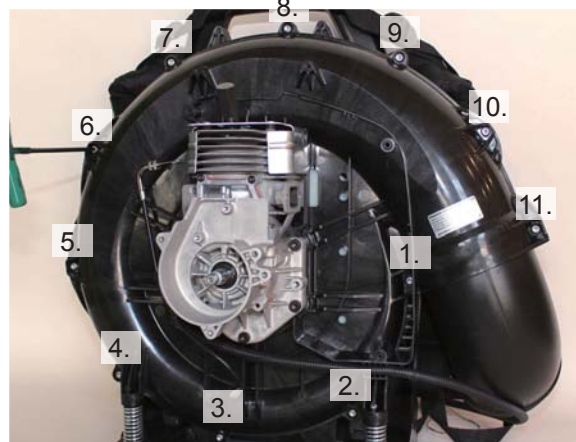

14. Reassemble all removed parts (Refer to "6-1 Separating fan case assembly").

7 ENGINE

- (A) Cylinder
- (B) Cylinder gasket
- (C) Piston ring
- (D) Piston
- (E) Snap ring
- (F) Needle bearing
- (G) Piston pin spacer
- (H) Crankcase
- (J) Oil seal
- (K) Dowel pin
- (L) Ball bearing
- (M) Crankshaft assembly
- (N) Piston pin
- (P) Crankcase gasket

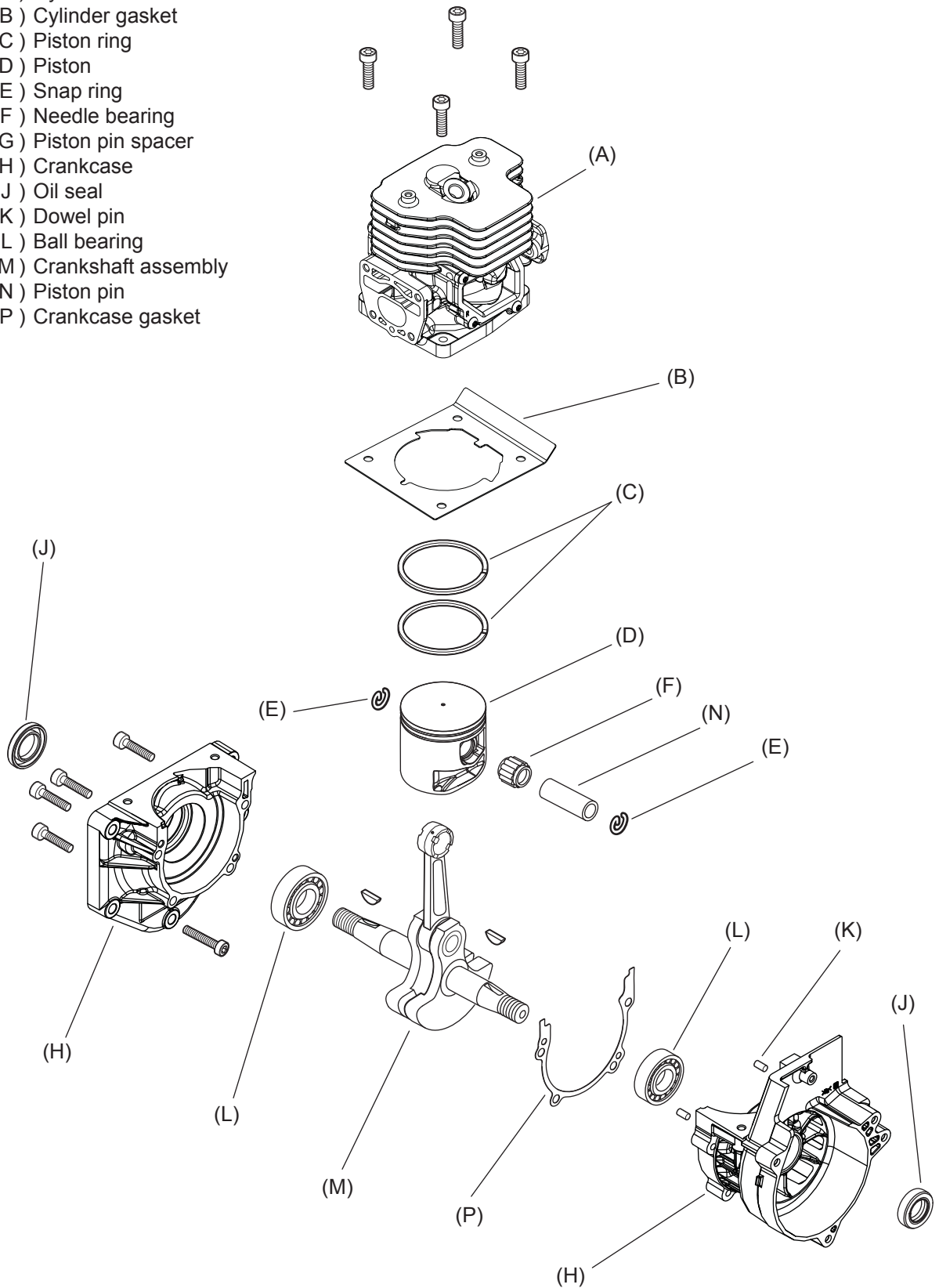

7-1 Testing cylinder compression

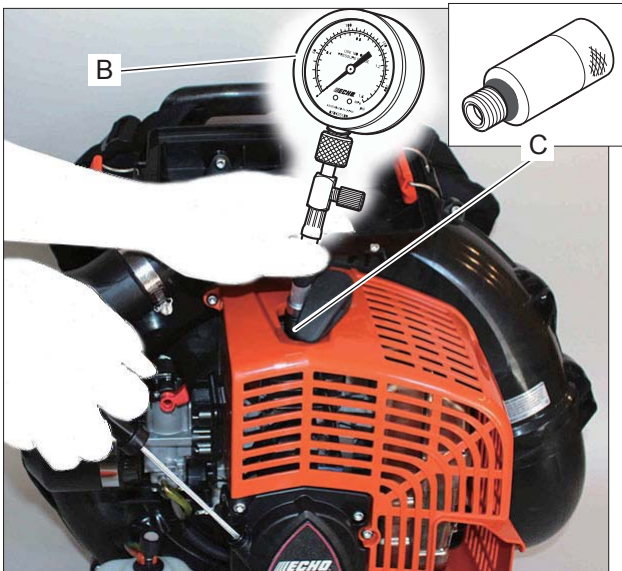
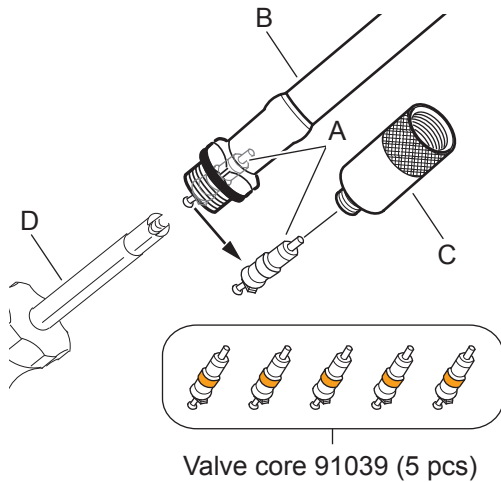

NOTE: Test cylinder compression when engine is cold.

1. Move ignition switch to STOP position.
2. Open cap cover and remove spark plug (Refer to 3-2 Testing spark).
3. Remove valve core (A) from compression gauge 91037 (B) and insert valve core (A) to adapter P021-051690 (C) with valve core driver (D).
4. Connect adapter (C) and compression gauge (B).
5. Install compression gauge 91037 (B) with adapter P021-051690 (C) in spark plug hole and tighten by hand. Pull starter several times to stabilize reading on compression gauge.

6. If pressure is lower than approx. 75% of standard compression pressure (Refer to "1-2 Technical data"), inspect cylinder bore, piston and piston ring for wear or damage.

7. If pressure is more than approx. 125% of standard compression pressure, inspect cylinder combustion chamber and exhaust port, piston crown, and muffler for carbon deposits.

NOTE: Compression pressure varies with volume of compression gauge tip occupying cylinder combustion chamber. When you use other than the tool 91037 (B) and adapter P021-051690 (C), it is recommended to measure and note compression pressure of brand-new engines as standard pressure in advance.

7-2 Cleaning cooling air passages

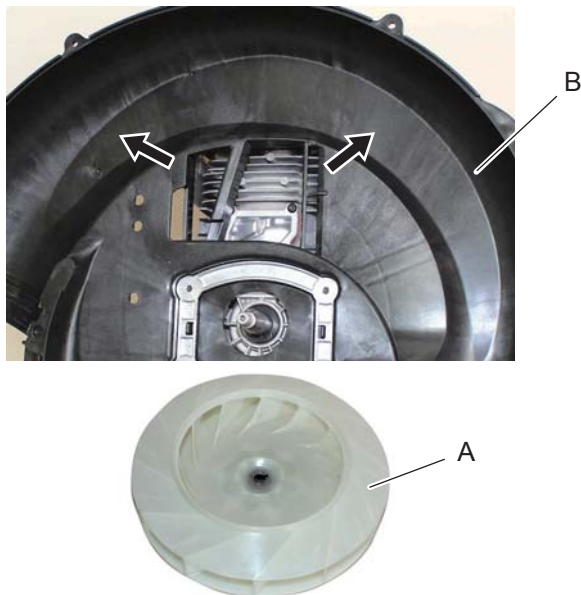

NOTE: To maintain proper engine operating temperatures, cooling air must pass freely through the cylinder fin area. This flow of air carries combustion heat away from the engine.

1. Most of engine cooling come from blower fan (A). Cooling comes through a large duct in the fan housing. Clean accumulated debris from fan case (B) with brush or compressed air as required.

WARNING  **DANGER**

Always wear eye protection when using compressed air for cleaning. Otherwise, eye damage can occur from flying particles.

7-2 Cleaning cooling air passages (continued)



2. Remove engine cover if cylinder fins (C) are hard to clean. Clean the clearance of cylinder fins using wooden stick, plastic stick or compressed air.

NOTE: To prevent debris from entering cylinder, reinstall spark plug, carburetor, and air filter before cleaning cylinder fins.

7-3 Inspecting muffler and exhaust port

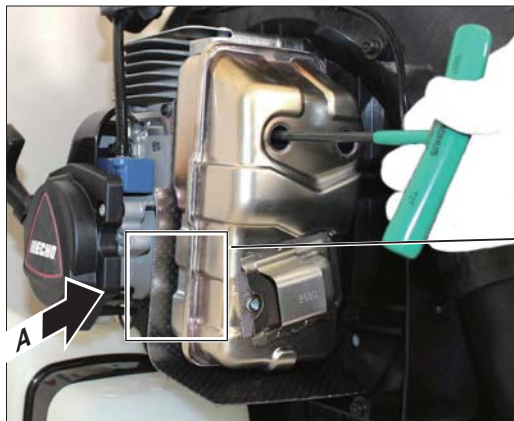

1. Loosen three bolts and remove muffler.

NOTE: One (A) of bolts is on back of muffler.

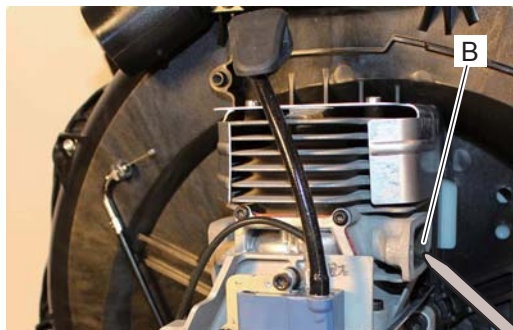
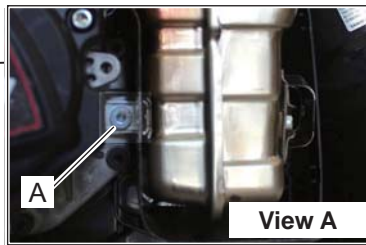

2. Inspect cylinder exhaust port (B) and clean the port (B) using wooden or plastic stick if carbon is found.

NOTE: When cleaning exhaust port, always position piston at Top Dead Center (TDC) to prevent carbon from entering cylinder. Do not use metal tool, and be careful not to scratch piston or cylinder.

NOTE: Replace muffler gasket with new one when removing muffler.

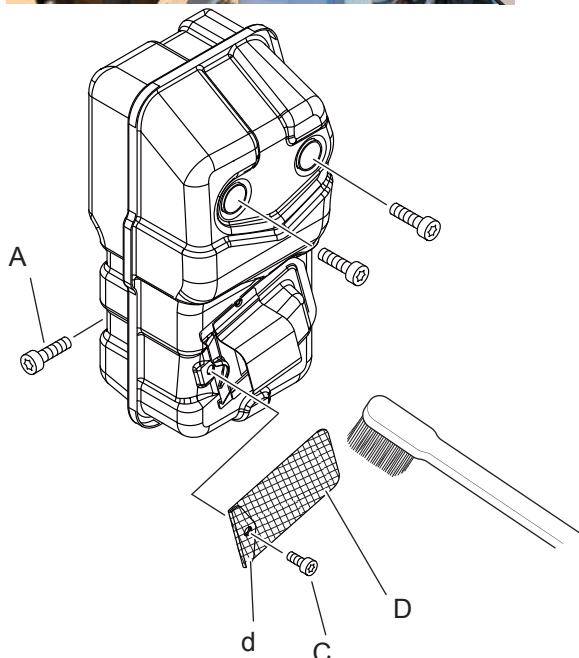

3. Remove bolt (C) and spark arrestor screen (D) from muffler.

4. Remove carbon deposits from spark arrestor screen (D). If screen has heavy deposits, replace with new one.

5. Reassemble spark arrestor screen (D) and tighten bolt (C).

NOTE: Bent edge (d) of spark arrestor screen (D) is outside.

6. Reinstall muffler with new muffler gasket.

7-4 Testing crankcase and cylinder sealings

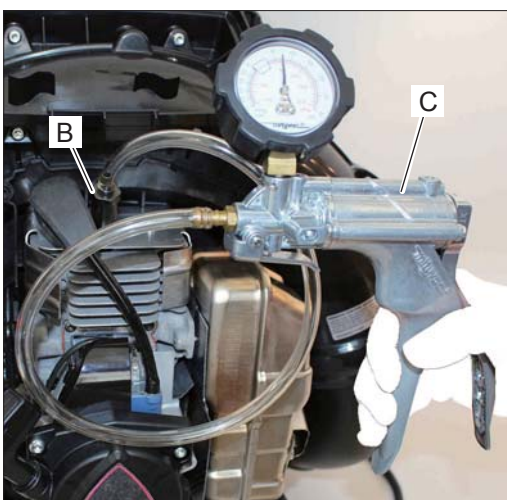
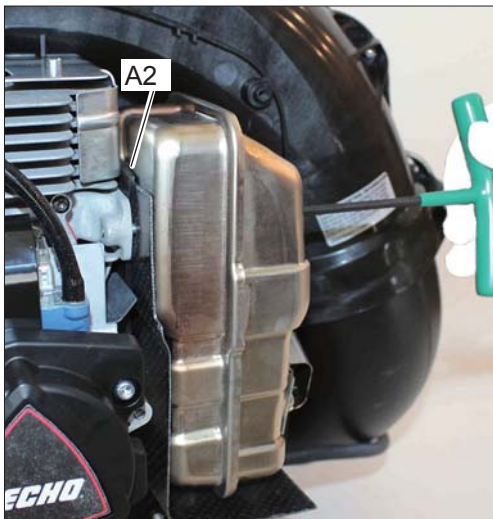
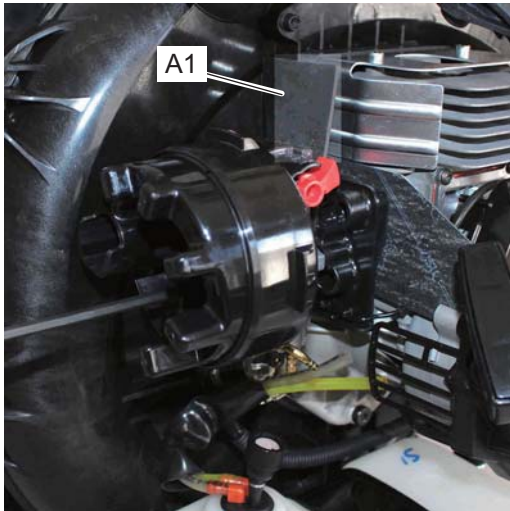

1. Loosen two bolts.

2. To seal intake port and crankcase pulse passage, install pressure rubber plug 91041 (A1) between carburetor and carburetor insulator.

3. Loosen muffler bolts. And to seal exhaust port, insert pressure rubber plug 91041 (A2) between muffler gasket and exhaust port of muffler as shown. Then retighten muffler bolts.

4. Remove spark plug and install pressure connector A131-000160 (B) to spark plug hole.

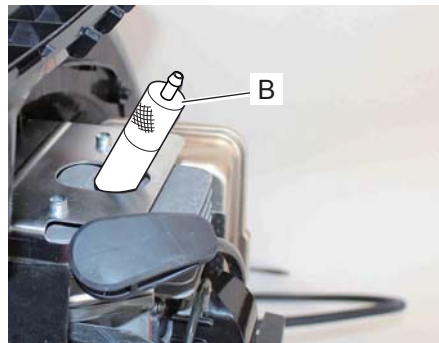

5. Connect pressure/vacuum tester 91149 (C) to pressure connector (B).

6. Apply negative pressure approx. 30 kPa (0.3 kgf/cm²) (4.4 psi) by pressure tester and leave for 30 seconds.

7. If the reading drops, leakage may occur from oil seal. Inspect oil seal for damage or wear.

8. Then, apply pressure approx. 50 kPa (0.5 kgf/cm²) (7.3 psi) by pressure tester and leave for 30 seconds.

9. If the reading drops, leakage may occur.

10. Leakage may occur from crankcase seam or oil seal. Use soapy water to locate leakage.

7-4 Testing crankcase and cylinder sealings (continued)

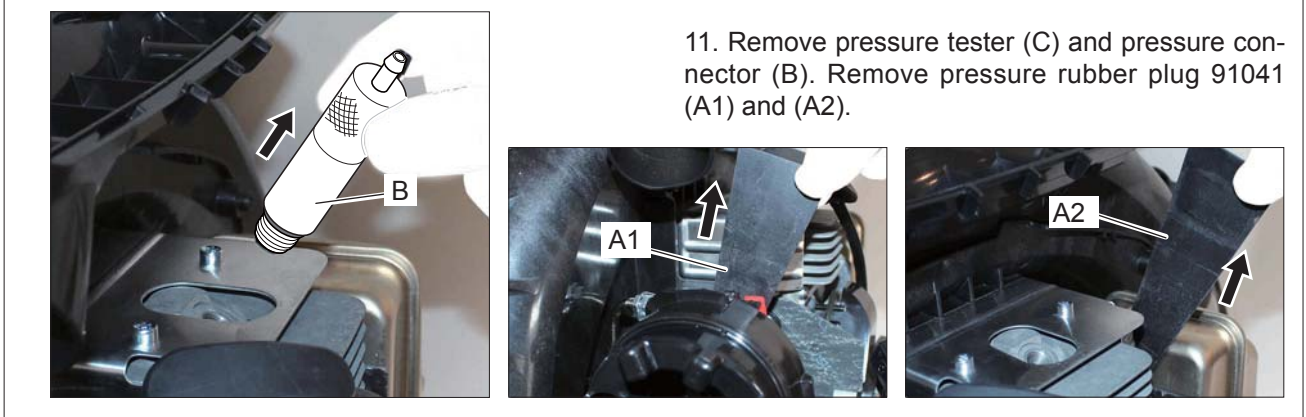

7-5 Replacing oil seal

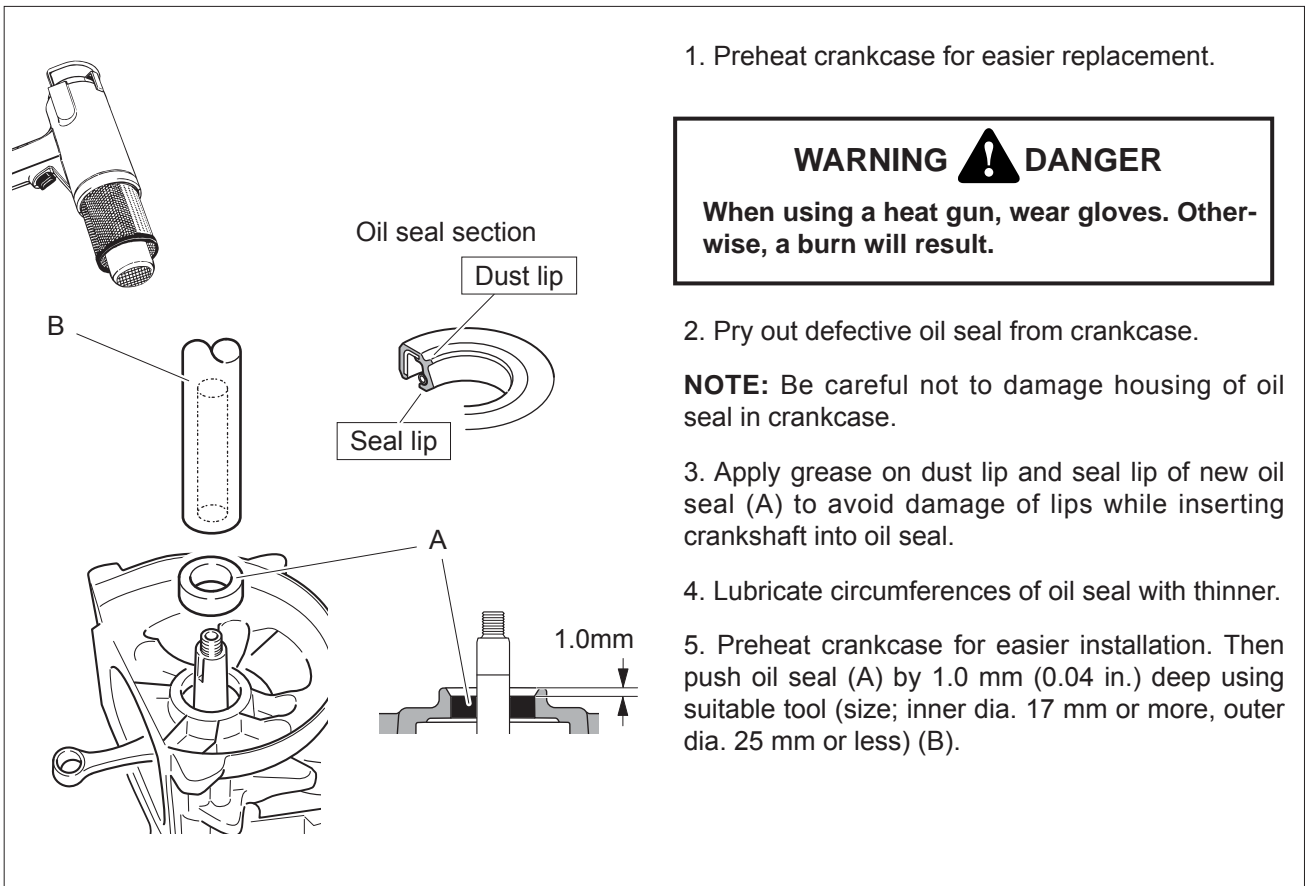

7-6 Inspecting cylinder

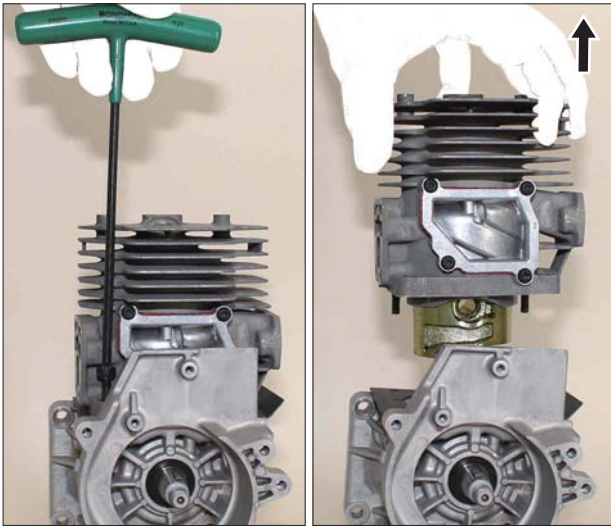
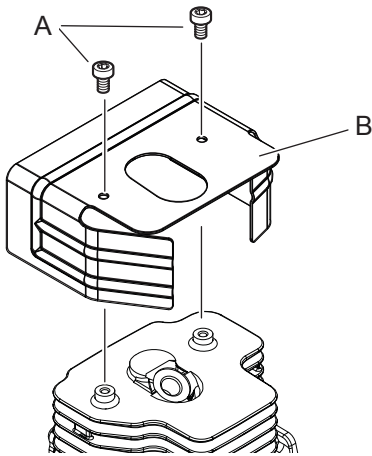

1. Loosen two bolts (A) and remove cylinder cover (B).

2. Loosen four bolts to remove cylinder from engine.

NOTE: When removing cylinder solely for the purpose of inspecting cylinder, leave ignition module, and intake insulator to avoid extra work.

NOTE: Gently tap cylinder with plastic mallet at carburetor and/or muffler sides of the cylinder head if it is difficult to remove.

3. Inspect cylinder combustion chamber and clean with a plastic or wooden scraper if carbon is found.

NOTE: Do not use metal tools, or damage to cylinder wall may result.

4. Inspect cylinder wall and replace with new one if plating is worn, peeled away, scored or exposing cylinder base metal.

7-7 Inspecting piston and piston ring

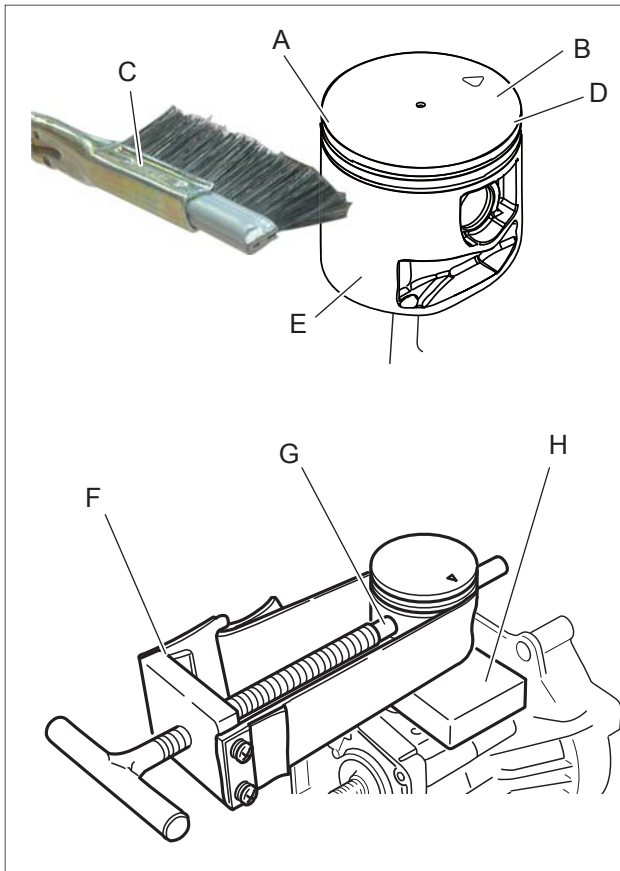

1. Inspect piston ring (A) and replace it if broken, scored, or exceeded service limits (Refer to "1-5 Service limits").

2. Inspect piston crown (B). Clean with fine sand paper, oil stone, and soft cleaning brush (C) if carbon is found.

3. Inspect top land (D), ring groove and skirt (E). Clean them with soft cleaning brush (C), if carbon is found.

NOTE: Do not use square end of broken piston ring when cleaning piston ring groove, otherwise piston ring groove might be damaged.

4. Remove snap rings from both sides of piston pin.

5. Push piston pin out from piston.

NOTE: If piston pin is tight, use piston pin tool 897702-30131 (F) with adapter (G) stamped "8" on an end and piston holder 897719-02830 (H).

6. Inspect needle bearing and washers, and replace if wear or discoloration is noted.

7-8 Disassembling crankcase

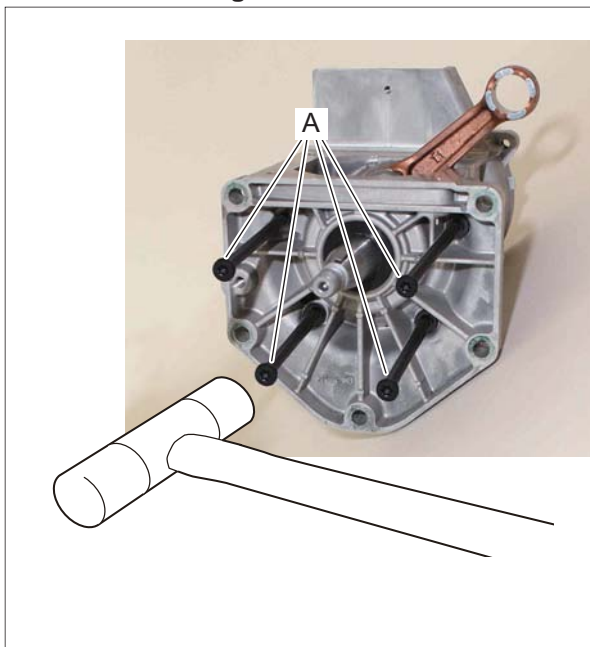

1. Remove cylinder, gasket and piston.

2. Remove woodruff key from crankshaft flywheel end.

3. Remove four crankcase bolts.

4. Screw M5 bolts (A) of length 65-75 mm (2.5 -3.0 in) to crankcase as shown.

5. Hold crankcase and alternately tap four bolts (A) using plastic mallet to separate crankcase halves.

6. Clean inside of crankcase halves if dirty. Replace as a set if damaged.

7. Inspect crankshaft for roughness (crankshaft runout), discoloration, or other damage. Replace it with new one as required.

7-9 Replacing ball bearing

1K327

(Fan side) (Starter side)

1. Check oil seal(s) and replace if defective.
2. Check ball bearing(s) for smooth rotation. If not, remove ball bearing(s) using bearing wedge (A) 897701-02830 or a suitable bearing puller.
3. **Fan side:** Install new ball bearing using bearing/seal tool 897726-21430 (B) (inner dia. 15 mm, outer dia. 24.5 mm) to the bottom.
4. **Starter side:** Install new ball bearing using bearing/seal tool 897726-16431 (C) (inner dia. 17 mm, outer dia. 35 mm) to the bottom.

NOTE: Preheat ball bearing using a heating gun, heat lamp, or a suitable heater for easier installation.

WARNING  **DANGER**

When using a heat gun, wear gloves. Otherwise, a burn will result.

7-10 Removing ball bearing in crankcase

(Fan side) (Starter side)

When holding on assembling ball bearing in crankcase after disassembling crankcase, remove ball bearing as follows.

1. Check main ball bearing for smooth rotation, after disassembling crankshaft. If rough, replace it (them) with new one.
2. Pry oil seal from crankcase.
3. Remove main ball bearing from crankcase half using bearing tool 897701-14732 as follows.
4. **Fan side:** Set boss (A) and shaft (B) with adapter (C) (inner dia. 12 mm, outer dia. 19 mm) as shown.
5. **Starter side:** Set boss (A) and shaft (B) as shown.
6. Tighten shaft (B) with wrench to remove ball bearing.
7. Install new ball bearing to crankshaft (Refer to "7-9 Replacing ball bearing").

7-11 Assembling crankshaft and crankcase

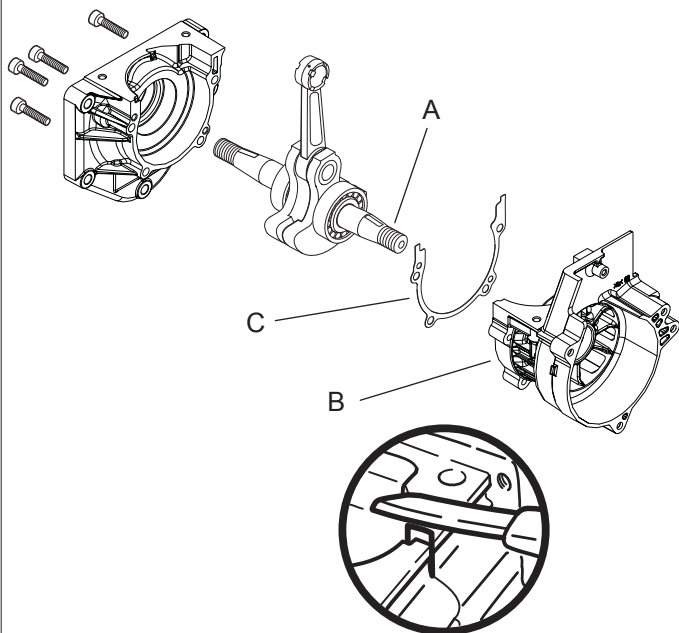

1. Clean mating surface of each crankcase half.
2. Heat ball bearing for easier installation. Then insert crankshaft starter end (A) into starter side crankcase half (B) until properly seated.

WARNING  **DANGER**

When using a heat gun, wear gloves. Otherwise, a burn will result.

3. Place new crankcase gasket (C) on starter side crankcase half (B).
4. Reassemble both crankcase halves together ensuring that dowel pins on crankcase half are properly seated in holes of the opposite crankcase half.
5. Tighten four bolts to secure crankcase halves together and check crankshaft for smooth rotation.

NOTE: If crankshaft doesn't rotate smoothly, tap both ends of crankshaft with plastic mallet several times. And recheck crankshaft for smooth rotation.

6. Carefully remove excess portion of crankcase gasket (C) with sharp knife.

7-12 Installing piston

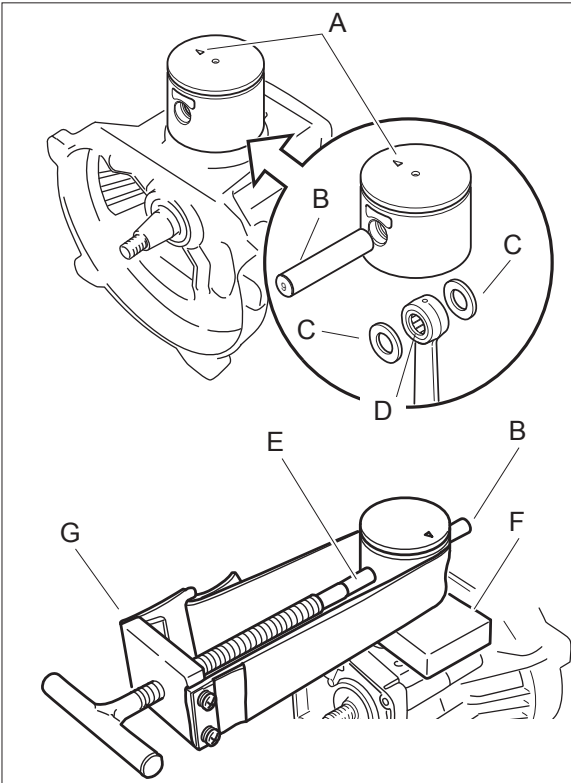

1. Place piston over the small end of connecting rod, so that the arrow mark (A) on piston points toward muffler.

2. Insert piston pin guide (B) stamped "9", through piston, washers (C) and needle bearing (D) in connecting rod as shown.

3. Insert piston pin (E) in piston pushing out piston pin guide (B) using piston pin tool 897702-30131 (G) and piston holder 897719-02830 (F).

4. Install new snap rings to the piston pin bore, and be sure that they are correctly seated in the grooves.

7-13 Installing piston ring and cylinder

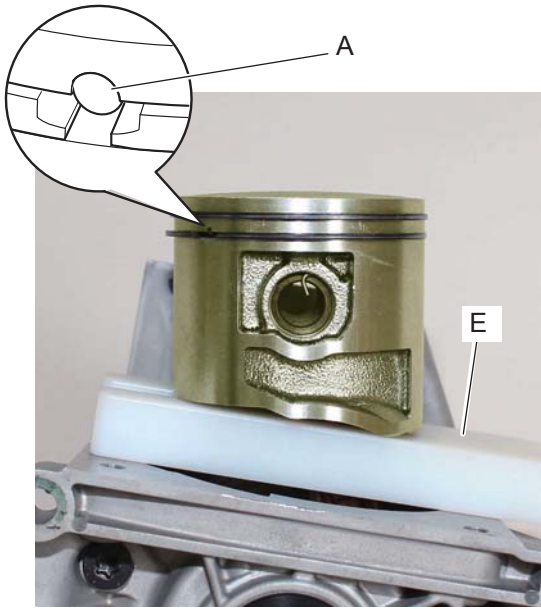

1. Install piston ring on piston ensuring that locating pin (A) is positioned between ring ends.

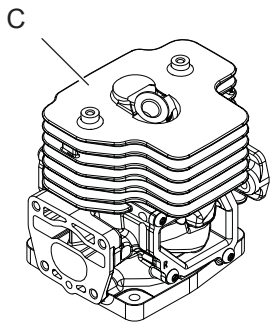

Assembled

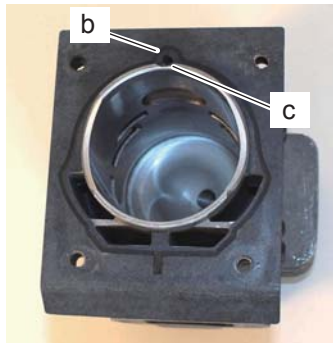

View A

2. Set new cylinder gasket (B) under cylinder (C). Position it so cylinder gasket pulse slot (b) and pulse hole (c), lines up with cylinder.

3. Apply oil to piston ring and cylinder internal wall.

4. Install cylinder over piston ensuring that exhaust side of cylinder is at arrow side (D) of piston.

NOTE: When installing piston, it is convenient to use piston holder 897719-02830 (E) for stabilizing piston.

NOTE: Do not twist cylinder while installing, otherwise, piston ring and/or cylinder wall may be damaged.

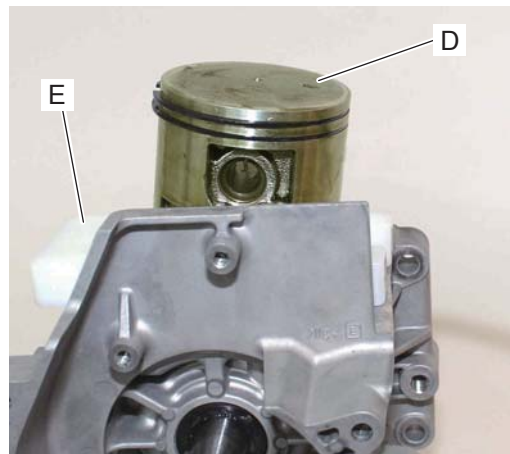
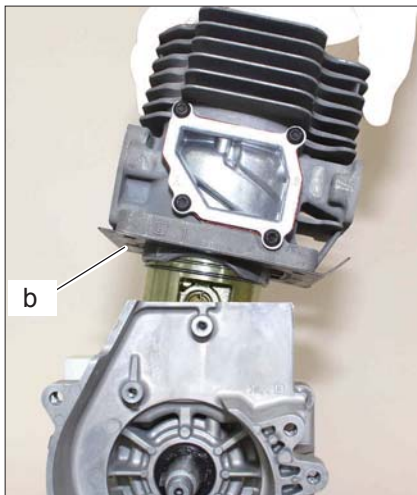
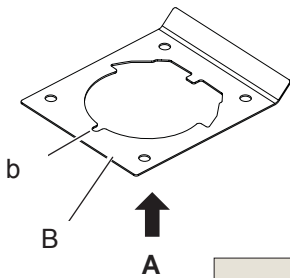

7-13 Installing piston ring and cylinder (continued)

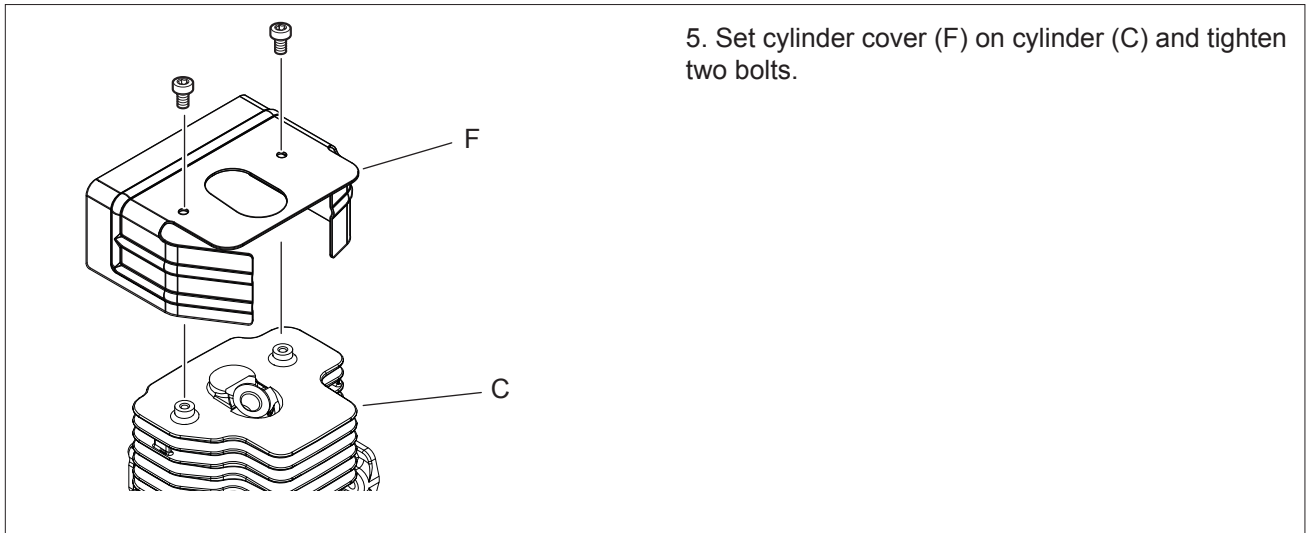

7-14 Assembling engine assembly and other parts

Assemble engine assembly and other parts, referring to the following instructions.

1. Assembling flywheel and woodruff key: "4-11 Replacing flywheel and key"
2. Assembling engine assembly and ignition switch: "3-6 Replacing ignition switch".
3. Assembling fuel tank and lines: "4-3 Inspecting fuel tank and line", "4-4 Replacing fuel lines and grommet"
4. Assembling fan and fan case: "6-3 Disassembling and assembling fan".
5. Assembling starter pawl: "2-5 Replacing starter pawl".

8 MAINTENANCE GUIDE

8-1 Troubleshooting guide

TROUBLE	
Engine does not crank.	01
Engine does not start.	02
Fuel leaks.	03
Idling is not stable.	04
Acceleration is poor.	05
Engine stalls at high speed.	06
Engine lacks power.	07
Engine overheats.	08
Engine misfires.	09
Engine/others are extremely noisy.	10
Fuel consumption is excessive.	11
Vibration is excessive.	12
Engine does not stop.	13

INSPECTING	REFERENCES	Inspecting <input type="radio"/> first.												
		13	12	11	10	09	08	07	06	05	04	03	02	01
Starter system		13	12	11	10	09	08	07	06	05	04	03	02	01
Rewind spring	2-3													<input type="radio"/>
Starter pawl / spring	2-5													<input checked="" type="radio"/>
Ignition system		13	12	11	10	09	08	07	06	05	04	03	02	01
Sparks	3-2					<input checked="" type="radio"/>			<input type="radio"/>	<input type="radio"/>	<input type="radio"/>		<input checked="" type="radio"/>	
Spark plug	3-3					<input type="radio"/>	<input type="radio"/>		<input type="radio"/>	<input type="radio"/>	<input type="radio"/>		<input type="radio"/>	
Spark plug cap / coil	3-4					<input type="radio"/>							<input type="radio"/>	
Ignition switch	3-6	<input checked="" type="radio"/>				<input type="radio"/>							<input type="radio"/>	
Ignition coil	3-8					<input type="radio"/>			<input type="radio"/>	<input type="radio"/>	<input type="radio"/>		<input type="radio"/>	
Pole shoe air gaps	3-9					<input type="radio"/>	<input type="radio"/>				<input type="radio"/>		<input type="radio"/>	<input type="radio"/>
Flywheel	3-10		<input type="radio"/>			<input type="radio"/>					<input type="radio"/>		<input type="radio"/>	
Flywheel key	3-11					<input type="radio"/>	<input type="radio"/>	<input type="radio"/>		<input type="radio"/>	<input type="radio"/>		<input type="radio"/>	

(Continued)

8-1 Troubleshooting guide (continued)

INSPECTING	REFERENCES	Inspecting ☉ first.												
		13	12	11	10	09	08	07	06	05	04	03	02	01
Fuel system / Carburetor		13	12	11	10	09	08	07	06	05	04	03	02	01
Air filter	4-1			○				○	○	○	○			
Fuel cap / strainer	4-2						○	○	○	○	○	☉		
Fuel tank / vent / line	4-3 to 4-5						○	○	○	○	○	☉	○	
Carburetor adjustment	4-13			☉			○	☉	☉	☉	☉		○	
Carburetor leakage	4-7			○				○	○	○	○	○	○	
Crankcase pulse passage	4-8						○		○	○	○			
Carburetor metering lever	4-9			○			○	○	○	○	○	○	○	
Carburetor inlet valve	4-10			○					○	○	○	○	○	
Carburetor diaphragm	4-11			○				○	○	○	○	○	○	
Check main jet	4-12						○	○		○				
Throttle lever	3-6							○		○	○			
Fuel	1-1						○	○		○	○		○	
Oil	1-1						○							
Engine		13	12	11	10	09	08	07	06	05	04	03	02	01
Cylinder compression	1-2, 7-1				○		○	○		○	○		○	
Cooling air passage	7-2						☉	○						
Muffler / Exhaust port	7-3				☉			○	○	○				
Crankcase / cylinder sealings	7-4						○	○	○	○	○		○	
Cylinder	7-6				○		○	○			○		○	○
Piston / Piston ring	7-7				○		○	○			○		○	○
Crankshaft	7-11		○			○					○		○	○
Oil seal / Ball bearing	7-5, 7-9, 7-10							○			○		○	○
Blower		13	12	11	10	09	08	07	06	05	04	03	02	01
Fan	6-3		☉					○						○
Fan case	6-1, 6-4							○						○

8-2 Disassembly chart

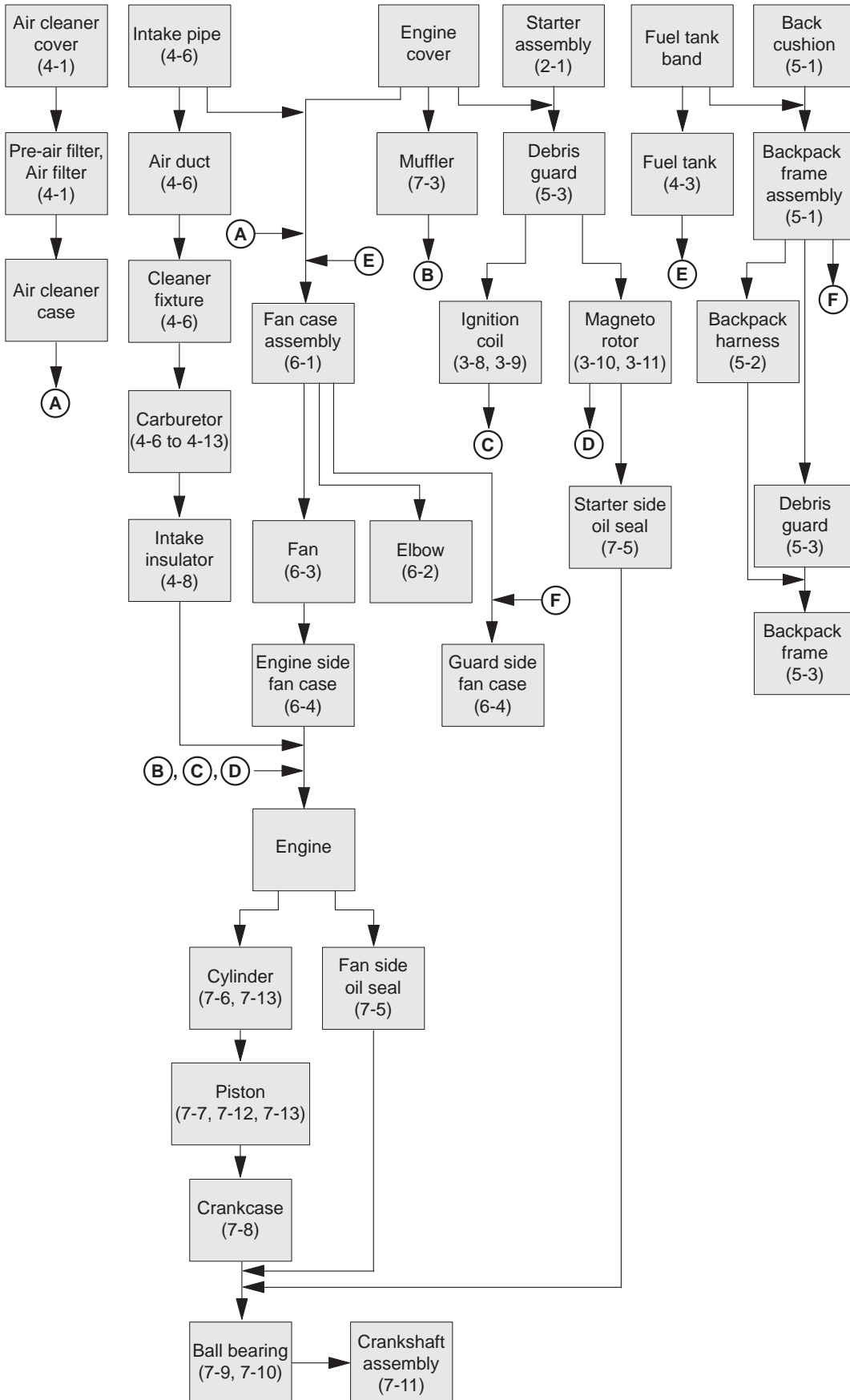

8-3 Service intervals

Inspecting point	Service	Reference	Intervals		
			Daily or Before use	3 months or 100 hours	6 months or 300 hours
Screws and bolts *	Retighten / Replace		○		
Air filter	Inspect / Clean	4-1	○		
Choke system	Inspect / Clean		○		
Carburetor	Inspect / Repair	4-6 to 4-13			○
Fuel leaks	Inspect / Repair	4-2 to 4-5	○**		
Fuel line and grommet	Inspect / Repair	4-4	○		
Fuel strainer	Clean / Replace	4-2		○	
Fuel tank	Clean inside	4-3		○	
Spark plug	Clean / Regap	3-3		○	
	Inspect / Replace	3-2, 3-3			○
Muffler Spark Arrestor	Inspect / Clean / Replace	7-3		○	
Muffler and exhaust port	Inspect / Clean	7-3	○		
Leads and connections	Inspect / Repair	3-5, 3-6		○	
Starter system	Inspect / Repair	2-1 to 2-5	○		

Daily: Inspecting in every services.

IMPORTANT: Service intervals shown above are maximum. Actual use and your experience will determine the frequency of required maintenance.

* Retighten the following screws and bolts after first 1 week use, and every 3 months.

Starter assembly bolts (3 pcs.)

Muffler bolts (3 pcs.)

** Inspect after every refuel.

ECHO®

shindaiwa®

YAMABIKO

Published by
YAMABIKO Corp.
Tokyo Japan

2009